

TYRE CHANGER

INSTRUCTION & MAINTENANCE MANUAL

We follow the way that wheel moving!



Read this entire manual carefully and completely before installation or operation of the tire changer

TYRE CHANGER INSTRUCTION MANUAL

INDEX	PAGE
1. Introduction:.....	2
2. Safety Warnings:	2
3. Technical data	3
4. Transport:.....	3
5. Unpacking & Inspection:	3
6. Workplace requirements:	3
7. Position and installation:.....	3
8. Electricity and Pneumatic connections:	4
9. Adjusting operation:.....	4
9.1. Breaking the tyre bead:	5
9.2. Demounting the tyre :	5
9.3. Mounting the tyre :.....	5
10. Help Arm 036.....	6
10.1 Technical Data.....	6
10.2. Safety Regulations	6
10.3. Installation	6
10.3.1. Transport	6
10.3.2. Unpacking	6
10.3.3. Workplace Requirement.....	6
10.3.4.Assembly.....	7
10.4. Functional Parts	7
10.5. Trial operation.....	7
10.6. Operations	7
10.6.1. Fixing The Tire.....	7
10.6.2. Demounting The Tire	8
10.6.3. Mounting the tire.....	8
11. Inflating the tire :.....	9
12. Moving machine:	9
13. Maintenance:.....	9
14. Trouble shooting table:	11
15. Exploded drawing:.....	12
16. Circuit diagram:	23
17. Pneumatic drawing:	23

Tyre Changer

Warning

This instruction manual is important for the machine, please read carefully before installation and use; also it is important for safe use and machine maintenance of machine. Please keep this manual properly in order to further maintenance of the machine.

1. Introduction:

Application Range: The automatic tyre changer is especially designed for demounting / mounting tyres from wheel rims.

Caution: Please use the machine only for purpose for which it is designed, don't use it for other purposes.

Manufacturer shall not be liable for any damage or injury caused by failure to comply with these regulations.

Safety regulation: Use of this machine is especially reserved to trained and qualified professional persons, those who already read the introduction manual carefully, or someone have the experience for operating similar machinery. Any changes and beyond the scope of use on this machine without manufacturer's permission or do not according to the manual, may cause the malfunction and damage to machine, manufacturer can cancel warranty coverage for above. If some parts are damaged due to some reason, please replace them according to the spare parts list. (Attention: warranty is one year after manufactures' delivery date; warranty excludes the easy-broken parts).

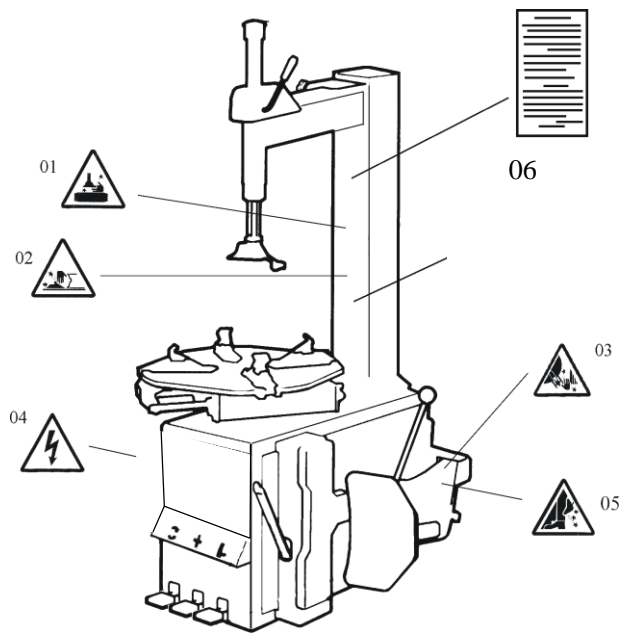

2. Safety Warnings:

- 01 Don't put hands under the Mounting head/demounting head during operation;
- 02 Don't put hands between the jaws during operation;
- 03 Don't put hands in the tyre bead when demounting the tyre;
- 04 Make sure and to check the system is equipped with a good grounding circuit;
- 05 Don't put feet between the Bead Breaker shovel and the body during operation;
- 06 Warning instruction

Security warning labels

Caution:

When the security warning labels are defaced or off, please recovery them in time!

Do not allow to operate when the security warning labels are missed or imperfect.

Do not allow to set any objects to obscure the security warning labels.

Clients can self-set the warning labels (as right picture show) at any necessary positions.



3. Technical data

External locking rim dimensions	12~23 "
Internal locking rim dimensions	14~26 "
Max. Wheel diameter	1143mm (45 ")
Max. Wheel width	406mm(16 ")
Working Pressure	8-10bar
Power supply	110V (1ph)/ 220V (1ph)/ 380V (3ph)
Optional Motor power	0.75/0.55/1.1 kw
Max. Rotating Torque (Turntable)	1078 Nm
Overall Dimension	1130*900*1030mm
Noise Level	<75dB

Remark:

Rim dimensions defined at above table are based on the iron wheel rims. Aluminum rims are thicker than the iron wheel rims, so here above rim dimensions are just for the reference.

Here above machine versions can be equipped with Rapid Tire Inflation Device (client optional device), IT-suffix version, accessory details can be found at the IT-suffix version diagram.

4. Transport:

When transporting, the machine should be with original package and placed according to the mark on the package. For the already packaged machine should be handled with a corresponding tonnage forklift for loading and unloading. The location to insert the fork feet shown as **Fig 1**

5. Unpacking & Inspection:

Pull out the nail which is nailed on the plate with tip jaw; unpack the carton and plastic cover. Check and make sure all parts shown on the spare parts list are included. If any parts are missing or broken, please do not use the machine and contact the manufacturer or dealer ASAP.

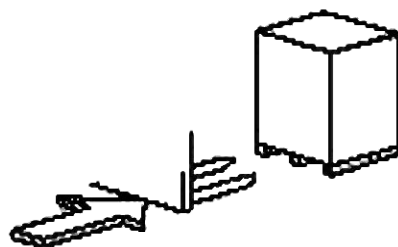

Fig 1

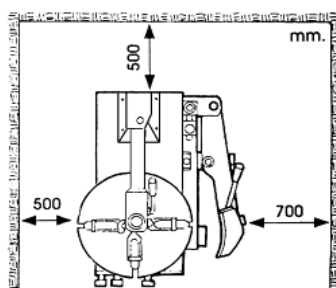

Fig 2

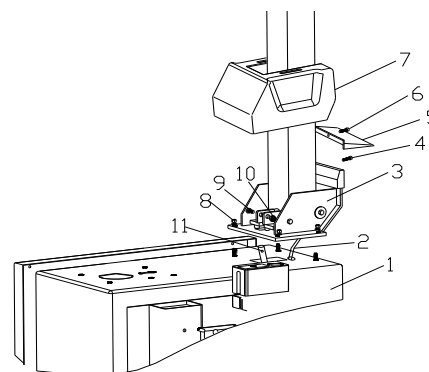

Fig 3

6. Workplace requirements:

Choose workplace in compliance with safety regulations. Connect power supply and air source according to manual and workplace must have good air condition; in order to make the machine run well, its workplace requires at least clear space from each wall shown as **Fig 2**. If installing it outdoor, it must be protected by roof against rain and sunshine.

Warning: the machine with motor must not be operated in explosive atmosphere.

7. Position and installation:

7.1 Install the column (accessories details refer to the exploded drawing)

- 1) Tools preparation
- 2) Place the tilting seat (3, Fig 3) on the body (1, Fig 3) with 4 bolts (M12), push air hose (2, Fig 3) through the hole of the column. Tighten 4 self-locking nut(8, Fig 3).
- 3) Insert screw (9, Fig 3) into the holes of both column and tilting cylinder shaft (11, Fig 3), tighten it with self-locking nut (10, Fig 3).
- 4) Unscrew the two bolts on the left cover and remove the cover, connect air hose (2, Fig 3) previously mentioned to the side holes which control the tilting 5-way valve. Fix the left cover.
- 5) Fix the plastic cover (7, Fig 3) with two bolts (4, Fig 3).
- 6) Mount the plastic back cover (5, Fig 3) on the column with screw (6, Fig 3).

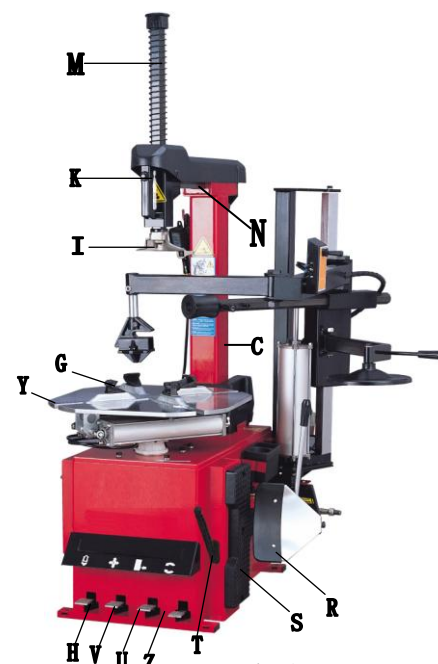

Fig 4

8. Electricity and Pneumatic connections:

Warning: Before installation and connection, check to be sure that the electricity power supply corresponds to the machine technical data. All the installation of electric and pneumatic devices must be operated by a professional electrician.

Connect the compressed air connector which is on the machine right side with compressed air system. The electric grid that the machine connects to must have fuses protection device and good outer cover grounding protection. Install the leakage automatic air switch on the main power supply, leakage current is set at 30A

Caution: No power plug for this machine, the user should self-connect one power plug no less than 16A as well as in line with the machine voltage. Or directly connect with the power supply according to the above requirements.

9. Adjusting operation:



Tilting pedal (H)



Turntable Rotation pedal (Z)

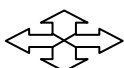

Jaws open and close pedal(V)



Bead Breaker pedal(U)

Please note: below operation refer to Fig 4

Tread the Turntable Rotation Pedal (Z), Turntable (Y) clockwise rotation;

Lift up the Turntable Rotation Pedal (Z), Turntable (Y) counterclockwise rotation.

Tread Bead Breaker Pedal (U), Bead Breaker shovel (R) compress; release Bead Breaker Pedal (U), Bead Breaker shovel (R) back to original position.

Tread totally down Jaws open and close Pedal (V), four clamps (G) on the turntable open; Tread again, four clamps (G) close. When the pedal is in the middle position, the four clamps stop moving.

Depress pneumatic locking button (K) to lock the Slide arm (N) and Vertical arm (M).

Tread the Bead Breaker pedal (H), the tilting column (C) backwards down; depress again, the tilting column return.

Tyre changer operation is consisted of three parts:

- 1) Demounting the tyre bead
- 2) Demounting the tyre
- 3) Mounting the tyre

Caution: Before any operations, don't wear loose clothing and wear protective hat, gloves, and skid-proof shoes. Ensure to exhaust the air in the tyre completely, and remove all the wheel weights from the rim.

9.1. Breaking the tyre bead:

Ensure to exhaust the air in the tyre completely, place the tyre against the rubber buffer (S). Bring the shovel (F) against the bead about 10mm from the edge of the rim shown as **Fig 5**. Depress Bead breaker Pedal (U) to push paddle into tyre. Repeat the above operations on different positions around the tyre and both sides of tyre until tyre bead is released completely.

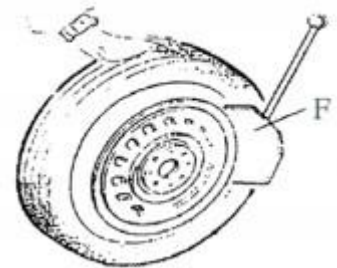

Fig 5

9.2. Demounting the tyre :

Ensure to remove all the weights on the wheel rim and to exhaust the air in the tyre completely before this operation. Apply lubricating grease (or similar lubricant) around the tyre bead. Without the lubricant may lead to badly wear and tear on tyre.

Clamp the wheel methods shown as below regarded to the ruled dimension:

a- to clamp the wheel from outside:

Depress the Jaws open and close Pedal (V) halfway down to middle, positioning for the four clamps (G) by reference scale on the Turntable (Y); put the tyre on turntable, hold the rim, and depress the Jaws open and close Pedal (V) until the wheel is secured by the jaws.

b- to clamp the wheel from inside:

Positioning for the four clamps (G) and let them all closed. Put the tyre on the turntable and depress the Jaws open and close Pedal (V) to open the clamps thereby lock the wheel in place.

Caution: Check to make sure the wheel firmly secured by the four clamps before next step.

Lower the Vertical Arm (M) until the Mounting head/demounting head (I) rests next to the edge of the rim, flip pneumatic locking button (K) to lock the Vertical Arm (M) and Horizontal arm in position, and control the distance from Mounting head/demounting head to the edge of wheel rim about 2-3 mm. Insert the Lifting Lever (T) between the tyre bead and the front section of the mounting head/demounting head (I), and move the tyre above the mounting head/demounting head as shown as **Fig 6**.

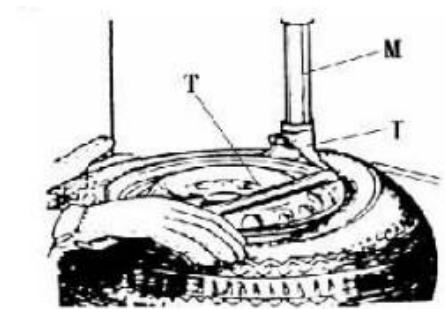

Fig 6

Caution: Chains, bracelets, loose clothes and anything else close to the rotating parts will bring danger to the operator.

With the Lifting Lever held in position, depress the Turntable Rotation Pedal (Z), rotate the Turntable (Y) in a clockwise direction until the tyre is completely separated from the wheel rim.

For the other side tyre demounting, keep using the lifting lever to lift the tyre, make the other side tyre separated from the wheel rim. Depress the Tilting pedal (H), the column backward down, take out the tyre.

9.3. Mounting the tyre :

Caution: Check to make sure that the tyre and the wheel rim are of same size before mounting the tyre.

To avoid any damage on type, lubricate the tyre bead and the wheel rim with the lubrication recommended by manufacturer. Put on the tyre and check the situation.

Caution: When clamp the wheel rim, don't put your hands on the wheel rim to avoid injury during this operation.

Lock the Hexagonal Vertical Mounting Arm, put the tyre on the rim, let the Rocker Arm back to place as demounting the tyre.

And let one side of tyre down bead above the rear section of the Mounting head/demounting head, the other side under the front section of the Mounting head/demounting head. Suppress the tyre with hands or help arm, and then spin the turntable for mounting the tyre down bead.

Repeat the above operation for mounting the tyre up bead. (Fig 7)

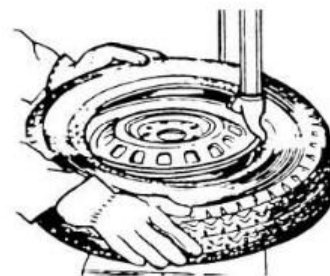

Fig 7

10. Help Arm 036

The help arm 036 is an auxiliary device for tire changer, it is used to help to demount and mount tires.

Before any operation of this machine, the operator is requested to read the manual carefully. Do not attempt any operations that are not stated in it. Manufacturer will not be responsible for any injury or damage caused by improper operation. Please keep the manual handy for consulting.

10.1 Technical Data

Work Pressure	8~10 bar
Weight	80kg
Package dimension	1230*450*350mm
Noise Level	LpA<75dB



10.2. Safety Regulations

This device is especially reserved to trained professional personnel or somebody who has experiences on mechanical operation and read this manual carefully. This device must be used together with our tire changers, we are not sure it can work with others. Manufacturer won't be responsible for any unauthorized modification

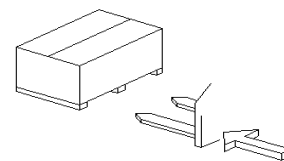

Fig 8

10.3. Installation

Notice!

The installation of this auxiliary device should be done by professional personnel. Before assembly, disconnect the device from power supply and air source.

10.3.1. Transport

Move the device with a forklift truck as illustrated in Fig 8.

10.3.2. Unpacking

When unpacking, check and make sure all parts shown on the packing list are included. If any parts are missing or broken, please call the manufacturer or the dealer asap. Please keep the package out of children's reach.

10.3.3. Workplace Requirement



图 9

Fig 9 shows the minimum distance (cm) from walls after assembly this auxiliary device. Please choose the right place to install it.

10.3.4.Assembly

- 1) Disconnect the tire changer from power supply and air source.
- 2) Install the column 3 with screw 1 and 2; install the support 5 of the auxiliary arm with screw 4; (Fig 10)
- 3) Install the help arm 6 with nut 7 and screw 9, then tighten 4、7、8、9 (Fig 10 、 Fig 11) ;
- 4) Install the Rotating arm (A)、 Hexagonal horizontal arm (B) and Tire lifting roller support (C) separately on the tire changer;(Fig 12)
- 5) Install the tire lifting roller (D)、 the switch (E)、 tire pressing head (F) and tire pressing roller(G) separately on the tire changer;(Fig 12)
- 6) Connect the air hose to the corresponding joint through the rear hole of the body.

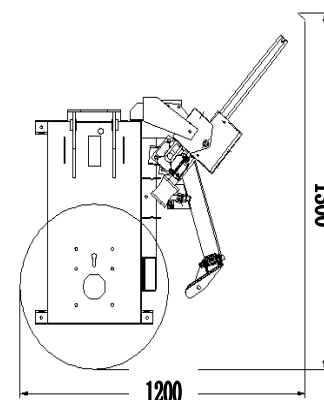
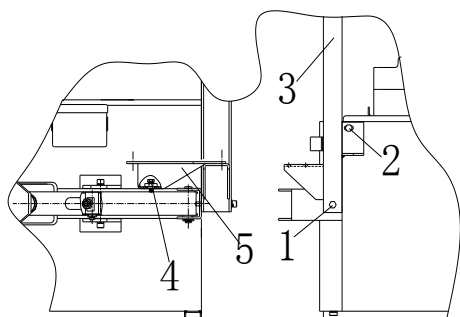

Fig 10

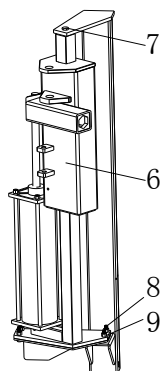

Fig 11

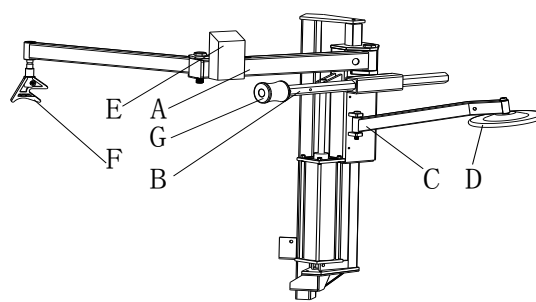

Fig 12

10.4. Functional Parts

Fig 12 shows functional parts to the 036 device:

- | | |
|--------------------------------|-----------------------------|
| A. Rotating arm connector | B. Hexagonal horizontal arm |
| C. Tire lifting roller support | D. Tire lifting roller |
| E. Raise-fall control assembly | |
| G. Tire pressing roller | |

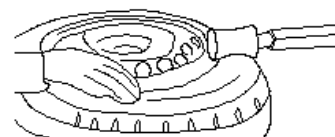

Fig 13

10.5. Trial operation

The 036 device must connect with the air compressor, and the air pressure from 8 bars to 10 bars is desirable.

10.6. Operations

Mounting and demounting big flat tire is difficult work. By the help of 036 help arm to mount/demount the tire from the tire bead will make the operation easier. It is a good helper for tire changer.

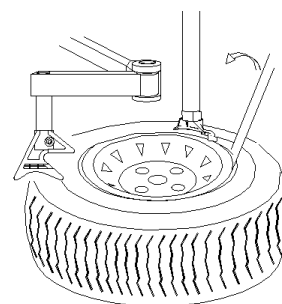

Fig 14

10.6.1. Fixing The Tire

Loosen the bead according to the manual. Clamp the tire from outside, tread the corresponding pedal to open the jaws;

Put the tire on the turntable; Tread the corresponding pedal to close the jaws until they near the rim.

10.6.2. Demounting The Tire

-1. Generally speaking, tire is very tight. Loosen the beads with the tire pressing head first (or using the bead breaker if it too tight to loosen).

Pull out the Hexagonal horizontal arm; let the tire pressing roller above the tire without collision.

Lower the tire pressing roller lower with the switch handle to press the tire. Tread the pedal to rotate the turntable. Loosen the bead during this procedure. **(Fig 13)**

Caution: Lubricate the tire pressing head (upper) and the bead before the operation.

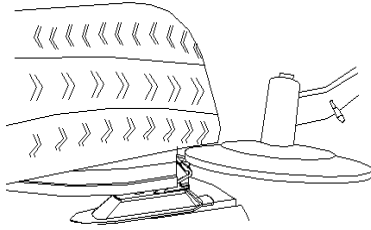

Fig 15

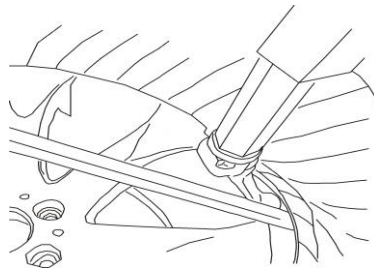

Fig 16

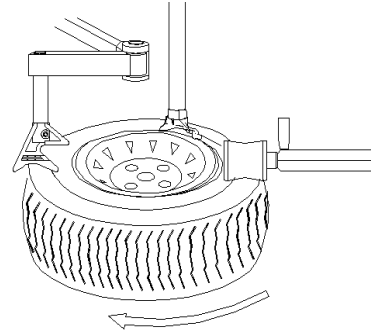

Fig 17

-2. Demounting the upper bead

a- Move the mounting head near the edge of the rim, rotate the tire pressing arm to move the tire pressing block above the tire, press the switch handle to depress the tire, and insert the lifting lever in the clearance between the tire and the rim, then hang the bead on the mounting head. **(Fig 14)**

b- Raise the auxiliary arm, rotate the tire pressing head to the opposite. Press the tire with the switch handle to create enough space.

c- Tread the power supply pedal to rotate the turntable. With the help of the tire pressing head, the upper tire bead is detached.

d- Raise the help arm to move the tire pressing block to its non-working position.

-3. Demounting the bottom bead

Turn the roller support and move it under the tire, but don't touch it with the rim.; **(Fig 15)** Tread the power supply pedal to rotate the turntable, meanwhile, lift help arm gradually to loosen tire and completely demount the bottom bead.

Caution: The roller support can't be used for all tires, some tires need following operation: Move the mounting head above the rim; Insert the lifting lever in the clearance between the bottom tire bead and the rim, have the tire hung on the mounting head(Fig 12); Tread the power supply pedal to rotate the turntable. With the help of the mounting head, the tire is detached completely.

10.6.3. Mounting the tire

Lubricate the tire bead and rotate the turntable, mount the bottom bead with the mounting head;
Pull the hex rod out, press the upper bead under the mounting head 5mm with the tire pressing roller, rotate the rotating arm and move the tire pressing block above the tire;
Don't touch with the rim in the operation, or it causes damage on the rim due to friction.

Tread the power supply pedal to rotate the turntable and the tire pressing block, lower the help arm to press the tire under the rim. Mount the tire with the mounting head. Please pay attention to the safety in the process of operation. **(Fig 17)**

11. Inflating the tire :

Importance: It is very dangerous during inflating operation, take carefully and comply with instruction. When inflating, it will turn to be extremely dangerous if problems happen to tyre or rim. The possible burst force tire goes upward and outward, the big power may cause injury or death of the operator or the people around.

Tyre may burst caused by following:

- 1) The wheel rim and the tyre are not of the same size;
- 2) The tyre or the wheel rim is damaged;
- 3) The pressure of tyre inflation is over the max. pressure recommended by manufacturer;
- 4) The operator fail to comply with the safety regulation;

Please operate as follows:

- 1) Remove the valve cap from the valve stem;
- 2) Check to make sure the air nozzle is pressed down completely over the threads of the valve stem.
- 3) Check to make sure that the tyre and the wheel rim are of the same size;
- 4) Lubricate both the tyre bead and the wheel rim, additional lubrication is required if needed;
- 5) Inflate the tyre with break, while inflating, check the pressure listed on the pressure gauge, also check whether the bead is fixed or not. Repeat operation above until the bead is secured; you need take special steps when inflating convex rim or double convex rim;
- 6) Continue inflating and check the air pressure frequently until to reach the required pressure.

Note: Never exceed the max. inflation pressure given by the tyre manufacturer.

Keep hands and your body away from inflating tyres.

Only specially trained persons are allowed to perform the operations, do not allow other to operate or be near the tyre changer.

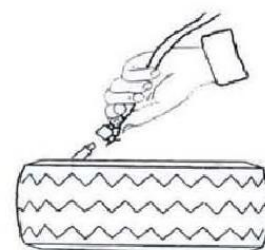

Fig 18

12. Moving machine:

Please use forklift to move the machine. Disconnect the tyre changer from the electricity power supply and pneumatic power supply, lift the base board and insert the feet of forklift. Then mount the tyre changer machine to a new position and fix it tightly.

Note: the place chosen for fixing the tyre changer must meet the safety regulation.

13. Maintenance:

Caution: only the professional persons can do the maintenance. To prolong the machine's life, maintain the machine timely according to the manual. Otherwise, it will impact the reliability of the machine or even cause injury to operator and others nearby.

Caution: before performing any maintenance, disconnect the tyre changer from the electric power supply and pneumatic power supply, and depress the Jaws open and close Pedal or Turntable Rotation Pedal for 3~4 times to evacuate all compressed air from the machine. Damaged parts must be replaced by professional persons with the spare parts provided by manufacturer.

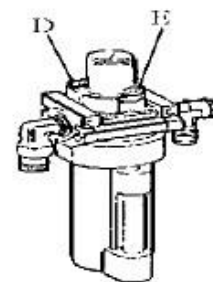

Fig 19

- Clean the machine once every day after work. Clean the dirt on the turntable with diesel oil once per week and lubricate the slides and clamps.

- Following maintenance must be done at least once per month:

Check oil level in Oil Fog Maker, please be filled with SAE30# oil if need.

Unscrew with hex wrench (E). Based on connection of compressed air, first to depress Jaws open and close Pedal or Turntable Rotation Pedal 5-6 times, and then check whether oil in Oil Fog Maker drops down a drip of oil. For continuous operation, depress twice every time, drop down a drip of oil, otherwise adjust the screw (D) that controlled oil enter with minus screwdriver.

(Fig 19)

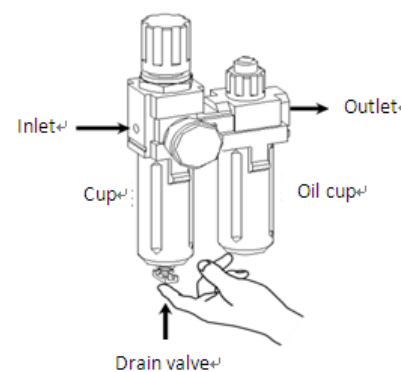

Fig 19-1

- As shown in Figure 19-1, when you found there are some water in the cup, push up the drain valve to drain away water with your fingers; loosen your fingers after drained water, drain valve can be automatic closed under the action of the spring.

Note: After the first 20 days of use, retighten the jaws with tightening screws (B) on the Turntable (Fig 20)

Note: in the event of turntable lose power, check to see if the belt is tight as follow steps: Remove the left side cover by unscrewing the screws; adjust two screws located on the motor support, keep a suitable distance between motor support and motor base; tight the screws for the belt tension.(Fig 21)

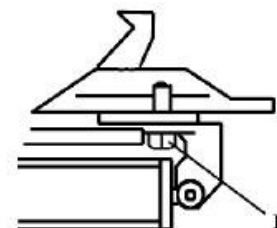

Fig 20

Caution: please disconnect the machine from electric power supply and pneumatic power supply.

Note: If Vertical Arm not be locked or not meet the requirement that 2-3mm from the bottom of Mounting head/demounting head to rim, please adjust Hexagonal Locking Plate, refer to Fig 22 and adjust the (X).

Note: In order to achieve the reliability of jaws and Bead Breaker shovel, operate as follows to keep their valves clean:

1. Remove the left side cover of the machine body by unscrewing the two screws;
2. Loosen the valve mufflers (A) which belong to Jaws open and close Pedal and Bead Breaker Pedal; (**Fig 23**)
3. Clean the mufflers with compressed air, please replace it referring to the spare parts list if it is damaged. (**Fig 23**)

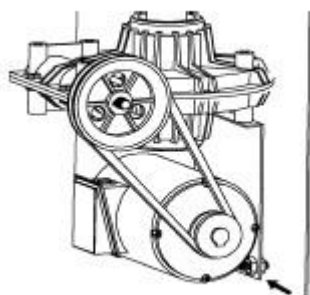

Fig 21

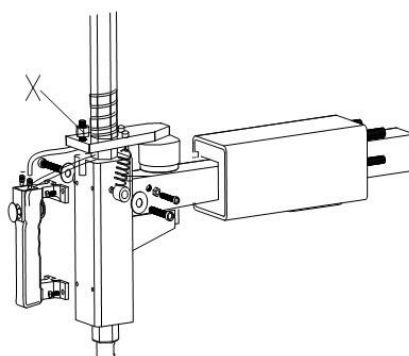

Fig 22

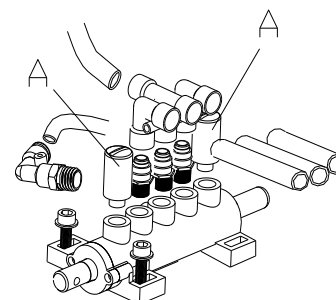
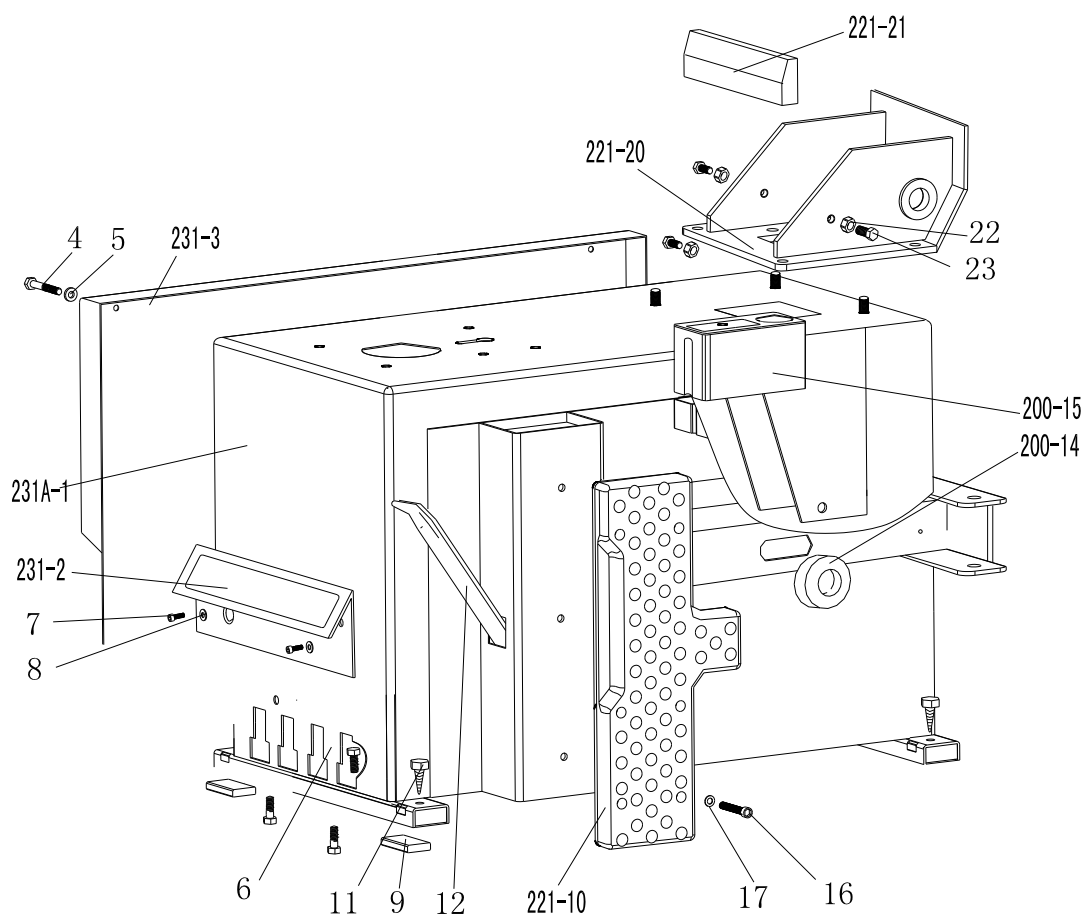

Fig 23

14. Trouble shooting table:

Problem	Reason	Solution
The turntable rotate just in one direction or can't rotate.	Reverse Switch broken	Replace the Reverse Switch
	Belt broken	Replace the belt
	The Motor's malfunction	Check the motor cable or terminal block wire; Replace the motor if it was broken.
Demount or fix the wheel, the turntable can't lock (spin with wheel); The jaws delay to open/close; The turntable locks the rim incorrectly.	Leakage of Air network	Check all the parts on the air network.
	The clamping cylinder can't work.	Replace the cylinder piston.
	Worn jaws	Replace the jaws.
	Broken washers of the chuck cylinder	Replace it.
The mounting head/demounting head always touch the rim during operation.	The locking plate incorrectly adjust or unqualified.	Replace or adjust it.
	Screws on the chuck loose; the Vertical Arm can't be locked by Locking Plate	Tighten the screws; replace the Locking Plate.
The Bead Breaker Pedal and Jaw open and close Pedal can't turn back to the original position.	pedal spring broken	Replace it.
The Bead Breaker shovel operates difficultly.	Jammed silencer	Clean it or replace it.
	The washer on the Bead Breaker cylinder is broken.	Replace it.

15. Exploded drawing:



231A-1	CX-231-010000-0	Machine body
231-2	CZ-231-080000-0	Pedal front cover
231-3	CX-231-020000-0	Left cover
4	B-010-060101-0	Hex socket head bolt M6x10
5	B-040-061412-1	Flat washer $\varnothing 6 \times 14 \times 1.2$
6	B-014-080251-0	Outer hex bolt M8x25
7	B-010-060201-0	Hex socket head bolt M6x20
8	B-040-082220-1	Flat washer $\varnothing 8 \times 22 \times 2$
9	C-000-001020-0	Rubber foot buffer
221-10	C-221-500000-0	Bead breaker buffer
11	B-027-060401-0	Grounding screw M6x40
12	C-200-580000-0	Lifting lever
200-14	C-200-510000-0	Bead breaker arm rubber
200-15	C-200-470000-0	Oil-water box
16	B-010-080201-0	Hex socket head bolt M8x20
17	B-040-081715-0	Flat washer $\varnothing 8 \times 17 \times 1.5$
221-20	CX-221-010106-0	Tilting seat
221-21	C-221-820000-0	Tilting protect cover
22	B-001-100001-0	Self-locking nut M10
23	B-014-100251-0	Outer hex bolt M10x25

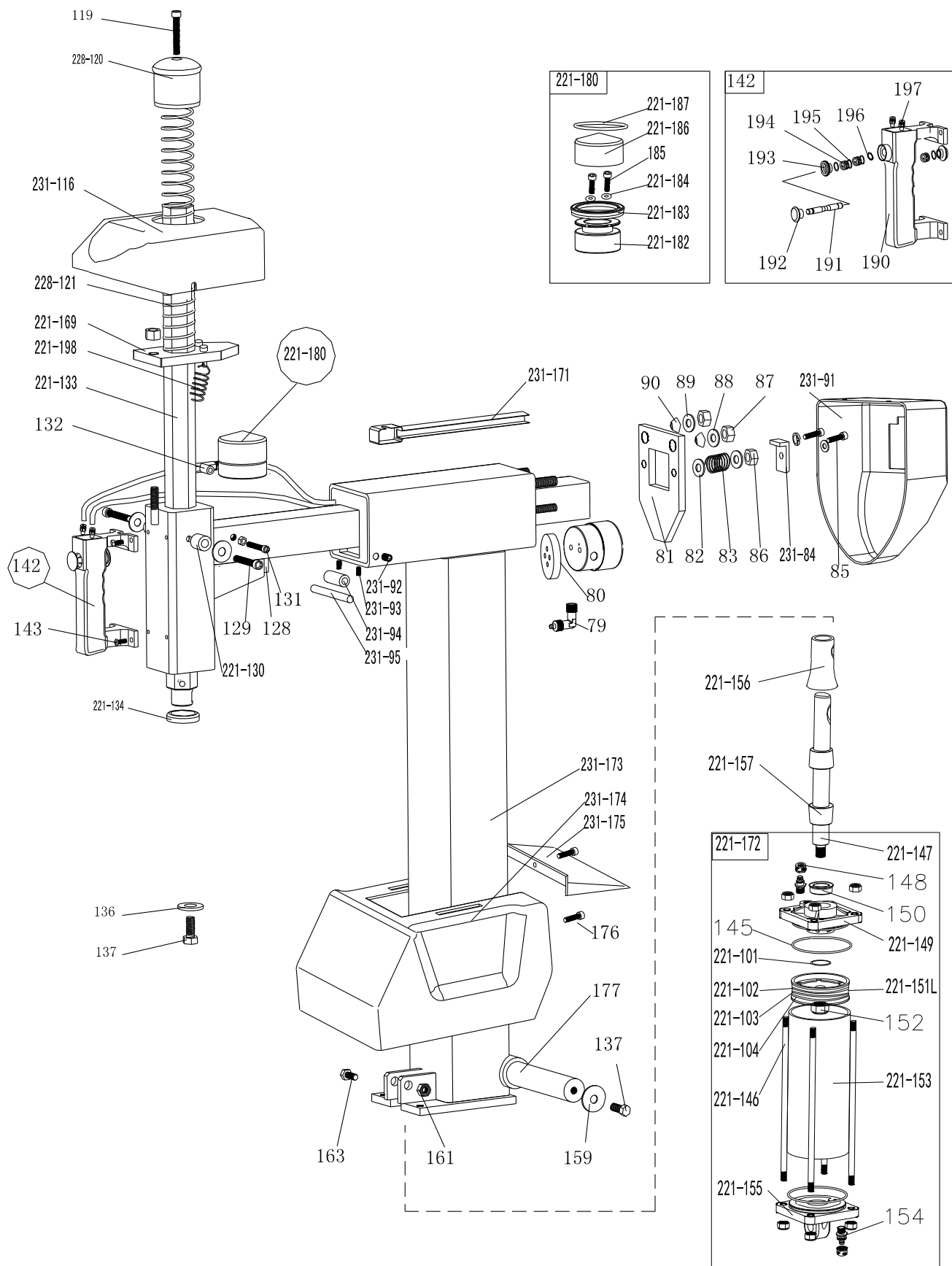

79	S-012-010806-0	Quick union 1/8-Ø6	221-146	C-221-350900-0	Tilting cylinder threaded
80	C-221-250600-0	Locking cylinder plate	221-147	C-221-350200-0	Tilting cylinder piston rod
81	CX-231-190000-0	Horizontal arm locking plate	148	B-001-080001-0	Self-locking nut M8
82	B-040-081715-1	Flat washer Ø8*17*1.5	221-149	C-221-350100-0	Tilting cylinder cover without handle
83	C-221-410000-0	Horizontal arm locking spring	150	S-005-020075-0	V seal Ø20*28*7.5
231-84	CX-231-240000-0	Horizontal arm block	221-151L	C-221-550000-L	Tilting cylinder piston(Al-alloy)φ 75
85	B-014-080201-0	Outer hex bolt M8*20	152	B-004-120071-0	Nut (silver) M12*1.5*7
86	B-001-080001-0	Self-locking nut M8	221-153	C-221-350500-0	Tilting cylinder barrel
87	B-001-120001-0	Self-locking nut M12	154	S-010-010806-0	Straight union 1/8-Ø6
88	B-040-122520-1	Flat washer Φ 12*25*2	221-155	C-221-350300-0	Tilting cylinder cover with handle
89	B-040-122520-1	Flat washer Φ 12*25*2	221-156	CX-221-351000-0	Tilting cylinder piston rod cover
90	C-221-230000-0	Locking spacer	221-157	C-221-350700-0	Tilting cylinder rubber sheath 1
231-91	C-231-780000-0	Horizontal arm protection back cover	159	B-040-104030-1	Flat washer 10*40*3
231-92	B-007-100161-0	Hex socket head bolt M10*16	161	B-001-120001-0	Self-locking nut M12
			163	B-014-120651-0	Outer hex bolt M12x65
231-93	B-007-080161-0	Hex socket head bolt M8*16	221-169	CX-221-220000-0	Hex locking board 221
231-94	CX-231-251300-0	column side pulley	231-171	C-231-790000-0	hose guide
231-95	C-231-251400-0	column side pulley pin	221-172	CW-105-021102-0	Complete titling cylinder
231-116	C-231-480000-0	Horizontal arm protection front cover	231-173	CX-231-250000-A	Column
119	B-010-100501-0	Hex socket head bolt M10x50	231-175	C-231-460000-0	Tilting Column back cover
228-120	C-228-490000-0	Vertical arm cap 228	231-174	C-231-450000-0	Column protection cover
228-121	C-228-390000-0	Vertical arm spring	176	B-024-050161-1	Cross head screw 5*16
128	C-221-200000-0	Shock absorber	177	CX-221-260000-0	Column shaft
129	B-010-060351-0	Hex socket head bolt M6x35	221-180		Complete locking cylinder
221-130	P-120-260000-0	guide pulley	221-182	CZ-221-090100-0	Complete locking cylinder piston
131	B-010-060161-0	Hex socket head bolt M6x16	221-183	S-005-050065-1	V seal Ø50*60*6.5
132	S-017-010806-2	T-union 1/8-2*O6	221-184	S-000-006300-0	O seal Ø5.6X2
221-133	CX-221-160000-0	Vertical arm	185	B-010-060551-0	Hex socket head bolt M6x55
221-134	C-228-520000-0	Vertical arm washer	221-186	CX-221-090200-0	Locking cylinder cover Ø60
135-7#	CW-013-030000-0	Complete Mount/demount head 7#	221-187	S-000-052200-0	O seal Ø52X2
136	CX-200-170000-0	7# Mount/demount head flat washer	190	C-221-210100-0	Pneumatic handle switch plate
137	B-014-100251-0	Outer hex bolt M10x25	191	C-221-210200-0	Pneumatic handle valve rod
300-139	C-300-150000-0	Mount/demount head 7#	192	C-221-210500-0	Pneumatic valve rod cap
300-123	C-2592-150500-0	Mount/demount head flat protection	193	C-221-210300-0	Pneumatic handle cover
300-124	C-200-150400-0	hex round pin	194	C-221-210400-0	Pneumatic handle spacer
300-125	C-2592-150300-0	7# Mount/demount head protection washer	195	S-000-007265-0	O seal 7.5*2.65
141	B-007-120121-0	Hex socket head bolt M12X12	196	B-055-080001-0	Snap ring Ø8
142	CW-119-021100-0	Complete Pneumatic locking switch	197	S-010-010806-0	Straight union
143	B-010-060161-0	Hex socket head bolt M6x16	221-198	C-221-400000-0	Hex locking board spring
145	S-000-068353-0	O seal Ø68*3.5	199	B-007-100121-0	Hex socket head bolt M10x12
221-101	S-000-011180-0	O-seal φ 11*1.8	221-103	S-000-068353-0	O-sealφ 68*3.53
221-102	S-005-065075-0	Y-sealφ 65*75*6	221-104	S-000-065053-0	O-sealφ 65*5.3

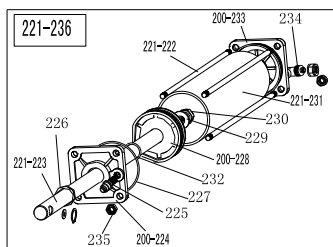
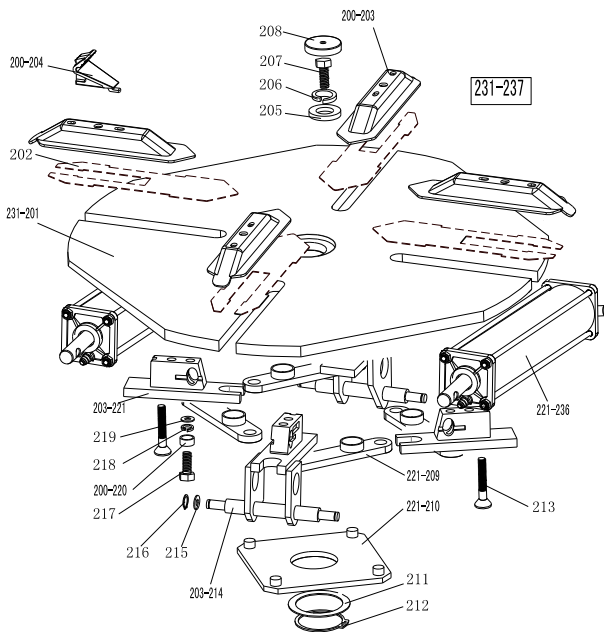

231-201	CX-231-130000-0	Turntable 650
202	CX-221-120300-0	Jaw sliding plate(optional)
200-203	CX-200-120000-0	Jaw cap assembly
200-204	C-200-570000-0	Jaw
205	CX-200-140000-0	Big washer
206	B-050-160000-0	Spring washer Ø16
207	B-014-160401-0	Outer hex bolt M16x40x1.5
208	C-200-440000-0	Turntable cap
221-209	CX-221-310000-0	Connection rod assembly 615
221-210	CX-221-280000-0	Square turntable 615
211	CX-200-290000-0	Square turntable washer
212	B-055-650001-0	Snap ring Ø65(shaft)
213	B-012-120631-0	Hex socket head bolt
203-214	CX-203-110000-0	Jaw slide guide with pin double holes
215	B-040-122520-1	Flat washer Ø12X25X2
216	B-055-120001-0	Snap ring Ø12(shaft)
217	B-014-120801-0	Hex socket head bolt M12x40
218	B-046-122050-1	Teeth locking washer Ø12x20.5x1
219	B-040-123030-1	Flat washer Ø12X30X3
200-220	CX-200-300000-0	Connection rod nut
203-221	CX-203-110100-0	Jaw slide guide without pin double holes
221-222	C-221-100400-0	Threaded connection rod 393
221-223	C-221-100200-0	Clamping cylinder piston rod 400
200-224	C-200-100100-0	Clamping cylinder cover without handle
225	S-011-010808-0	Straight union 1/8"-Ø8
226	S-005-020075-0	V- seal 20*28*7.5
227	S-000-063265-0	O- seal 63*2.65
200-228	C-200-540000-0	Clamping cylinder piston Ø70
229	B-040-122520-1	Flat washer Ø12X25X2
230	B-004-120071-1	Nut M12X7X1.75
221-231	C-221-100500-0	Clamping cylinder barrel 360
232	S-000-019262-0	O- seal Ø19.6X2.62
200-233	C-200-100300-0	Clamping cylinder cover with handle
234	S-018-010808-0	Union 1/8-Ø8
235	B-001-080001-0	Self-locking nut M8
221-236	CW-105-021100-0	Complete clamping cylinder
231-237	CA-004-020300-0	Complete square turntable 650

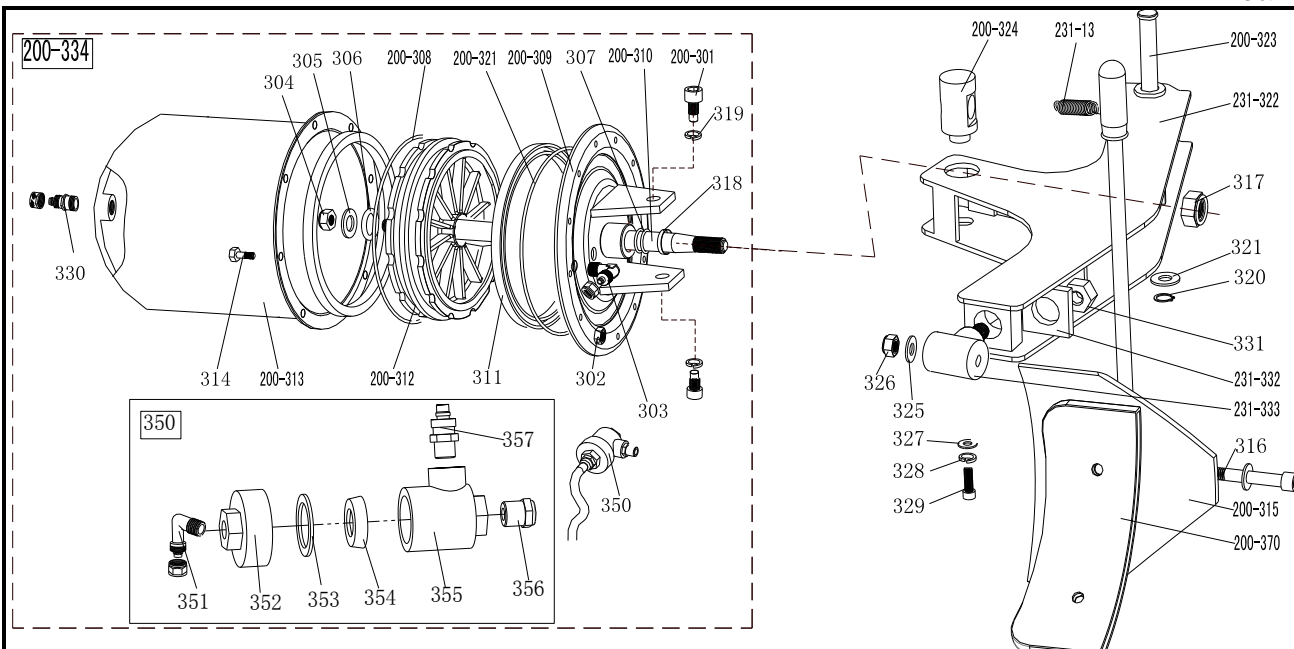

301	B-010-140301-0	Hex socket head boltM14x30	231-13	C-231-360000-0	Bead breaker arm spring
			231-332	CX-231-030900-0	Bead breaker arm rotating shaft spacer
303	S-018-010408-0	Union (90°) 1/4-Ø8	231-333	CX-231-030800-0	Bead breaker arm rotating shaft
304	B-001-160001-1	Nut M16*1.5	228-334	CW-108-209800-0	Complete bead breaker cylinder
305	B-040-162820-1	Flat washer Ø16*28*2	344	B-001-080001-0	Self-locking nut
306	S-000-016265-0	O-seal Ø 16*2.65	350	CW-112-209800-0	Bead breaker cylinder exhaust valve
307	S-000-019262-0	O-seal Ø 19.6*2.62	351	S-012-010808-0	Union 1/8-Ø8
200-310	C-200-050100-0	Bead breaker cylinder piston rod	352	C-098-600200-0	Bead breaker cylinder exhaust valve cover
200-315	CX-200-070000-0	Bead breaker shovel assembly	353	C-098-600400-0	Seal washer
316	B-010-120901-0	Hex socket head bolt M12x90	354	C-098-600300-0	Bidirectional seal
317	B-001-160001-1	Self-locking nut M16*1.5	355	C-098-600100-0	Bead breaker cylinder exhaust valve barrel
318	U-006-000001-1	Guide belt	356	S-023-010401-6	Muffler
319	B-050-140000-0	Spring washer Ø14	357	S-010-010408-0	Straight union 1/4- Ø8
320	B-055-160001-0	Snap ring Ø16	358	CZ-298-050900-0	Nylon cover
321		Flat washer	359	S-005-0200075-0	V-seal20*28*7.5
231-322	CX-231-030000-0	Enlarge bead breaker arm 231	228-361	CX-298-050500-0	Bead breaker cylinder cover assembly
200-323	CX-200-040000-0	Bead breaker pin	228-362	S-000-195265-0	O-sealØ198*3.1
325	B-040-122520-1	Flat washer Ø12*24*2	363	S-005-200184-0	Y-sealD200*184*12
326	B-001-120001-0	Self-locking M12	228-364	C-298-050200-0	Bead breaker cylinder piston D200
331	B-001-160001-0	Self-locking nut M16*1.75	228-365	S-000-180500-0	O-seal 180x5
			228-366	C-298-051000-0	Bead breaker cylinder barrel
			228-367	C-298-050300-0	Bead breaker cylinder back cover
			228-368	C-298-051100-0	Tire pressing shovel protector
			200-370	C-200-070600-0	Bead breaker shovel protection cover(optional)

231-480

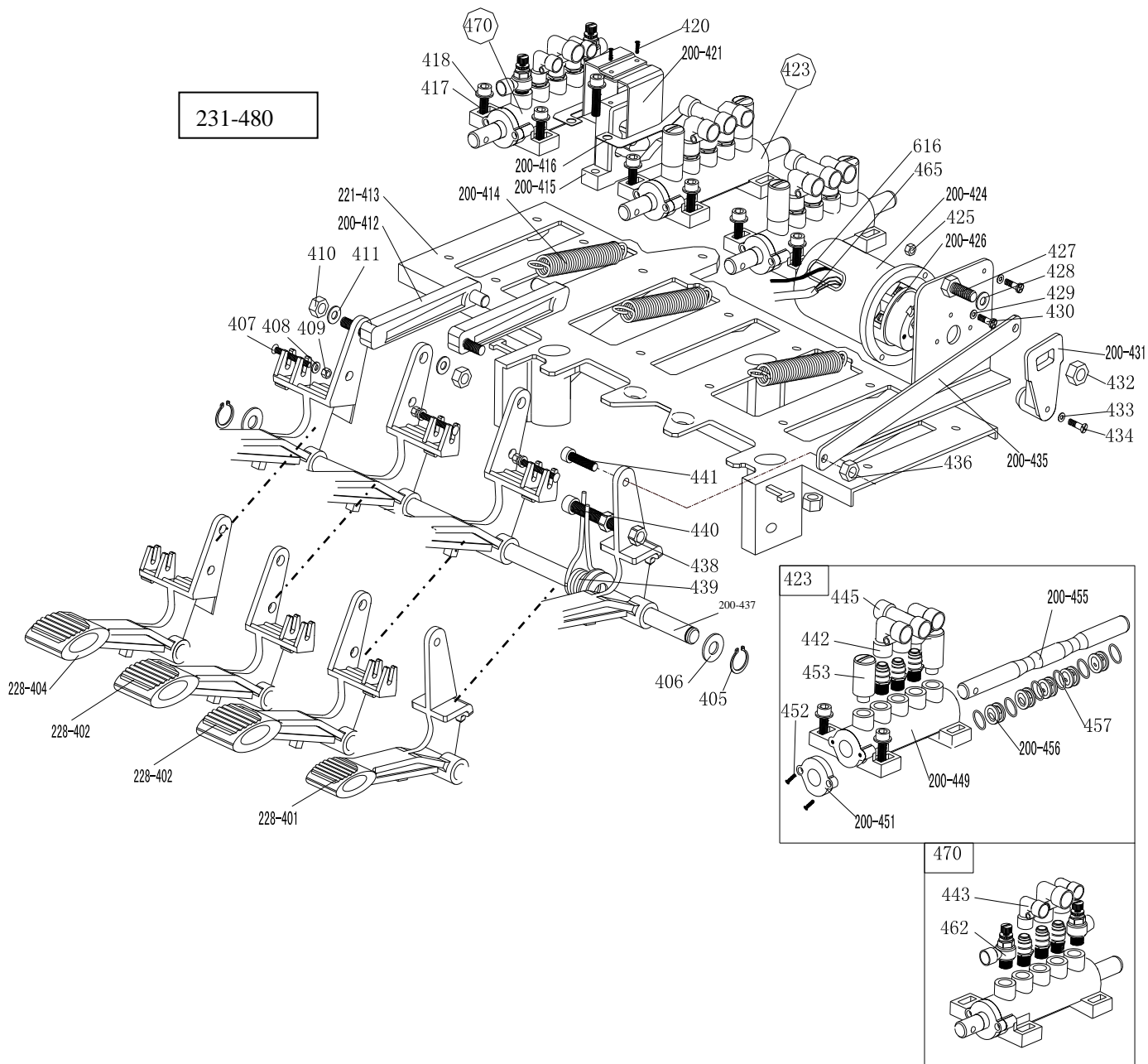

228-401	C-228-060400-0	Reverse switch pedal	429	B-040-040000-1	Flat washer Ø 4
228-402	C-228-060300-0	5-way valve pedal(right)	430	B-024-040161-0	Cross head screw M4*16
228-404	C-228-060200-0	5-way valve pedal(left)	200-431	C-200-530000-0	Reverse switch handle
405	B-055-120001-0	Snap ring Ø12	432	B-001-060001-0	Self-locking nut M6
406	B-040-122520-1	Flat washer Ø12*24*2	433	B-040-030000-1	Flat washer Ø3
407	B-024-040301-0	Cross head screw M4X30	434	B-017-030161-0	Cross head screw M3X18
408	B-040-040000-1	Flat washer Ø 4	200-435	CX-200-060600-0	Pedal connection rod
409	B-001-040001-0	Self-locking nut M4	436	B-001-080001-0	Self-locking nut M8
410	B-001-080001-0	Self-locking nut M8	437	CX-200-060700-0	Pedal front shaft
411	B-040-081715-1	Flat washer Ø8*17*1.5	438	B-004-080001-0	Nut M8
200-412	C-200-061300-0	Cam connection rod	439	C-200-370000-0	Pedal twist spring
221-413	C-221-060100-0	Pedal support board	440	B-010-080501-0	Hex socket head bolt M8x50
200-414	C-200-380000-0	Pedal Spring	441	B-010-080201-0	Hex socket head bolt M8x20
200-415	C-200-061500-0	Cam	442	S-012-010808-0	Quick union1/8- Ø 8
200-416	C-200-810000-0	Cam washer	443	S-012-010806-0	Quick union1/8- Ø 6
417	B-010-060201-0	Hex socket head bolt M6x20	445	S-016-010808-2	Quick T-union1/8-2* Ø 8
418	B-040-061210-1	Flat washer Ø6	200-449	C-200-060901-0	5-way valve barrel (right)
420	B-019-290121-0	Cross head self tapping screw 2.9*12	200-451	C-200-061100-0	5-way valve cover
200-421	CX-200-060500-0	Cam cover	452	B-024-290-121-0	Cross head ST2.9*14
423	CW-110-020001-0	Complete 5-way valve for bead breaker cylinder	453	S-023-010801-0	Muffler 1/8"
			200-455	CX-200-061200-0	5-way valve rod
200-424	C-200-061400-0	Reverse switch cover	200-456	C-200-061000-0	5-way valve rod spacer
425	B-004-040001-0	Nut M4	457	S-000-012400-0	O seal 12*20*4
200-426	S-060-016000-1	Reverse switch	462	S-030-010806-0	Throttle valve
427	B-010-060201-0	Hex socket head bolt M6x20	470	CW-110-021102-0	Complete tilting 5-way valve
428	B-040-061210-1	Flat washer Ø 6X12X1	465	CZ-000-103150-0	Power supply cable
231-480	CW-109-023100-0	Complete 4-pedals assembly 231	616	CZ-000-205150-0	Motor cable

200-526

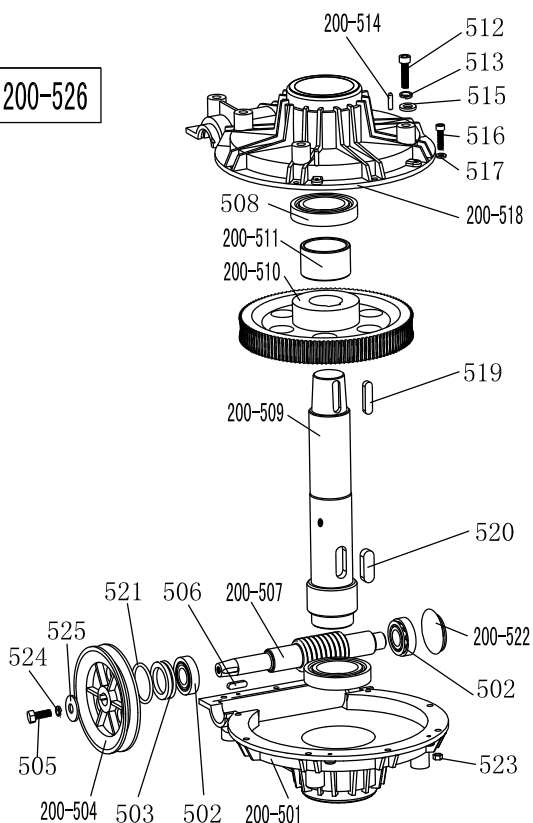

200-501	C-300-320302-0	Gear box lower cover
502	S-040-030204-0	Bearing 30204
503	S-005-020080-1	Gear box seal φ20*35*8
200-504	C-200-320500-0	Gear Belt pulley
505	B-014-080251-0	Outer hex bolt M8x25
506	B-065-006020-0	Key washer 6x20
200-507	C-200-320400-0	Worm rod
508	S-040-006010-0	Bearing 6010
200-509	C-200-320200-0	Worm gear shaft
200-510	C-200-320100-0	Worm gear
200-511	CZ-200-320600-0	Worm gear shaft spacer
512	B-014-100551-0	Outer hex bolt M10x55
513	B-050-100000-0	Spring washer Ø10
200-514	B-060-006020-0	Pin 6X20
515	B-040-102020-1	Flat washer Ø10*20*2
516	B-010-060201-0	Hex socket head bolt M6x20
517	B-040-061412-1	Flat washer Ø 6*14*1.2
200-518	C-300-320301-0	Gear box upper cover
519	B-065-010040-0	Key washer 10x40
520	B-065-014040-0	Key washer 14x40
521	S-000-030355-0	O-seal Ø 30*3.55
200-522	C-200-320700-0	Oil resistant seal
523	B-001-060001-0	Self-locking nut M6
524	B-050-080000-0	Spring washer Ø 8
525	B-040-083030-1	Flat washer Ø 8*30*3
200-526	CW-107-020001-0	Complete gear box

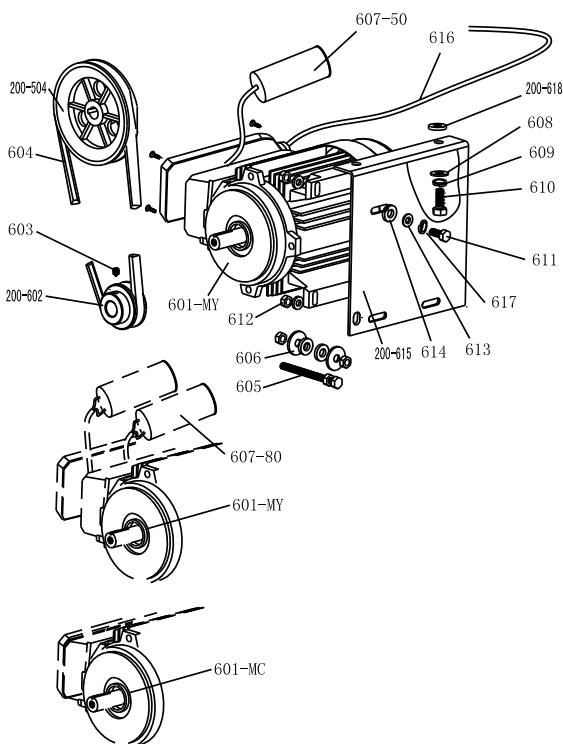

200-504	C-200-320500-0	Gear Belt pulley
601-MC	S-050-220110-5	Motor 220V/50HZ
601-MY	S-050-230075-0	Motor 220v
200-602	CX-200-330000-0	Motor Belt pulley
603	B-007-080121-0	Hex socket head bolt M8x12
604	S-042-000686-0	Tyre changer belt A-28
605	B-014-080651-0	Outer hex bolt M8X65
606	B-040-083030-1	Flat washer Ø8X30X3
607-80	S-063-008000-0	Capacitor 80µf,110V
607-50	S-063-005000-0	Capacitor 50µf,220V
608	B-040-102020-1	Flat washer Ø10X20X2
609	B-050-100000-0	Spring washer Ø10
610	B-014-100251-0	Outer hex bolt M10X25
611	B-014-080351-0	Outer hex bolt M8X35
612	B-004-080001-0	Nut M8
613	B-040-082220-1	Flat washer φ8X22X2
614	C-200-560000-0	Motor rubber washer
200-615	CX-200-340000-1	Motor support
616	CZ-000-205150-0	Motor cable 5x1.0
617	B-050-080000-0	Spring washer φ8
200-618	C-200-560000-0	Motor rubber buffer

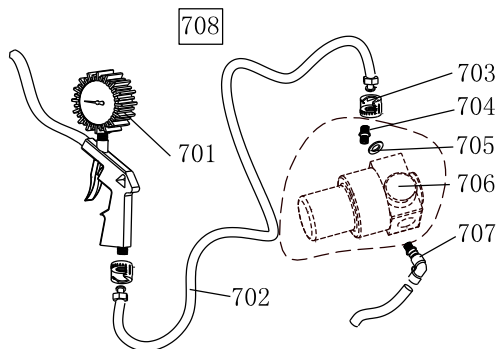

701	S-038-000100-0	Inflating gun indicator
702	CX-001-000002-0	Rubber connection hose
703	S-025-104008-0	Notch nut
704	S-011-010414-1	Straight union 1/4-1/4
705	B-040-132420-1	Flat washer Ø13
706	S-030-010400-2	Pressure adjust valve(optional)
707	S-012-010408-0	Quick union 1/4-Ø8
708	CW-090-000201-0	Complete inflating gun

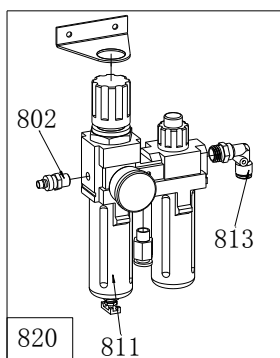

802	S-025-000050-0	Quick union PM20
811	S-033-330000-0	oil fog maker 3300
813	S-018-010408-0	Two-way union 1/4- Ø8
820	CW-114-033000-0	Complete oil fog maker 3300

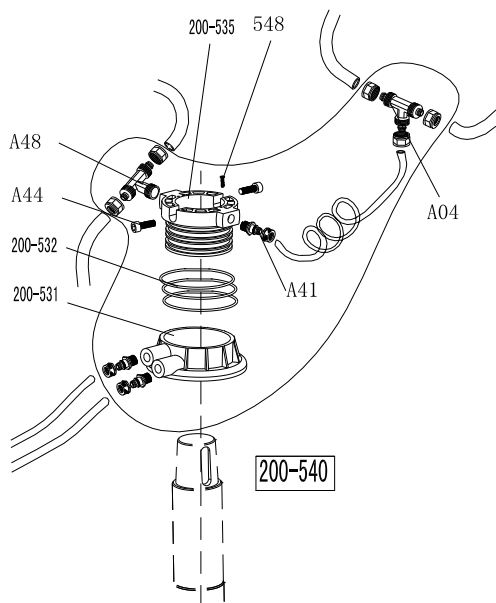

A04	S-015-000008-3	T-union 3* Ø 8
A44	B-010-060161-0	Hex socket head bolt M6x16
A48	S-017-010808-2	Quick T-union
200-531	CZ-200-430100-0	Rotating valve casing
200-532	S-000-059262-0	O-seal 59.9X2.62
200-535	CZ-200-430200-0	Rotating valve mandrel
537	S-035-055080-0	Hose 5.5* Ø 8
A41	S-011-010808-0	Straight union 1/8-Ø8
548	B-007-040061-0	Hex socket head bolt M4X6
200-540	CW-016-020000-2	Complete Rotating valve

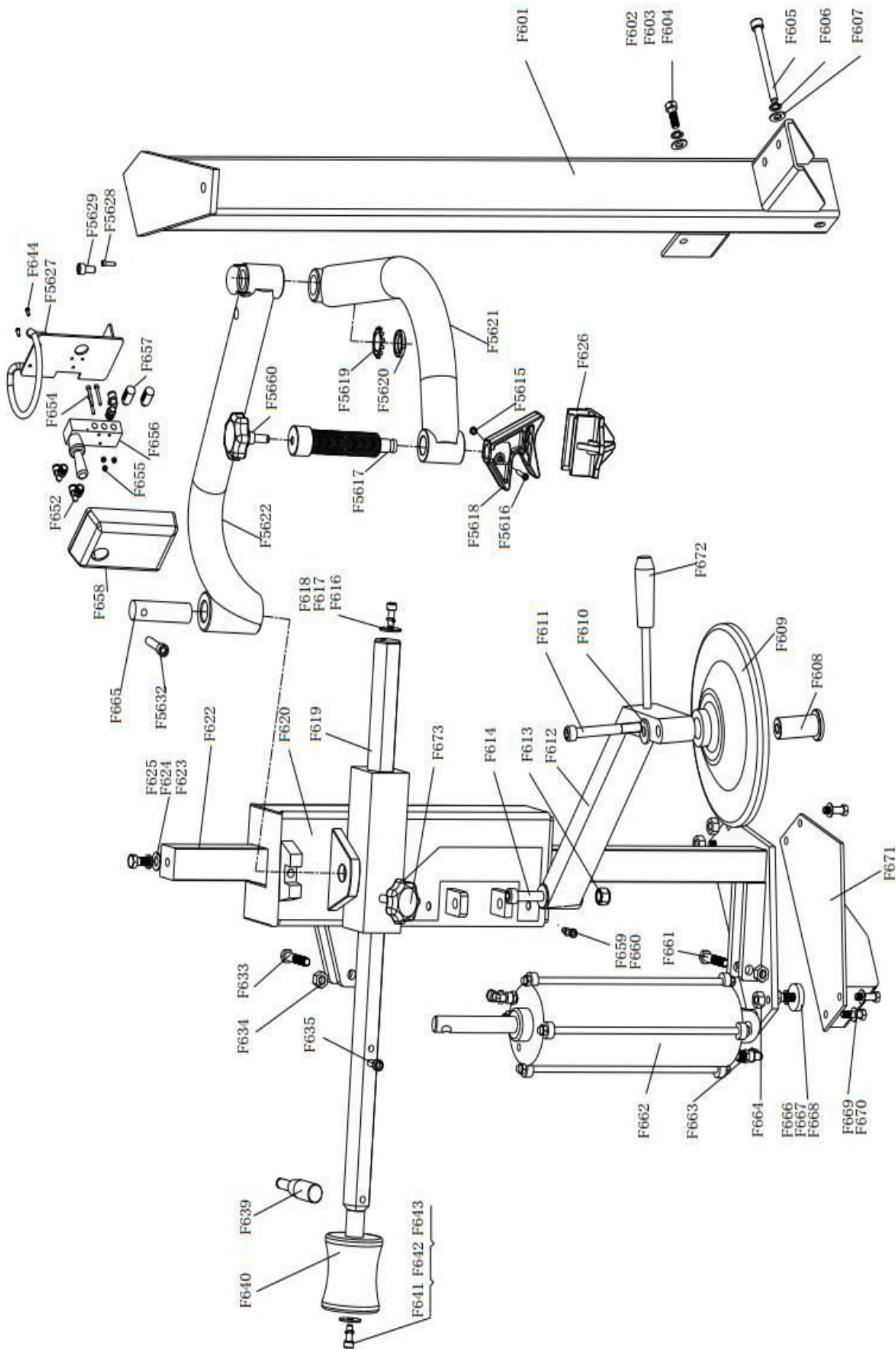

F601	CX-036-010000-0	Column 036	F633	B-014-100551-0	Outer hex bolt M10*55
F602	B-040-102020-1	flat washer Ø10*20*2	F634	B-001-100001-0	self-lock nut M10
F603	B-050-100000-0	Spring washer Ø10*20	F635	B-010-080201-0	Hex socket head bolt M8*20
F604	B-014-100251-0	Outer hexagon bolt M10*25	F639	P-000-009000-0	Handle
F605	B-010-101001-0	Hexagon socket head boltM10*100	F640	C-008-080000-0	Tire pressing pulley
F606	B-050-100000-0	Spring washerØ10*20	F641	B-040-083030-1	flat washer Ø8*30*3
F607	B-040-102020-1	flat washer Ø10*20*2	F642	B-050-080000-0	Spring washer Ø8
F608	CX-005-110000-0	Tire lifting roller hud	F643	B-010-080201-0	Hex socket head bolt M8*20
F609	C-005-100000-0	Tire lifting roller	F644	B-017-040161-0	Cross head screw M4*16
F610	B-040-122520-1	Flat washer Ø12*25*2	F645	B-017-040301-0	Cross head screw M4*30
F611	B-010-121001-0	Hex socket head bolt M12*100	F5627	CX-056-120000-0	Control board assembly
F612	CX-006-060000-0	Tire lifting roller support 006	F5628	B-010-050101-0	Hex socket head bolt M5*10
F613	B-001-120001-0	self-lock nut M12	F5629	B-010-100251-0	Hex socket head bolt M10*25
F614	B-010-121001-0	Hex socket head bolt M12*100	F5632	B-010-120551-0	Hex socket head bolt M12*55
F616	B-040-083030-1	flat washer Ø8*30*3	F652	S-012-010406-0	Quick union 1/4-Ø6
F617	B-050-080000-0	Spring washer Ø8	F653	CX-007-200000-0	Raise-fall switch plate
F618	B-010-080201-0	Hex socket head bolt M8*20	F654	B-024-050101-0	Cross head M5*10
F619	CX-006-170000-0	Horizontal pushing arm	F655	B-001-040001-0	Nut M4
F620	CX-006-030000-0	Raise-fall sleeve 036	F656	S-030-010818-0	Handle valve
F621	CX-036-050000-0	Connecting bolt 036	F657	S-023-010801-0	Muffle 1/8(plastic)
F622	CX-036-020000-1	Square column assembly 036	F658	C-007-181000-0	Control valve protection cover
F623	B-040-102020-1	flat washer Ø10*20*2	F659	B-010-060101-0	Hexagon socket head bolt M6*10
F624	B-014-100251-0	Outer hex bolt M10*25	F660	B-040-061210-1	Flat washer Ø6*12*1
F625	B-050-100000-0	Spring washerØ10	F661	B-014-100551-0	Outer hexagon bolt M10*55
F626	C-008-090200-0	Tire pressing head (low)			
F5615	B-001-060001-0	Nut M6	F662	C-006-040100-0	Raise-fall cylinder 006
F5616	B-010-060301-0	Hex screw M6*30	F663	S-012-010806-0	Quick union 1/8-Ø6
F5617	C-056-140000-0	Tire pressing head spindle	F664	B-001-080001-0	Self-lock nutM8
F5618	C-008-090100-0	Tire pressing head (Upper)	F665		Connecting pin
F5619	B-045-000027-0	Lock washer	F666	B-014-100251-0	Outer hex bolt M10*25
F5620	B-004-270001-1	Round nutM27	F667	B-050-100000-0	Spring washerØ10*20
F5621	CX-056-070000-0	Tumbler rod assembly2	F668	CX-200-170000-0	Mount/demount head flat washer
F5622	CX-056-060000-0	Tumbler rod assembly 1	F669	B-040-081715-1	Flat washer Ø8*17*1.2
			F670	B-014-080301-0	Outer hex bolt M8*30
			F671	CZ-006-140000-0	Help arm support plate
			F672	C-200-230200-0	Locking handle cover
			F5660	C-238-201501-0	Adjusting handle

16. Circuit diagram:

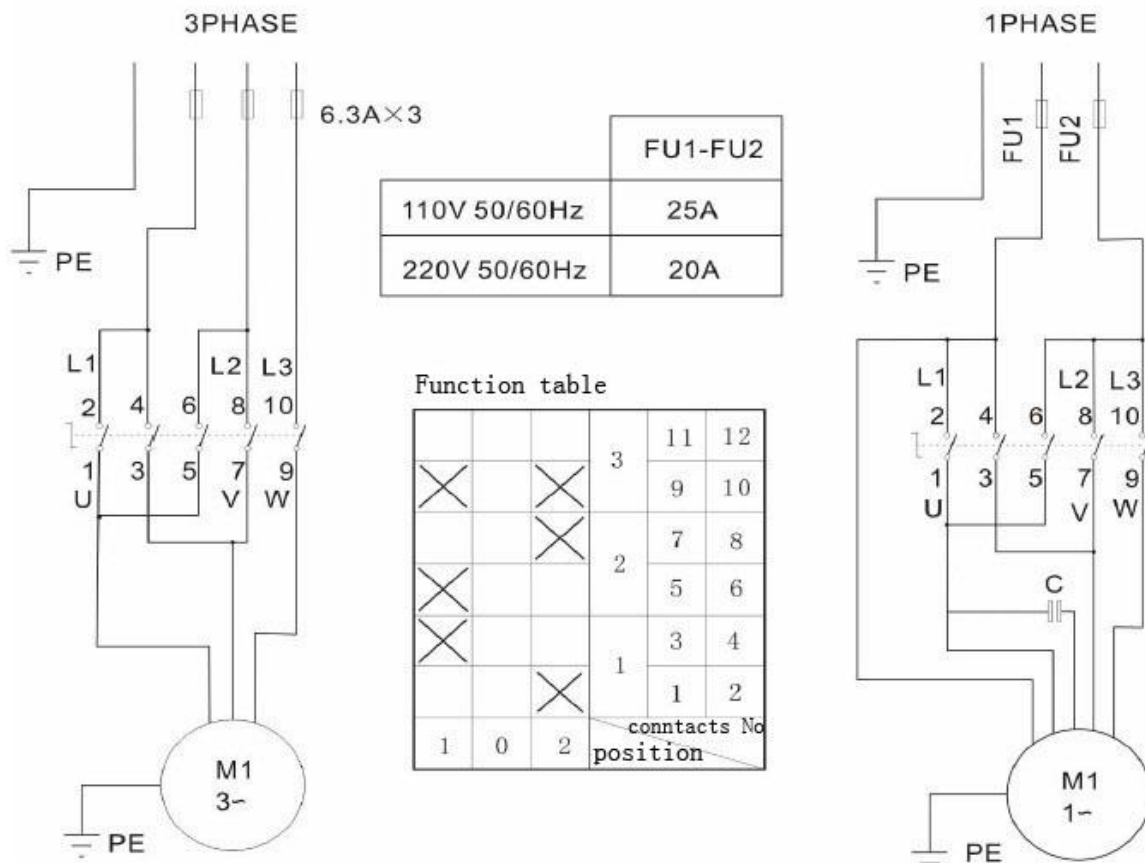

17. Pneumatic drawing:

