

Joel's GARAGE GEAR

INSTALLATION GUIDE/ OWNERS MANUAL



JGG-40SF

4000KG 2 POST BASE PLATE HOIST

CONTENTS

TECHNICAL SPECIFICATIONS 3

CONCRETE FOUNDATION SPECIFICATIONS AND REQUIREMENTS 3

OWNER /INSTALLER RESPONSIBILITIES:..... 4

IMPORTANT INFORMATION:..... 4

SHIPPING DAMAGE/MISSING PARTS CLAIMS 4

LIMITATION OF LIABILITY 4

PRODUCT WARRANTY 5

 WHAT IS NOT COVERED BY THE PRODUCT WARRANTY 5

INSTALLATION TOOLS REQUIRED:..... 6

PRE-INSTALLATION PROCEDURES 7

 SELECT LIFT LOCATION:..... 7

 FLOOR REQUIREMENTS: 7

 CEILING REQUIREMENTS: 7

 DEFECTIVE CONCRETE: 7

HOIST LOCATION LAYOUT 8

IMPORTANT AND GENERAL INFORMATION FOR EXPANSION ANCHORS 8

EXPANSION ANCHOR INSTALLATION INSTRUCTIONS 20mm X 140mm 9

CAR LIFT DIMENSIONS 10

CAR LIFT GENERAL ASSEMBLY COMPONENTS 11

INSTALLATION PROCEDURE..... 13

 UNPACKING THE HOIST 13

INSTALLING THE SUB BASE FRAME & COLUMNS 14

INSTALL COLUMN EQUALIZER CABLE 15

 DRILLING NOTES FOR EXPANSION ANCHORS..... 16

 INSTALLING EXPANSION ANCHORS AND LEVELING THE COLUMNS 16

INSTALL THE POWER UNIT 17

INSTALL THE HYDRAULIC SYSTEM HOSES 17

CONNECT ELECTRICAL TO THE POWER UNIT;..... 19

INSTALLING LIFT ARMS..... 20

AIR PURGE PROCEDURE 22

SYNCHRONIZING EQUALIZING CABLES AND LOCKS 23

POST INSTALLATION PROCEDURE:..... 24

OPERATION MANUAL 25

OPERATOR TRAINING AND SAFE PRACTICES..... 26

GENERAL RULES..... 26

SAFETY

TECHNICAL SPECIFICATIONS

Description	Metric (mm) (kg)
Lift capacity	4000kg (4 ton)
Motor	240v 20a single phase
Max rise from the ground	1930mm
Overall height	2866mm
Overall width	3546mm
Drive through clearance	2584mm
Base plate drive over height	50mm
Lifting arm minimum length	615mm/ 890mm
Lifting arm maximum length	1150mm/ 1390mm
Lifting pad minimum height	140mm
Lifting pad maximum height	190mm
Lifting time	50 seconds
N.w./ g.w	680kgs/ 700kgs
Minimum concrete thickness	135mm
Oil tank capacity	10 litres

CONCRETE FOUNDATION SPECIFICATIONS AND REQUIREMENTS

2-Post Hoist 4000kg. 135mm Min. Thickness / 32MPa, RL1018 mesh.

Safe Operating Temperature is between 4°C - 41°C.



OWNER /INSTALLER RESPONSIBILITIES:

DO NOT PROCEED WITHOUT READING THIS MANUAL

It is vital that you carefully read and fully understand all **ASSEMBLY INSTRUCTIONS** before installing this product. Failure to follow the safety rules and basic safety precautions described and presented in this manual may result in serious personal injury including death.

If you have any questions or experience problems, please call our Customer Support department on **1800 563 574**, Monday-Friday. 8.30 a.m.- 4.30 p.m. Melbourne Time.

All repairs are only to be performed by authorised or qualified technicians.

By proceeding you acknowledge and agree that you will fully comprehend and understand the contents of this manual.

IMPORTANT INFORMATION:



WARNING: Do not allow other people to assemble this product until they have read this manual and have developed a thorough understanding of how the product works.

The **JGG-40SF, 2 Post Hoist** (rated at 4000kg's) is designed for **indoor use only** and should not be installed in a pit or on an uneven surface. The floor on which the hoist is installed must have a **minimum thickness of 135mm concrete** substrate, reinforced with steel bar (RL1018) with a minimum compressive strength of **32MPa**. (If you are unsure of this requirement, we strongly recommend you contact your builder or architect for information before installing on pre-stressed concrete.)

This hoist has specific electrical and physical height requirements as described in the installation section of this manual. **Failure by the owner to provide and meet the recommended shelter, mounting surface, electrical supply, and ceiling height can result in unsatisfactory hoist performance, property damage, personal injury or both. Failure to comply with these basic requirements will void any warranty on the product.**

SHIPPING DAMAGE/MISSING PARTS CLAIMS

Any freight damage or lost parts (where visible) must be noted on the freight bill before signing off and must be reported to Joel's Garage Gear to establish a freight claim. When unpacking the product carefully check that all components are provided – refer to the complete parts list provided at the end of this manual. If shortages are discovered, please contact Joel's Garage Gear immediately with a missing part/s list.

LIMITATION OF LIABILITY

The **manufacturer and Joel's Garage Gear** are not and will not be held responsible for any liability for loss, damages of any kind expressed or implied, injury, and or damage to your property or otherwise caused by improper installation, use of this product or neglect on your or the operators' actions.

PRODUCT WARRANTY

WHAT IS NOT COVERED BY THE PRODUCT WARRANTY

- Any failure that results from owner/operator abuse, neglect or failure to operate, maintain or service product in accordance with instructions provided in the owner's manual.
- Any damage caused by overloading lift beyond rated capacity.
- General service on a regular basis is required to maintain the product, i.e. lubricants, oil, etc.
- General wear-n-tear of parts such as rubber pads, etc. unless wear or failure is a direct result of manufacturer defect due to material and/or workmanship.
- Any failure caused by installing or operating lift under conditions not in accordance with installation and operation guidelines or damaged by contact with tools or surroundings.
- Motor or pump failure caused by exposure to moisture/water, excessive humidity, corrosive environments or other contaminants.
- Rusted components due to improper maintenance or corrosive environments.
- Cosmetic defects that do not interfere with product functionality, such as scratched paint.
- Damage due to incorrect voltage or improper wiring.
- Any incidental, indirect, or consequential loss, damage or expense that may result from any defect, failure or malfunction of the product.

INSTALLATION TOOLS REQUIRED:

Please ensure you have all the necessary tools and equipment listed below to successfully complete the installation. **We recommend that you use safety protective clothing and eyewear when installing the hoist.**

- 8m. Measuring tape
- Chalk line and chalk or equivalent
- Heavy duty metal wire cutters
- 1mtr. Crowbar
- Full set of metric wrenches and ratchet set
- Full set Imperial wrenches and ratchet set
- Full set metric and Imperial Allen keys
- 30mm Socket and Calibrated Torque Wrench
- Hammer
- Rubber mallet
- Phillips screwdriver
- Flat blade screwdrivers
- Snap ring pliers.
- 2 x 3mtr. Step ladders
- 1m. Sprit Level
- Rotary hammer drill
- 20mm diameter masonry drill bit
- Lifting devices such as a crane or forklift*
- 100mm x 100mm wooden blocks (use for unpacking)
- Gloves
- *Additional help if no lifting devices available

PRE-INSTALLATION PROCEDURES

Before installation, check and confirm the following:

SELECT LIFT LOCATION:

Always use architects building plans when available. Check layout dimensions against floor plan requirements making sure that adequate space is available on both the sides and in height.

FLOOR REQUIREMENTS:

The hoist should be located on a level floor with less than **3 degrees' slope**. If unsure, consider a survey of the proposed location and/or the possibility of pouring a new level concrete slab. This hoist can only be installed on a concrete floor which conforms to the specifications detailed in this manual. Columns are supported only by anchoring to concrete floors. Failure to do so could cause personal injury or death. **DO NOT INSTALL** the hoist on asphalt. **DO NOT** locate this machine in a recessed area or below floor level. **ALLOW FOR ADEQUATE AND PROPER DRAINAGE.**

CEILING REQUIREMENTS:

The area where the hoist will be located should be free of overhead obstructions such as heaters, building supports, electrical lines, etc.

DEFECTIVE CONCRETE:

Visually inspect the site where the hoist will be installed and check for cracked or defective concrete. If the proposed location is in question, **DO NOT INSTALL THIS HOIST**. If you have any questions and concerns with the hoist location selected contact your local builder or architect. (*Note - A qualified person should be consulted to address seismic loads and other local or state requirements*)

JOEL'S GARAGE GEAR WILL NOT BE HELD RESPONSIBLE OR LIABLE FOR ANY CONCRETE THAT MAY OR MAY NOT MEET SLOPE REQUIREMENTS. IT IS COMPLETELY THE OWNER'S RESPONSIBILITY TO ENSURE THAT THE CORRECT SUBSTRATE FLOORING IS TO THE REQUIRED SPECIFICATIONS. JOEL'S GARAGE GEAR WILL NOT BE RESPONSIBLE FOR ANY CHARGES RELATING TO NEW CONCRETE SLABS POURING, LEVELING OR DAMAGE

HOIST LOCATION LAYOUT

Before any installation can occur, we recommend first completing a layout of the hoist location. The minimum bay size required (that is free unobstructed space) to install is 6000mm [L] x 3600mm [W] x 3000mm [H]

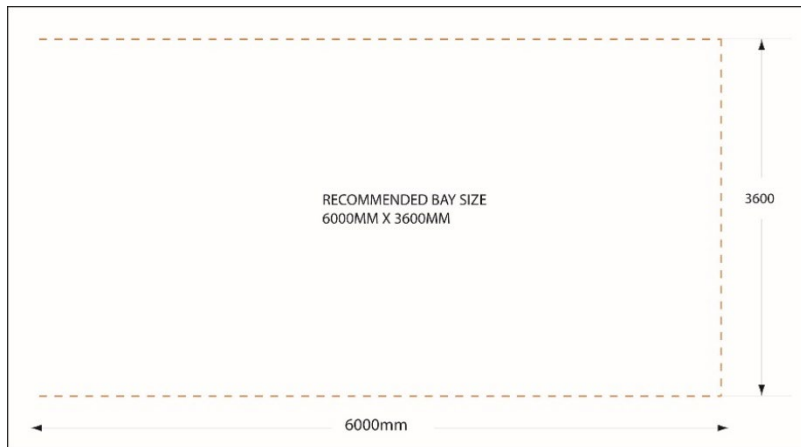

IMPORTANT AND GENERAL INFORMATION FOR EXPANSION ANCHORS

General Instructions for Installing Concrete Anchors

These general instructions for the installer are provided to ensure the proper installation of Expansion Anchor Products.

- The Concrete substrate shall have compression strength of at least **32MPa** using RL 1018 Mesh and a minimum thickness of 135mm.
- A minimum distance of 200mm must be maintained from any slab edge or seam. Hole to hole spacing should be a minimum 165mm in any direction. The hole depth should be a minimum of 110mm.
- Each anchor must be seated to a minimum depth of 85mm. **NOTE:** If the top of the anchor exceeds 55mm above the floor the anchor depth is not deep enough, which will cause the anchor to fail.
- Do not modify or change Mechanical Wedge Anchor products. The manufacturer will not warrant or guarantee the performance of any modified products which will void the product warranty.
- Do not alter installation procedures from those set forth in this Manual.
- Drill holes for mechanical anchors with carbide-tipped drill bits that meet the diameter requirements of ANSI B212.15. A properly sized hole is critical to the performance of mechanical anchors.
- Rotary-hammer drills with light, high frequency impact is recommended for drilling holes.
- Do not use excessively worn bits or bits which have been incorrectly sharpened.
- Please note that the use of oversized holes is **NOT** permitted for anchoring any lift. **DO NOT USE** Anchor Adhesive to fill spacing of oversize holes. Move lift location and Re-drill to correct hole Specification.
- Do not disturb, bolt up, or apply load to adhesive anchors prior to the full cure of any adhesive.
- Metal anchors and fasteners will corrode and may lose load-carrying capacity when installed in corrosive environments or exposed to corrosive materials. There are many environments and materials which may cause corrosion including ocean salt air, fire-retardants, fumes, fertilizers, preservative-treated wood, dissimilar metals, and other corrosive elements.

EXPANSION ANCHOR INSTALLATION INSTRUCTIONS 20mm X 140mm

Anchor size is same as drill bit size 20mm.

Use a hammer drill with a Carbide tip, 20mm diameter, solid drill bit. The bit tip diameter should be ANSI Standard B95.12-1977. 2003 and 2006 IBC compliant high-performing medium-duty expansion anchor.

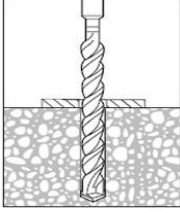
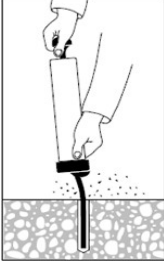
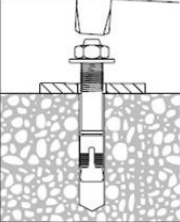
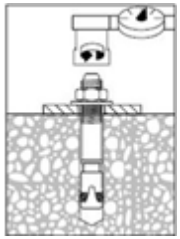
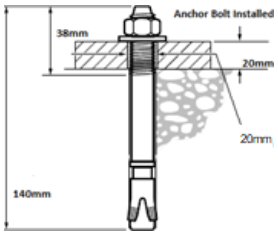
	<p>Hammer drill a hole to the same diameter as the expansion anchor (in this case 20mm). Use the baseplate as a drilling template to ensure proper anchor locations. Drill hole to minimum of 85mm.</p>
5 	<p>Clean hole completely. Remove dirt and dust with the use of a shop vac or an air compressor</p>
	<p>Assemble the flat washer and nut flush on the anchor bolt, leaving about 2mm exposed above the nut. Drive the expansion anchor into the hole using a hammer and wood. If shimming is required, make sure to leave threads exposed for proper shimming</p>
	<p>Tighten the nut to the recommended installation torque</p>
	<p>Installation Complete</p>

CAR LIFT DIMENSIONS

Take note of the sizes of the internal opening of the hoist. You must account for raising arms at the base which will narrow the opening. The following identifies the sizing of the bay area at the base on the hoist. This is the distance that will be available to drive the vehicle through.

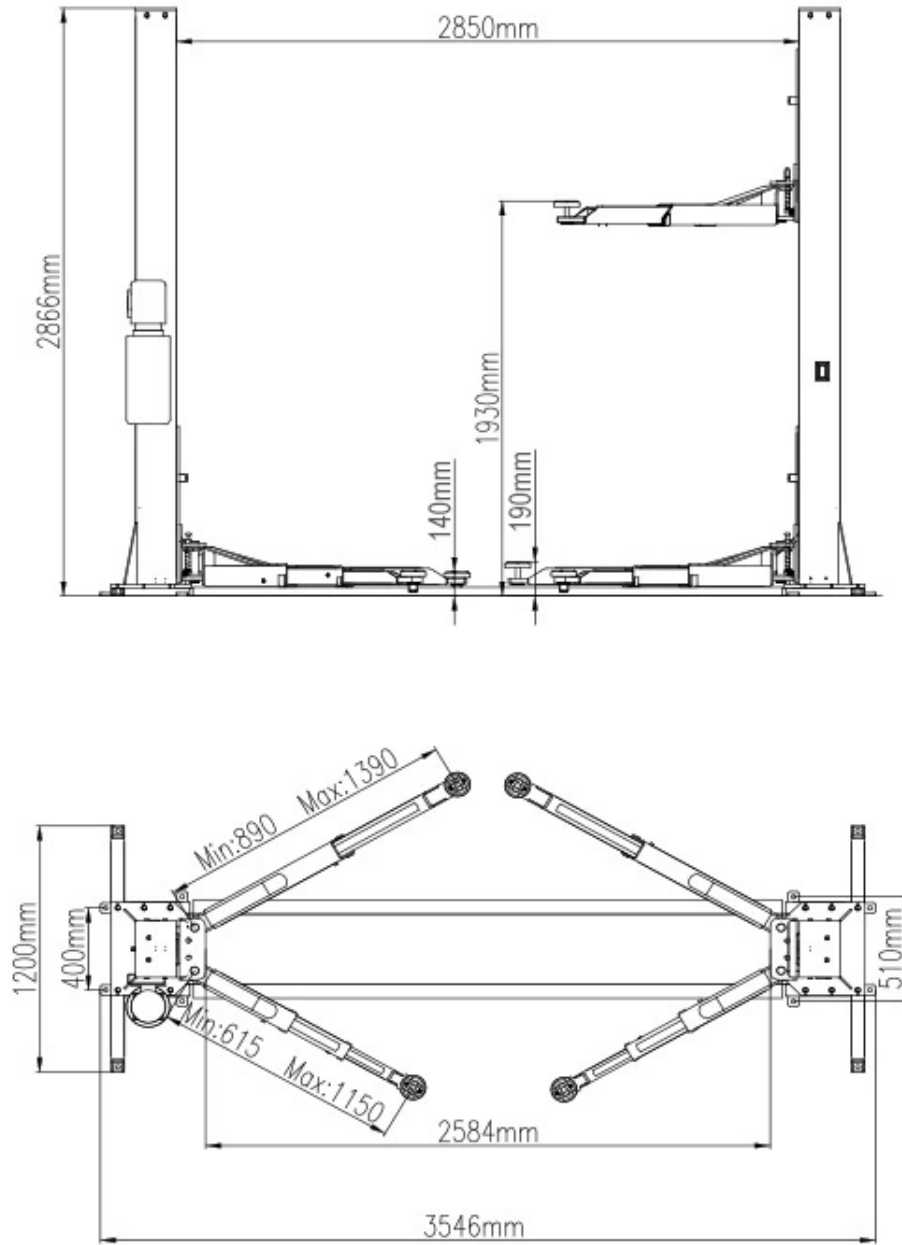

CAR LIFT GENERAL ASSEMBLY COMPONENTS

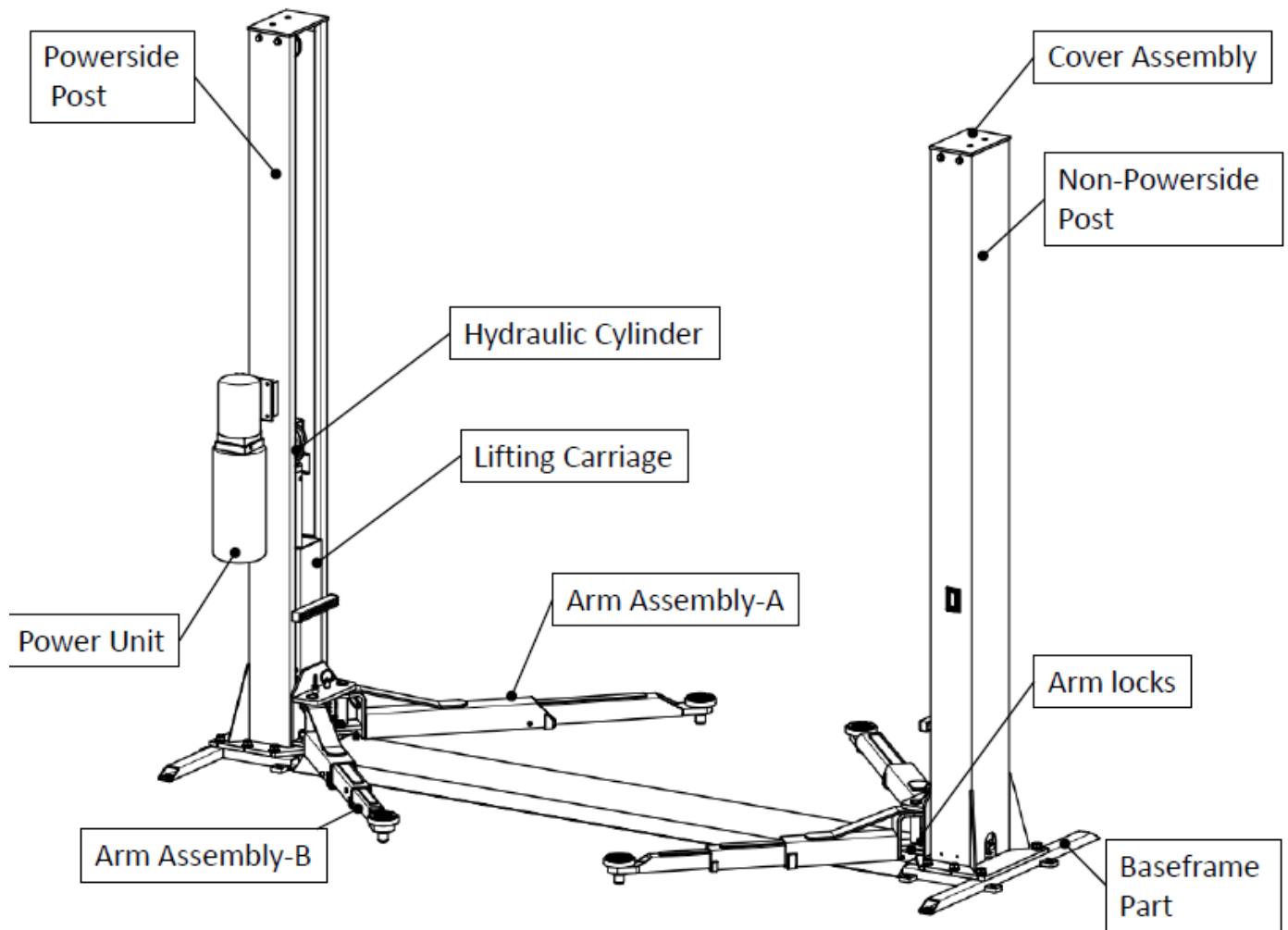

CAR LIFT GENERAL ASSEMBLY COMPONENTS.con't

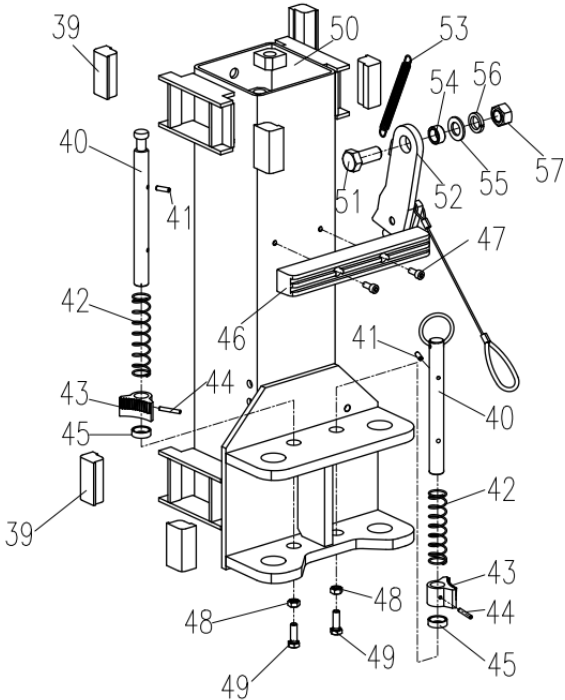
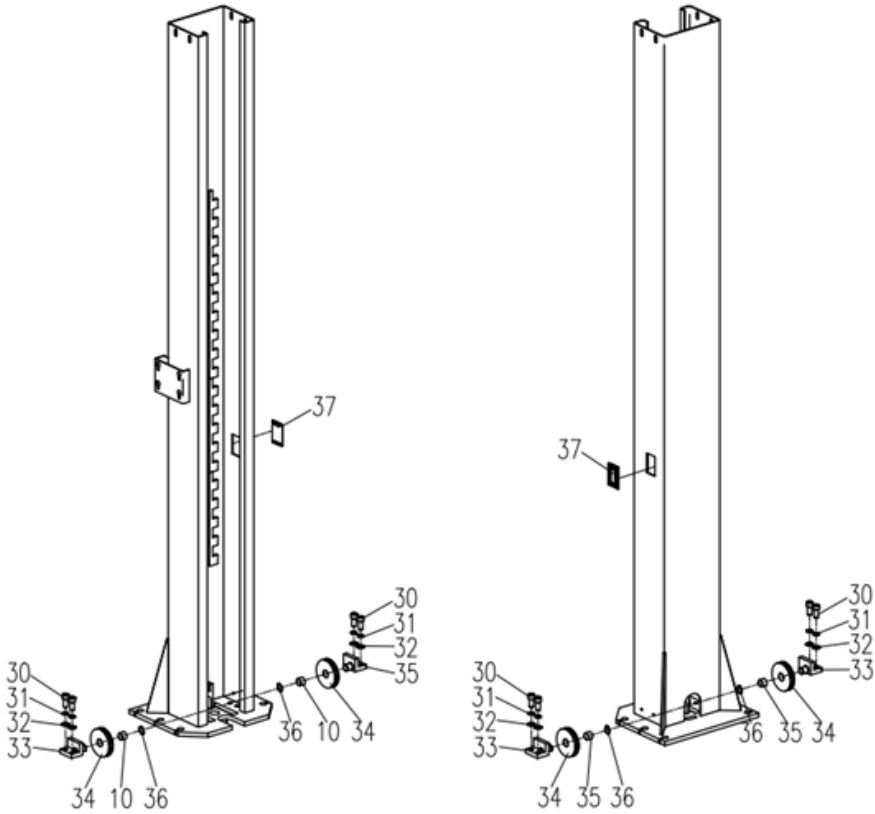

INSTALLATION PROCEDURE

If you are installing this hoist as a DIY install, it is strongly recommended that you have at least one other person as extra help or have heavy duty lifting equipment when unloading and assembling the hoist. Never attempt to lift components without proper lifting tools such as sling bands, forklift or crane. Be aware and stay clear of any moving parts that can fall and cause injury.

UNPACKING THE HOIST

- When unloading the hoist, place it as near as possible to the intended installation location.
- The power unit package is located on the top and should be unpacked first. **Note:** The power unit is heavy, be careful not to drop the power unit. Place the power unit aside out of the way.
- Start by first removing the shipping bands and packing materials from the hoist. Open the wrapping, remove the parts and parts boxes from the packaging.
- Using the parts list contained check that all parts are accounted for. If **any parts are missing**, please advise Joel's Garage Gear immediately.
- Unbolt the structure from the shipping brackets. (Where available use proper lifting devices, cranes or a forklift to lift off shipping brackets.)

INSTALLING THE SUB BASE FRAME & COLUMNS

Start by first placing the hoist sub-base frame in the centre of the bay area. As the columns are bolted to the top left- and right-hand sides of the sub-frame this will provide an exact position and visual reference of where the columns will be located.

With the sub-frame in position put the base plate cover over the top of the sub-frame. Drive a vehicle over the plate to ensure there are no issues getting on or off, the position is suitable to the surrounds and there are no obstructions in the way.

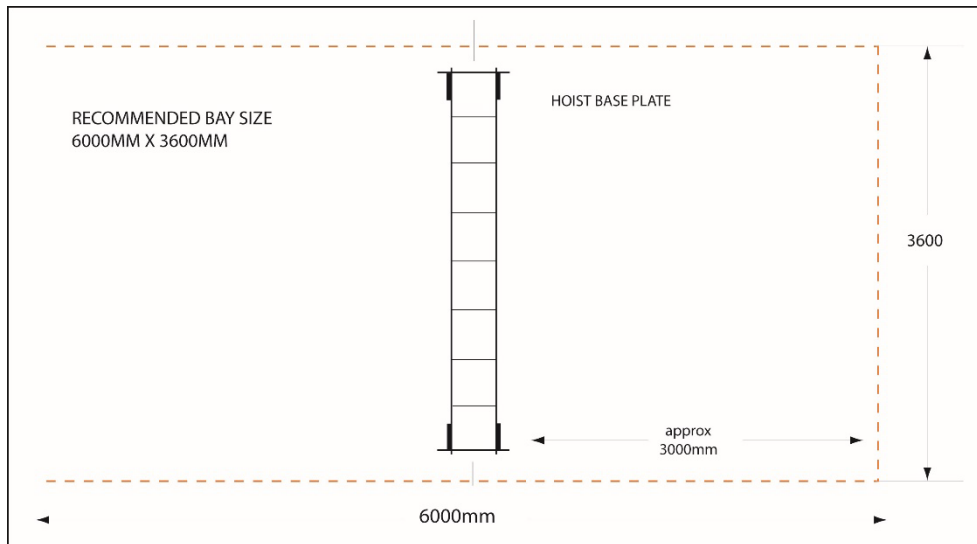

Remove the base plate.

Next, using a hammer drill, carefully drill into the concrete using two side holes **only** of the sub-frame base plate as a guide, do not drill the out-rigger holes until after the columns are installed.

To install the expansion anchor/s, place a flat washer and hex nut over threaded end of the 20mm x 140mm anchor, and screw down the nut leaving approximately 2mm of thread exposed above the nut. Carefully tap the anchor (use a hammer and a block of wood) until it is well seated in the hole with the nut and flat washer against base plate. Do not damage threads. Do not overly tighten the nut at this stage.

After securing the sub-frame base position the columns on the floor each side of the sub frame. Pay attention to where the motor will be positioned as only one column has pre-drilled holes for the motor installation. (Normally right-hand side) (do not raise the columns) With the columns still lying down run the equalizer cables through and across the sub-frame as described below.

INSTALL COLUMN EQUALIZER CABLE

With the columns on the floor install the Equalizer Cable on rear side of the column as shown in the diagram and tighten securely.

Route the equalizer cables in each column as illustrated [4].

Start by making sure the cable is routed down toward the pulley on the base plate (See below) then routed across and under the front sub-frame strap towards the other column.

Remove the access panel on the front of the other side column. Feed the equalizer cable around the lower sheave then up the column and through the top sheave then back down to the mounting carriage.

Leave as much cable slack as possible so there is no tension on the columns when lifting into place.

[4]

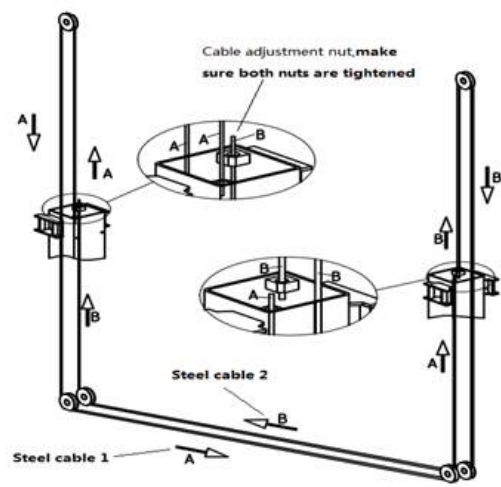

With the equalizer cables installed **raise each column and position it on the sub-frame**. Pay particular attention to the column position. Double check each column is placed in the right position.

To secure the columns, work from the left-hand side first. Using the M20 bolts affix each column to the sub-frame.

With the columns upright and fastened to the sub-frame, secure the equalizer cables and ensure that they are tightened removing as much slack as possible.

With the columns now affixed to the sub-frame it is time to attach the sub-frame to the concrete floor. Drill the holes on the out-rigger position using the sub-floor base as a template. Use compressed air to clean out the holes before inserting the bolts. Once completed tighten all anchor bolts down until firmly secured.

DRILLING NOTES FOR EXPANSION ANCHORS.

CAUTION: Anchors must be at least 200mm from the any edge of the slab or any seam.

- Use only the recommended bit size (20mm) and type - masonry.
- Keep the drill in a perpendicular line while drilling.
- Let the drill do the work. Do not apply excessive pressure. Lift the drill up and down occasionally to remove residue to reduce binding.
- Drill the hole to a depth equal to the length of anchor. **Note:** Drilling all the way through the concrete will allow the anchor to be driven through the bottom of foundation.
- After drilling blow the dust from the hole.

INSTALLING EXPANSION ANCHORS AND LEVELING THE COLUMNS

- Using a spirit level, check the columns are both plumb. If the column is not plumb, using the horseshoe shims provided, shim the column base as required until each column is plumb. If one column has to be elevated to match the plane of the other column, add shim plates. Shim thickness **MUST NOT** exceed 5mm when using the 140mm long anchors provided with the lift.
- Once the columns are both plumb and in position, complete the installation of the remaining anchor bolts by drilling the remaining holes on the sub floor base. Use the sub-base anchor points as a template for drilling the holes.
- When installing the expansion anchors, like previously instructed, place a flat washer and hex nut over the threaded end of 20mm x 140mm anchor, leaving approximately 2mm of thread exposed carefully tap anchor (use a hammer and a block of wood). Do not damage threads. Tap anchor into the concrete until nut and flat washer are against base plate.
- Tighten the nuts on each bolt two or three turns. Check each anchor bolt with a torque wrench set to 150Nm torque. Re tighten the expansion anchors several hours after the initial installation. The anchors should be checked weekly to make sure they are properly affixed.
- **ATTENTION:** Mechanical anchors require a specific installation torque: Failure to apply the recommended installation torque can result in excessive displacement of the anchor under load or premature failure of the anchor. These anchors will lose pre-tension after setting due to pre-load relaxation.
- If anchors **do not tighten to 150Nm** installation torque, replace the concrete under each column base with a **1.2m x 1.2m x 135mm thick 32MPa minimum concrete pad** keyed under and flush with the top of existing floor. Allow concrete to cure before installing lifts and anchors (typically 28 days).

INSTALL THE POWER UNIT

Install the power unit on the Powerside column bracket mount using the four (4) x M8 x 20mm with M8 washers and M8 nylon lock nuts.

Tighten the locking nuts so that the power unit does not move in any direction.

Note. Power Unit can only be fitted to the power column.

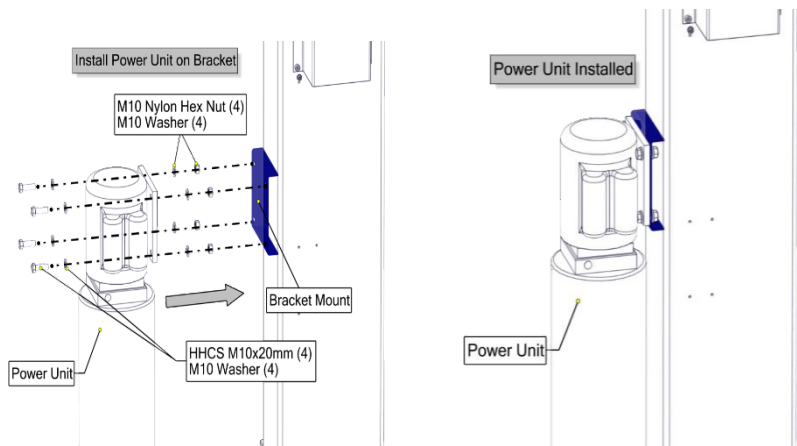

INSTALL THE HYDRAULIC SYSTEM HOSES

The hoist hydraulic system runs a hydraulic line between each hydraulic cylinder, which connects to the Power Unit as shown in the routing image to the right.

There are three (3) hydraulic lines of different lengths. They include.

- 1 x 2890mm (Long)
- 1 x 1040mm (Medium)
- 1 x 360mm (Small)

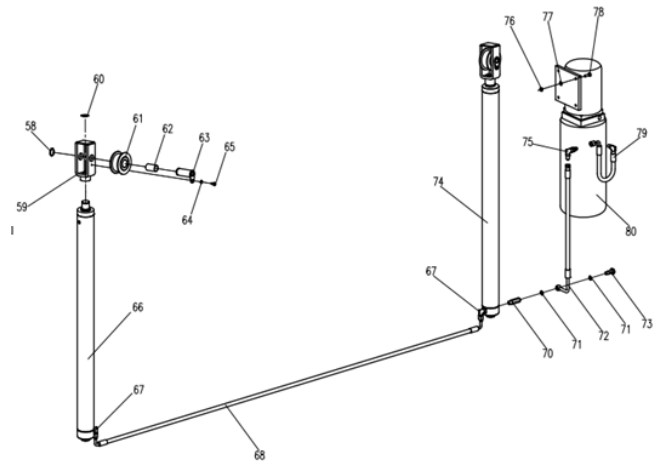

On the non-Powerside connect the long hose end to the **Cylinder Fitting** located at the base of the column.

On the Powerside connect the other end of the long hose to the other cylinder.

On the power unit side connect the 360mm (short hose) to the power unit fitting then connect the other end to the fitting protruding from the power column.

Secure the hoses along the columns and make sure all the connection fittings are tight.

NOTE: do not use Teflon tape with JIS fittings, it will damage the fittings as well as cause failures and oil leakage.

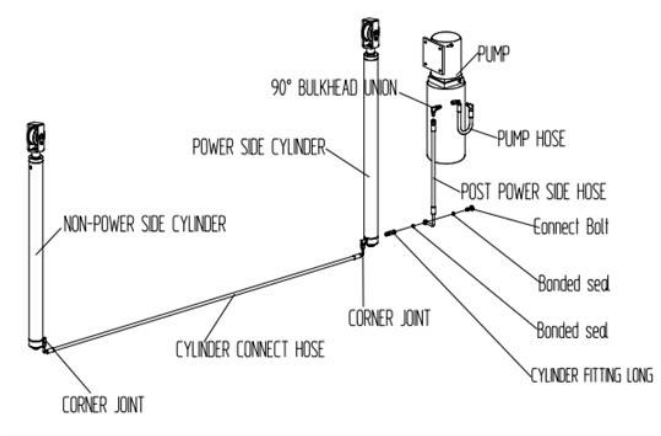

Filling the Power Unit with hydraulic oil.

Remove the oil cap on the power unit and using a funnel fill the reservoir with hydraulic oil.

It is recommended to use a non-foaming, non-detergent hydraulic fluid Ten Weight (Hydraulic Oil ISO AW32 or 46).

The unit will hold approximately **10L**.

NOTE Hydraulic oil must be changed after the first week of operation and then every 12 months or as needed depending on frequency of use.

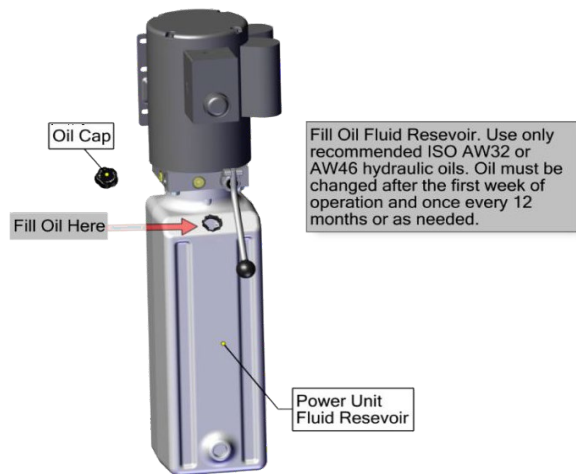

CONNECT ELECTRICAL TO THE POWER UNIT;

 **WARNING:** A certified electrician must install all electrical wiring. Each circuit should have protection with a time delay fuse or circuit breaker. A commercial licensed electrician is recommended to understand the circuitry of the hoist and complete the electrical works.

Minimum requirements required include,

- A 20Amp dedicated circuit with a D curve Breaker.
- An isolator switch mounted close to the hoist location.



WARNING:

Lock Out (disconnect) electrical supply before installing any electrical components or performing maintenance on the lift. Do not ever allow power supply to be connected when working on or repairing lift.

INSTALLING LIFT ARMS

Prior to installing the lifting carriage arms, first test fit the arm pins into the Lifting Carriage Alignment Hole.

The arms pins should rest in the holes easily. If the arm pins are too tight remove a little residual powder coating inside the Lifting Carriage by using a round file to clean the holes. The drop pins should then slide easily and fit snug.

Note: Do not use a grinder or Dremel to clean the hole/s, this could cause an over-sizing of the hole/s which will result in the arm pins not fitting securely and safely.

Now raise both lifting carriages at the same time once power has been turned onto the power unit to assist in installing the arms.

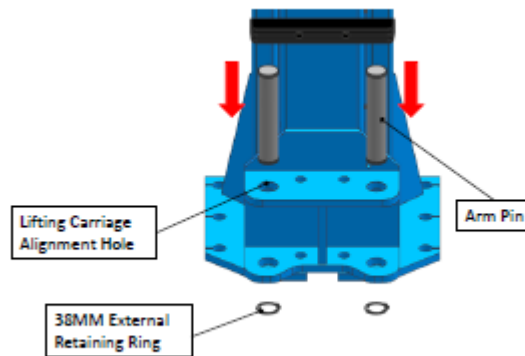

Install the arms by extending them to near full extended length. 3 stage arm will generally go to the front of a vehicle and 2 stage to the rear.

Next place the arm over the holes on the lifting carriage. When centred and aligned with the hole, insert the arm pin. If the fit is tight gently tap the pin using a block of wood and a hammer.

Repeat the same process for each arm until all 4 arms are installed.

Insert Arm Pins into lifting carriage receiver assembly. Pins should rest into holes easily. If it is difficult to install the pins check for residual powder coating that may have not been removed. Use a wire brush to remove excessive powder coat if needed. It is NOT recommended to use a metal hammer to install pins.

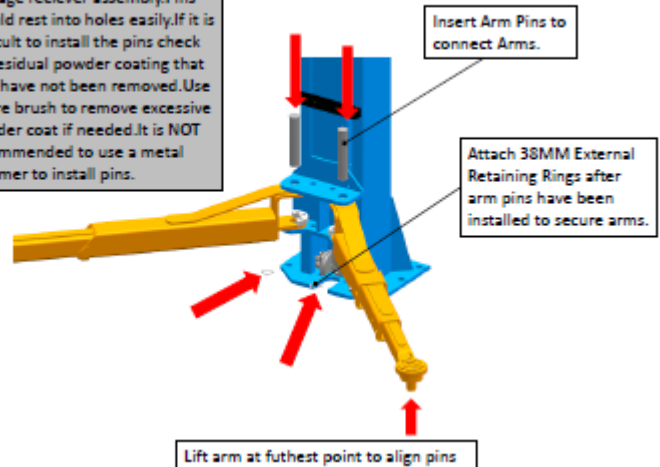

To complete the arm install, raised both lifting carriages to the first lock position.

While in this position attach the 38mm External Retaining Ring on all lift arm drop pins

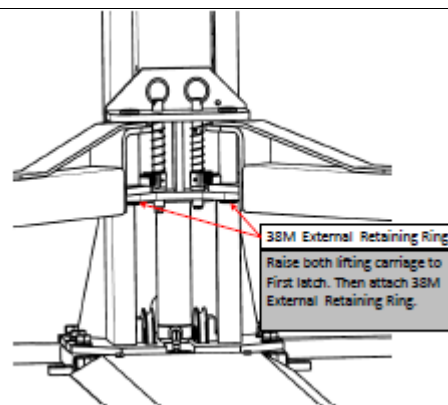

Check the “half-moon” gear restraints on each lifting arm are already installed. Position the lifting arms on the carriages. Check for proper engagement of the arm restraints (arm locks).

The safety gear restraints should fully engage the gear restraints on the arm. After checking that the safety gear restraints and arm gear engage properly. Verify that Allen Bolts on gear restraints are tight and secure

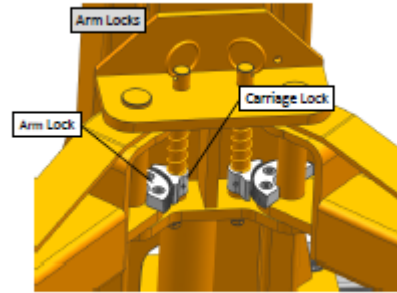

Next attach the Lift Pad to the Lift Arms by inserting the lift pad into the arm receiver hole.

If the arm receiver hole is tight use some sandpaper or light duty file and remove the obstruction by gently rubbing the inside ring.

NOTE: Always check pads for secure contact with vehicle before operating.

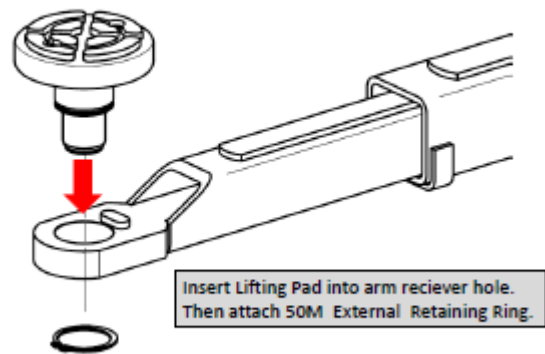

AIR PURGE PROCEDURE

Fold the arms inwards to avoid hitting the power unit.

Raise the hoist to full height and then lower to the ground, keep holding the lowering lever after the hoist has reached the ground for a minimum of 5 seconds. This will aid in releasing any trapped air.

NOTE: If cylinder continues to shake or vibrate when lifted or lowered repeat steps until trapped air is removed from cylinders. (Use a ladder for safety.)

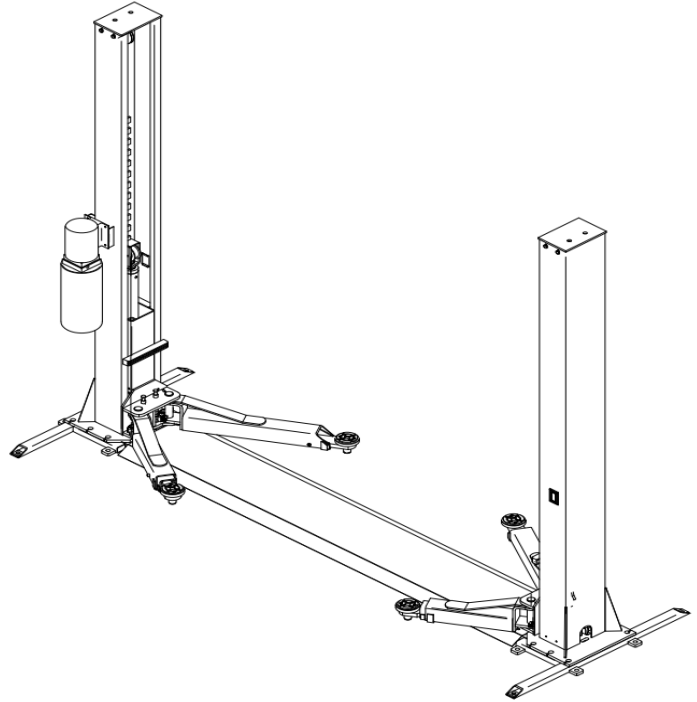

SYNCHRONIZING EQUALIZING CABLES AND LOCKS

With no weight (load) on the hoist, cycle it up and down several times to ensure the safety latches engage properly and all air is removed from the hydraulic system.

To lower the hoist, first raise the hoist to clear the safety latches, then pull on the safety release cables to disengage the locks. This should only require minimal pressure. If the locks are tight and require effort to disengage, re - raise the hoist just enough to clear the safety latch. Pulling the safety release cable should now be effortless.

Re-raise the hoist and LISTEN. You will hear the lock latches begin to hit and release as the hoist is being raised.

After 3 or 4 clicks you will hear the latches synchronizing at the same time. If the safety latches are out of synchronization, you will have to synchronize the equalizing cables on the hoist.

Synchronizing cables

If safety latches are out of sync, adjust the cable on the latch that engages first. To adjust, tighten the **Long Cable End Terminal** on the latch that is engaging first. This could be either the Powerside or Non-Powerside Posts.

The safety lock latches and cables should now be synchronized.

CAUTION

Equalizing Cables Important Notice:

Equalizing Cables must be checked with each daily inspection. The tension should not exceed 25mm of tension slack. Failure to keep cables synchronized could cause an uneven lift which could result in the vehicle falling off the hoist.

Equalizing cables should always be maintained so the safety latches are in sync with the safety locks. Always check that both safety latches are engaging on the appropriate latch.

Lubricate the four inside corners of the columns with heavy duty bearing grease

The last task is to complete **the Post Installation Procedure**.

POST INSTALLATION PROCEDURE:

✓ Check boxes to verify work has been completed.

	Verify columns are properly shimmed and plumb
	Check that expansion anchors are tightened to 150Nm. torque
	Roll pins / sheave pins / hardware / fasteners properly attached and torqued
	Lifting carriage gear restraints securely fastened
	Electrically wired by a professional technician
	Equalizing cables and safety latches in synchronization
	Safety latches functioning properly
	Check for “no” hydraulic leaks
	Oil level full
	All components functioning properly
	All integral moving parts lubricated
	Check for overhead obstructions
	Lifting arms level and on the correct side in relation to the power unit.
	All hardware secure (nuts, bolts, pins)
	Working area clean
	Operation, maintenance and safety manuals in designated location



Operation Manual

JGG-40SF

2 POST Baseplate HOIST

OPERATOR TRAINING AND SAFE PRACTICES.

Keep a copy of these instructions close by and stored in a protected dry location readily available for operators. Each operator must read and carefully follow all safety instructions. Ensure all operators understand how to operate the product safely and correctly before use. Failure to operate this product as intended may cause injury or death.

Prior to each use, on a regular basis, carefully inspect the product and perform all maintenance as required. Service and maintain the product only with authorized or approved replacement parts; negligence will make the product unsafe for use and may void the warranty.

Keep and maintain that all decals on the product remain clean and visible. Do not modify and/or use this product for any application other than that for which this product was designed. If you have any questions related to a particular application contrary to the product's specific functions, **DO NOT** use the product until you have first contacted **Joel's Garage Gear** to determine if it can be performed using the product.

GENERAL SAFETY RULES



WARNING: Read and understand all instructions. Failure to follow all instructions listed below may result in serious injury or death.



WARNING: The warnings, cautions, and instructions discussed in this instruction manual cannot cover all possible conditions or situations that could occur. It is understood and agreed by the operator that common sense and caution are factors that cannot be built into this product. It is the operator's responsibility to adhere to the instructions and operating procedures described in this manual to successfully operate this product.

IMPORTANT SAFETY CONSIDERATIONS

To maintain the product and user safety, you must: -.

- Always check for damaged or worn-out parts before using the hoist. Broken parts will affect the equipment operation. Replace or repair damaged or worn parts immediately.
- Not modify the product in any way. Unauthorized modification may impair the function and/or safety and could affect the life of the equipment.
- Keep instructions readily available for equipment operators.
- Make certain all operators understand how to operate the unit safely and correctly.
- Allow unit operation only with all parts in place and operating properly.
- Use only genuine replacement parts.
- Service and maintain the unit only with authorized or approved replacement parts; negligence will make the product unsafe for use and void the warranty.
- Carefully inspect the unit on a regular basis and perform all maintenance as required.
- Keep all decals on the unit clean and visible.

HAZARD DESCRIPTIONS

Identify the hazard levels used in this manual with the following definitions and signal words:

 **DANGER:**

Immediate hazards which will result in severe liability or exposure to personal injury or death.

 **WARNING:**

Hazards or unsafe practices which could result in severe personal injury or death.

 **CAUTION:**

Hazards or unsafe practices which may result in personal injury, product or property damage

SAFETY MARKINGS

Pay close attention and follow all the safety markings.

- Do not exceed rated capacity.
- Do not move or dolly the vehicle while on the hoist.
- Lift only on areas of any vehicle as specified by the vehicle manufacturer.
- No alterations shall be made to this product.
- Only attachments and/or adapters supplied by the manufacturer shall be used.
- Do not get under or allow anyone under the vehicle until it has been supported with an auxiliary jack stands on both the front and rear of the vehicle.
- Center load on lifting arms and saddles prior to lifting.
- Secure vehicle to ensure no shifting, movement, or tipping will occur when performing maintenance on any vehicle.
- Verify that safety locks are engaged on the arms and lifting carriages before performing any work.
- Do not use this product for any use other than the manufacturer specified usage. Failure to heed these warnings may result in personal injury and/or property damage.



WARNING:

DO NOT USE wooden blocks or any other non-approved load sustaining devices or any other non-approved lifting devices for a means of lifting a vehicle or load being raised. The manufacturer only warrants loads to be sustained by adapters or accessories validated by the manufacturer. Failure to heed these warnings may cause injury or death.



GENERAL OPERATOR SAFETY INSTRUCTIONS:

TRAINING

Do not allow anyone who has not read this operating manual, and/or does not understand the requirements to use the product.

BYSTANDERS

Keep all bystanders away from hoist when in use. Do not allow bystanders under the load supported. Do not allow anyone within a vehicle while the hoist is in use or is supporting a load.

OPERATORS

Not for use by children or people with reduced mental capacity. Do not use under the influence of any drugs or alcohol.

INSPECTION

Inspect the product carefully before each use. Ensure the product is not damaged, excessively worn, or missing parts. Do not use the hoist unless it is properly lubricated. Using a hoist that is not in good clean working condition or properly lubricated may cause serious injury.

INTENDED USE

This two-post car hoist is designed to lift and raise light duty vehicles up to 5000kgs. Our 2 post car hoists offer variable lifting configurations, for unobstructed floor space while repairing vehicles.

GENERAL OPERATION

USE THE HOIST CORRECTLY AND IN A PROPER MANNER. Never use lifting adapters other than what has been supplied by the manufacturer.

- Positioning the vehicle is very important. Only people trained in operating the hoist should position the vehicle on the hoist. Never allow anyone to stand in the path of the vehicle as it is being positioned.
- Some vehicle maintenance and repair activities may cause the vehicle to shift. Follow the manufacturer's guidelines when performing these operations.
- The use of jack stands, or alternate lifting points may be required when completing some repairs for additional security. Special care must be used when lifting light duty trucks. Optional truck adapters may be required for each manufacturer's recommended lifting points.
- Always use these lifting points – (see lifting point guidelines). Running boards and other installed accessories may also require optional adapters.
- Ensure vehicle is balanced, failure to do so can cause injury and/or death.
- Removal or installation of heavier parts can change the vehicle's center of gravity on the hoist resulting in a critical load shift. The vehicle may then be unstable. Plan for this possibility to ensure continued safety and **always** refer to the vehicle manufacturers' service manual for recommended procedures.
- Do not allow customers/friends/children or unauthorized personnel to operate the hoist or remain in the surrounding area during use
- **DO NOT** remove any heavy component from vehicle that may cause excessive weight shift.
- **ALWAYS** keep the hoist area free of obstructions and debris.
- **NEVER** raise a vehicle with passengers inside.
- Before **lowering a vehicle**, check the hoist and surrounding area and remove all obstructions.
- Before removing the vehicle from the hoist, position arms to the drive through position and confirm an unobstructed exit.
- **ALWAYS** Make sure the vehicle's center of gravity is always safe before raising the vehicle. All points of contact on vehicles should always be double checked. Always make sure the vehicle is secure before lifting using vehicle manufacturers' recommended lifting points.
- Large vehicles, such as limousines, RVs, and long wheelbase vehicles, may not be suitable for lifting on this equipment. Check with the vehicle manufacturer.
- **DO NOT** rock or shake the vehicle while on working on or around hoist.
- **VERIFY** that all safety latches are engaged and lowered on to the safety latch ladders before any attempt is made to work on or near vehicle.
- **NEVER** override self-operating hoist controls.
- **NEVER** remove any safety related components, parts or safety stickers from the hoist. Do not use the hoist if any safety related component or part is damaged or missing.
- **DO NOT** block open or override self-closing the hoist controls; they are designed to return to the "Off" or Neutral position when released.
- **DO NOT** remove or disable arm restraints.
- **DO NOT** hit or run over the hoist arms or adapters. This could damage the hoist or vehicle. Before driving the vehicle into hoist bay, position arms and adapters to provide unobstructed entrance onto

the hoist.

- **USE THE HOIST ONLY AS DESCRIBED IN THIS MANUAL.**
- Use only manufacturer's recommended attachments.
- The troubleshooting and maintenance procedures described in this manual can be done by the hoist's owner. Any other procedure should only be performed by trained hoist service personnel. These restricted procedures include, but are not limited to, the following: **cylinder replacement, carriage and safety latch replacement, arm replacement, overhead structure replacement, or electrical troubleshooting/repair.**
- **PAY ATTENTION** when walking under a vehicle that is raised on the vehicle hoist.



DANGERS:

- To reduce the risk of personal injury, keep hair, loose clothing, fingers, and all body parts away from moving parts.
- This equipment has internal arcing or sparking parts. To reduce the risk of electric shock the motor and hoist should not be exposed to moisture or water.
- To reduce the risk of fire, do not operate equipment in the proximity of open containers containing flammable liquids (example: Gasoline, flammable solvents).
- Anyone who will be in the vicinity of the hoist when it is in use should familiarize themselves with all the **Caution, Warning, and Safety** related decals supplied with this hoist and replace them if they are illegible or missing.

SAFETY STICKER IDENTIFICATION

Below are the Safety Sticker identifications and markings that are on the hoist. These identifications are put in place to help with your safety and the safety of others. Always use caution when working around the vehicle hoist.

Please maintain these Safety Marking so safe operating practices can be maintained by each operator.

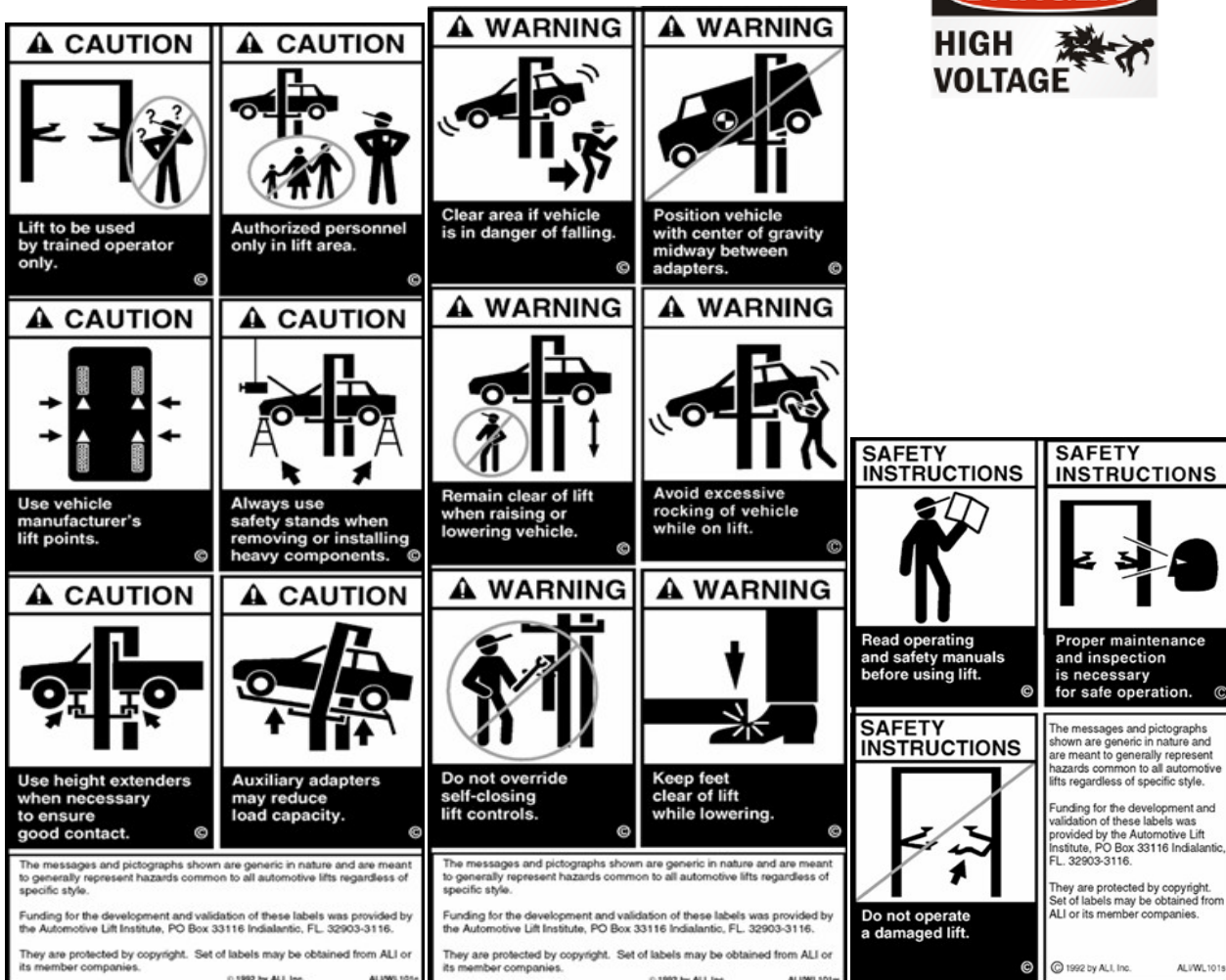
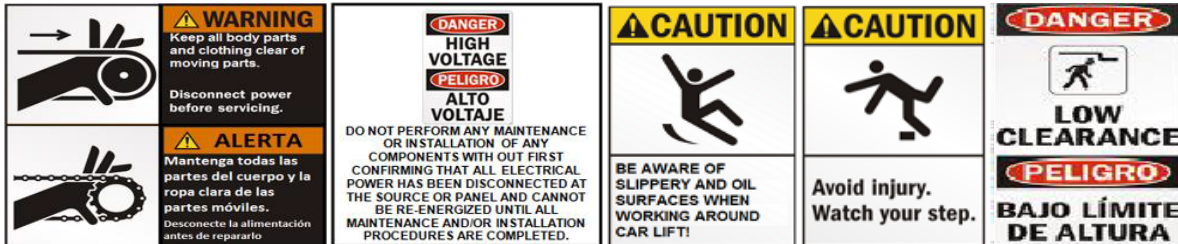

HOW TO OPERATE THE HOIST

- **ONLY AUTHORISED PERSONNEL** should operate the hoist.
- Make sure all operators have been trained and have reviewed the **OPERATOR AND SAFE PRACTICES** of this manual before using the hoist.
- Familiarize yourself with the **Safety Precautions** to be followed when operating this hoist.
- Always allow a minimum 2-second delay between motor starts. Failure to comply may cause the switch and/or motor to burn out. This could cause serious damage to the equipment and/or personal property.
- Use only recommended ISO AW32 or AW46 hydraulic oils. Oil must be changed after the first week of operation and once every 12 months or as needed. Add extra oil as needed.
- Have a complete understanding of the carriage safety lock mechanisms.
 - The **“LOCKED position”** will be used when raising the hoist. This function should always work automatically.
 - The **“UN-LOCKED position”** will be used when lowering the hoist to the ground or adjusting the arm position.
- **Note: DO NOT** remove or tamper with the design of the locking assembly.
- *Failure to use locks as designed or forcing a lock to stay in the open position during use will be grounds for immediate termination of any warranty.*
- **ALWAYS** ensure the safety is engaged before any attempt is made to work under, on or near the vehicle.
- **NEVER** leave the hoist in elevated position unless the safeties are engaged.
- **NEVER** operate the hoist (up or down) with any person or equipment below the vehicle.
- **NEVER** exceed the rated lifting capacity.
- **DO NOT ALLOW THE ELECTRIC MOTOR TO GET WET!** Motor damage caused by dampness is not covered under warranty.
- **NEVER** lift any vehicle in any manner with less than all four (4) arms. The rated capacity of each lifting arm is no greater than one fourth (1/4) of the overall lifting capacity.
- **ALWAYS** position lifting arms, adapters and accessories properly out of the way before pulling the vehicle into or out of the bay. Failure to do so could damage the vehicle and/or the hoist.
- After positioning the vehicle, set the emergency brake (Hand Brake), make sure the ignition is off, the doors are closed, and overhead obstructions are cleared.
- Make sure the vehicle is not front or rear heavy. The center of balance should be in the middle of the columns.

DANGER:

DO NOT RAISE OR LOWER ANY VEHICLE UNLESS TOOLS, MATERIALS AND PEOPLE ARE CLEAR.

CLEAN UP GREASE AND OIL SPILLS IMMEDIATELY. When the hoist is being lowered, make sure everyone is standing at least six feet away. Always lower the vehicle down when the area is safe and clear.

DANGER:

Check that the “half-moon” gear restraints on each lifting arm are engaged. Check for proper engagement of the arm restraints (arm locks) before raising a vehicle. The safety gear restraints should fully engage the gear restraints on the arm automatically. **Note:** Regularly verify that Allen Bolts on gear restraints are tight and secure.

IMPORTANT NOTE:

Many specialty or modified vehicles cannot be raised on a two-post frame engaging hoist. Contact YOUR vehicle manufacturer for raising or jacking details.

ALWAYS load vehicle on hoist carefully. Position the lifting arms, adapters, and pads to the vehicle manufacturer’s recommended pickup points. Raise the hoist until contact is made with the vehicle. Make sure that the lifting arms, adapters, and pads have properly engaged the vehicle before raising the hoist to a working height.

DESCRIPTION OF LIFT CONTROLS

Description:	Purpose:
Safety Release Pull Cord	Used to release safety latches when lowering vehicle.
Power “ON” Button	Controls electrical power to the hydraulic power unit. Push to turn-on.
Lowering Handle	Used to relieve hydraulic pressure when pressed to lower lifting carriages.
Fill Cap	Power unit fill Cap for the power unit fluid reservoir. Remove to add fluid.
Tank	Used to store hydraulic fluid.

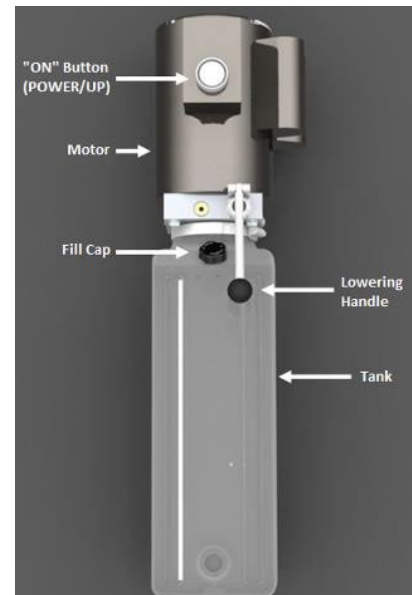

CARRIAGE LOCK CONTROLS

Following the review of these instructions, practice using the lift controls by running the lift through a few unloaded cycles prior to loading a vehicle onto the hoist. Always use all four [4] arms and adaptors when raising or lowering a vehicle. **NEVER RAISE ONE END ONE CORNER OR ONE SIDE OF A VEHICLE.**

LOADING A VEHICLE ON THE HOIST

IMPORTANT NOTE: Some vehicles may have the manufacturer's Service Garage Lifting Point locations identified by triangle shape marks on the undercarriage (reference ANSI/SAE J2184-1992). Additionally, there may be a label located on the right (driver side) front door jamb area showing specific vehicle lifting points.

PRIOR TO LIFTING: The hoist must be fully lowered, and the service bay clean of all personnel and equipment before the vehicle is brought on the lift. The swing arms must be set to the full drive through position.

LOADING: Move vehicle into the hoist bay. Swing arms under vehicle and position adaptors at the vehicle manufactures recommended lifting points – see diagrams. Use height extenders or optional frame cradle adaptors when necessary to ensure good contact.

To load the vehicle onto the hoist, use all four [4] arms making sure the vehicle is positioned correctly so all four corners of vehicle are stationary with wheel stops.

Position all lifting pads to contact vehicle at the manufacturers' recommended lifting points for proper weight distribution.

Raise the arms to just below the vehicle, stopping before making contact. Check arm restraint pin for engagement. If required slightly move the arm to allow restraint gear to mesh. Do not hammer arm restraint pin down as this will damage the restraint gear teeth.

Raise the hoist slowly until all pads contact the vehicle. Check all pads for complete and secure contact with the vehicle. Check all arm restraints to insure they are engaged properly. Check that the vehicle is stable on the hoist.

Raise the vehicle until the tires clear the floor. Stop and again check all adaptors for secure contact at the vehicle manufactures recommended lift points.

DO not go near or under a raised vehicle if all 4 adaptors are not in secure contact with the vehicle at the vehicle manufacturer's recommended lift points. Repeat the entire loading and raising procedure again.

Only after confirming these procedures, raise the hoist to desired working height.

MANY SPECIALTY OR MODIFIED VEHICLES CANNOT BE RAISED ON A TWO-POST FRAME ENGAGING LIFT. CONTACT VEHICLE MANUFACTURER FOR RAISING OR JACKING DETAILS

RECOMMENDED LIFTING POINTS

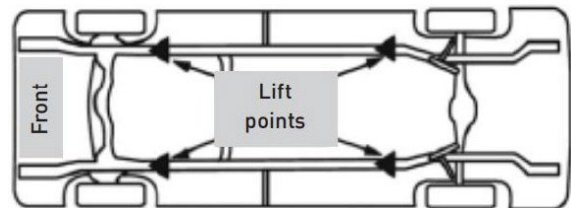

Pick up truck / Van

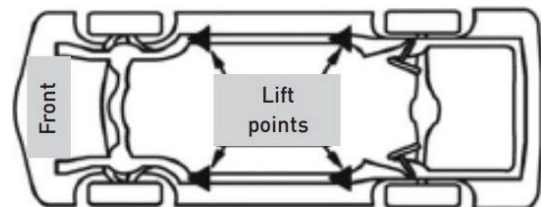

Perimeter Frame

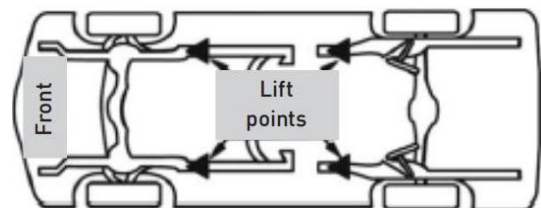

Stub frame

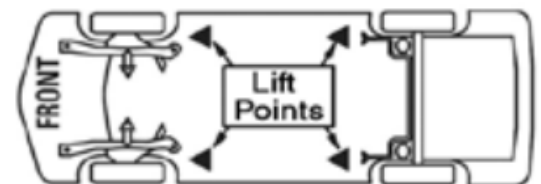

Unitized Body

RAISING THE HOIST WITH VEHICLE LOAD,

- Prior to raising any vehicle, ensure the vehicle's is positioned at best to its center of gravity. Double check that all points of the lifting pads have contact on the vehicle. Always make sure the vehicle is secure before lifting using only your vehicle manufacturers' recommended lifting points.
- Adjust the lifting arms so that the vehicle is positioned with the center of gravity midway between the hoist columns. (Use truck adapters as needed.)
-  **DANGER: NEVER** use the lifting pad assemblies without the rubber pads in place.
- Press the power "on" button.
- As the hoist rises a clicking sound will be heard. These are the carriage locks that will securely hold a vehicle.
- Once the desired height has been achieved slightly raise the carriage a little more, so the lift arms are just above the last latch position, (confirmed by the clicking sound) then slowly lower the load on the safety locks.
- **NEVER** attempt to raise or 'creep' the hoist by continually pressing the 'on' button in short bursts. This will cause critical damage to the hydraulic system, that could cause hydraulic failure.
- Verify that both Safety Carriage locks have been engaged before beginning work.

LOWERING THE HOIST WITH VEHICLE LOAD

- Prior to lowering the hoist
 - Always remove tool trays, stands and any other equipment that may cause obstruction.
 - Always release safety locks before attempting to lower the hoist.
 - Always position the hoist arms and adapters to provide an unobstructed exit before removing the vehicle from the area.
- To lower the hoist, first raise the hoist to clear the safety latches, press the power "on" button, then pull down the safety release pull cords. The carriages should now be in the free UN- LOCKED position.
- Press the lowering control valve on the power unit.
- Lower the hoist slowly until reach the lowest retracted position.
- Retract the lifting arms to the shortest position.
- Place any arm extension adapters on column storage brackets.

WHEN LOWERING THE LIFT PAY CAREFUL ATENTION THAT ALL PERSONNEL AND OBJECTS ARE KEPT CLEAR.

ALWAYS KEEP A VISUAL LINE OF SITE ON THE LIFT AT ALL TIMES. ALWAYS MAKE SURE THAT ALL LOCKS ARE DISENGAGED. IF ONE OF THE LOCKS INADVERTENTLY LOCKS ON DESCENT THE LIFT AND/OR VEHICLE MAY DISRUPT CAUSING PERSONAL INJURY OR DEATH

WEEKLY MAINTENANCE INSPECTION RECORD DATE: _

Mark OK for all Items in good working order.

	Lubricate posts with grease. Lubricate the four inside corners of the columns with heavy-duty bearing grease as needed.
	Inspect lifting arms making sure they are functioning properly.
	Visually inspect safeties for proper operation. Check all arm adjusting locks for proper operation.
	Inspect all arms pins making sure they are properly secure.
	Inspect that arm pads are in good condition, replace if worn.
	If the hoist is equipped with an overhead stop bar, check for proper operation.
	Check that all posts are square and plumb.
	Check equalizer cable tension, and adjust if necessary, see manual instructions. Lubricate Cable Sheaves.
	Check all cables connections, bolts and pins to ensure proper mounting and torque.
	Check safety latch synchronization: Safety latches should click at the same time. If necessary, adjust equalizing cables as described in the Installation Instruction section of this manual.
	Check tightness of all bolts and hardware. Re-tighten as needed. See installation manual torque specified ratings.
	Inspect all anchors bolts and retighten if necessary. Re-torque as needed. See installation manual for instructions.
	Make a visual inspection of all moving parts and check for excessive signs of wear.
	With the hoist in the lowered position, check the hydraulic fluid level. If needed, add oil as described in the Installation Instruction section of this manual.
	Check all warning labels and power unit safety stickers are in good condition. Replace all caution, warning or safety related decals on the lift if unable to read or missing. Reorder labels from manufacturer.



NOTES: _____

PRINT COPY PAGES FOR DAILY RECORDS

WIRE ROPE INSPECTION MAINTENANCE



Know when to replace your cables! The pictures below will help you assess when you will need to replace wire rope. For Additional Information see "Wire Rope User's Manual 4th Ed."

All wire rope, sheaves and guide rollers in continuous service should be observed during normal operation and visually as per the scheduled maintenance. A complete and thorough inspection of all ropes in use must be made as below and all rope which has been idle for a period of a month or more should be given a thorough inspection before it is put back into service. Factors such as abrasion, wear, fatigue, corrosion, improper winding and kinking are often of greater significance in determining if a wire rope is usable. Use the pictures as shown as guide for determining when to replace your wire rope.

Recommended Lubrication Product:

A high grade penetrating lubricant for wire rope, chain and cable that contain a petroleum solvent that carry the lubricant into the core of the wire rope, then evaporates, leaving behind a heavy lubricating film to protect and lubricate each strand. A penetrating lubricant is essential in any lubrication program as most wire rope fails from the inside out.

Check all guide rollers, sheaves and hardware that are in operational contact are visually checked for wear and lubrication

HOW TO INSPECT WIRE ROPE?

- I. Relax the rope to a stationary position and move the pick-up points off the sheaves. Clean the surface of the rope with a cloth this will allow you to see breaks. (Use a stiff wire brush, if necessary.)
- II. Flex the rope to expose any broken wires hidden in the channels between the strands.
- III. Visually check for any broken wires. One way to check for crown breaks is to run a cloth along the rope to check for possible snags.
- IV. With an awl tool, probe between wires and strands and lift any wires that appear loose. Evidence of internal broken wires may require a more extensive rope examination. **(IF IN DOUBT REPLACE CABLES)**
- V. Check for layer to layer crushing or individual wires that may have been displaced from their normal position.
- VI. Check Sheaves for deeply corrugated sheaves that may also be causing damage to wire ropes. Replace sheaves if needed.

- VII. Replace wire rope if any failing condition is found.
 - ✓ Equalizing and Lifting Cables should be replaced every three years when visible signs of damage are apparent. **DO NOT USE THE HOIST WITH DAMAGED OR WORN CABLES.**
 - ✓ A lubricant suited to the conditions under which the rope is operating should then be applied. Several methods are suggested, and the one most suited to the installation and lubricant being used may be chosen. It is better to lubricate lightly and frequently than heavily and infrequently. For best results lubricate to core of cables.
 - ✓ **Improve rope performance and overall effectiveness**
 - ✓ **Check all guide rollers, sheaves and hardware that are in operational contact are visually checked for wear and lubrication.**
 - ✓ **Visually Inspect and Apply lubricants to all contact points using a heavy weight lubricant using the methods as described: spray, pump, brush or hand lubrication.**

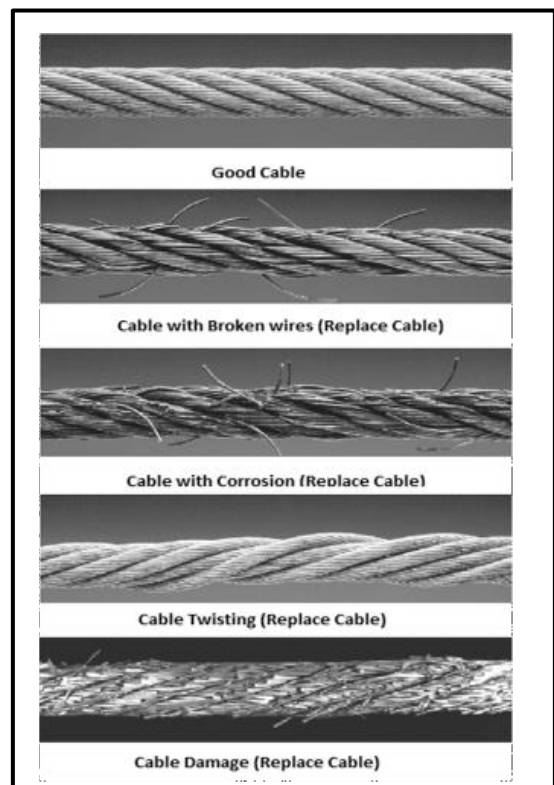

TROUBLESHOOTING

HOIST WILL NOT RAISE

	Air is in the oil	<ul style="list-style-type: none"> • Check for proper oil level. The oil level should be up to the bleed screw in the reservoir with the hoist all the way down. • Bleed cylinders. See Installation Manual • Oil seal damaged or cocked. Replace oil seal around pump shaft. • Inlet screen clogged. Clean inlet screen or replace
	Cylinder is binding	<ul style="list-style-type: none"> • Contact Customer Service.
	Cylinder leaks internally	<ul style="list-style-type: none"> • Contact Customer Service
	Hoist does not raise and lower smoothly	<ul style="list-style-type: none"> • Reposition vehicle for a more even weight distribution. • Check the four inside corners of the two columns for roughness. Any rust or burrs must be removed with emery cloth. • Lubricate the four corners with heavy duty bearing grease. • Use a level to check the columns for vertical alignment both side to side and front to back. Shim the columns as necessary per the Installation Instruction section of this manual. • Check the oil level. • Inspect that there is no air in the hydraulic lines. Bleed the hydraulic system as described in the Installation Instruction section of this manual.
	Lowering valve is leaking	<ul style="list-style-type: none"> • Contact Customer Service
	Motor runs backwards	<ul style="list-style-type: none"> • Check if the motor is wired correctly. Compare wiring of motor to electrical diagram on drawing. • Check wall outlet voltages and wiring. Make sure the unit and wall outlet are wired properly. • Contact Customer Service
	Motor run backward under pressure	<ul style="list-style-type: none"> • Contact Customer Service
	Power Unit will not stop running	<ul style="list-style-type: none"> • The switch is damaged. Turn off power to the hoist and replace switch
	Pump is damaged	<ul style="list-style-type: none"> • Contact Customer Service
	Pump will not prime	<ul style="list-style-type: none"> • Check for proper oil level. The oil level should be up to the bleed screw in the reservoir with the hoist all the way down. • Flush release valve incase jammed open. Hold release handle down and start unit allowing possible contamination to be flushed out, run for 15 seconds. • Oil seal damaged or cocked. Replace oil seal around pump shaft. • Replace with new part. • Check pump-mounting bolts. Bolts should be 15 to 18 ft. lbs. • Inlet screen clogged. Clean inlet screen or replace. • Check wall outlet voltages and wiring. Make sure the unit and wall outlet are wired properly. • Contact Customer Service
	Relief valve leaks	<ul style="list-style-type: none"> • Contact Customer Service
	Voltage to the motor is incorrect	<ul style="list-style-type: none"> • Check if the motor is wired correctly. Compare wiring of motor to electrical diagram on drawing. • Check wall outlet voltages and wiring. Make sure the unit and wall outlet are wired properly. • Contact Customer Service.
	The power unit does not run	<ul style="list-style-type: none"> • Check electrical supply breaker or fuse. • Check to see if limit switch is being contacted by a tall vehicle. • Check micro-switch and connections in motor control box. • Check voltage to the motor. • Check micro-switch and connections on the overhead switch.
	The power unit runs but does not raise the hoist	<ul style="list-style-type: none"> • Check the oil level. • Check that the lowering valve is not stuck open. • Check the connections and components on the suction side of the pump.
	The power unit raises the hoist empty but will not lift a vehicle	<ul style="list-style-type: none"> • Make sure the vehicle is not above the rated capacity of the hoist. • Make sure the vehicle is positioned properly. • Clean the lowering valve by running the power unit for 15 seconds while holding the lowering valve open. • Check the motor voltage.

TROUBLESHOOTING

MOTOR WILL NOT RUN

	Fuse is blown	<ul style="list-style-type: none"> • Check for correct voltage. Compare supply voltage with voltage on motor name tag. Check that the wire is sized correctly. Requires 2.5mm² for 20 Amps. • Check the motor is wired correctly. Compare wiring of motor to electrical diagram on drawing. • Don't use extension cords. The size of the conductors should be such that the voltage drop would not exceed 3% to the farthest outlet for power. • Reset circuit breaker/fuse. Reset circuit breaker/fuse. • Contact Customer Service.
	Limit switch is burned out	<ul style="list-style-type: none"> • Check for correct voltage. Compare supply voltage with voltage on motor name tag. Check that the wire is sized correctly. Requires 2.5mm² for 20 Amps. • Check the motor is wired correctly. Compare wiring of motor to electrical diagram on drawing. • Don't use extension cords. The size of the conductors should be such that the voltage drop would not exceed 3% to the farthest outlet for power. • Contact Customer Service.
	switch is burned out	<ul style="list-style-type: none"> • Check for correct voltage. Compare supply voltage with voltage on motor name tag. Check that the wire is sized correctly. Requires 2.5mm² for 20 Amps. • Check the motor is wired correctly. Compare wiring of motor to electrical diagram on drawing. • Don't use extension cords. The size of the conductors should be such that the voltage drop would not exceed 3% to the farthest outlet for power. • Contact Customer Service.
	Motor is burned out	<ul style="list-style-type: none"> • Check for correct voltage. Compare supply voltage with voltage on motor name tag. Check that the wire is sized correctly. Requires 2.5mm² for 20 Amps. • Check the motor is wired correctly. Compare wiring of motor to electrical diagram on drawing. • Don't use extension cords. The size of the conductors should be such that the voltage drop would not exceed 3% to the farthest outlet for power. • Replace with a new part. • Contact Customer Service
	Voltage to the motor is not correct	<ul style="list-style-type: none"> • Check for correct voltage. Compare supply voltage with voltage on motor name tag. Check that the wire is sized correctly. Requires 2.5mm² for 20 Amps. • Check motor is wired correctly. Compare wiring of motor to electrical diagram on drawing. • Check wall outlet voltage and wiring. Make sure unit and wall outlet is wired properly. Motor must run at 220-240 VAC.

 **DANGER:**

IF A VEHICLE BECOMES STUCK ON THE HOIST IN THE AIR, FOLLOW ALL OPERATION INSTRUCTIONS AS SHOWN IN THE OPERATING INSTRUCTIONS AND TROUBLESHOOTING SECTION OF THIS MANUAL. IF AFTER OBSERVING THAT ALL MECHANICAL LOCKS ARE RELEASED AND THE HOIST STILL FAILS MOVE FOLLOWING ALL STANDARD OPERATING PROCEDURES, IMMEDIATELY STOP USING THE HOIST AND CONTACT CUSTOMER SERVICE FOR FURTHER INSTRUCTIONS.

GENERAL ASSEMBLY DIAGRAM

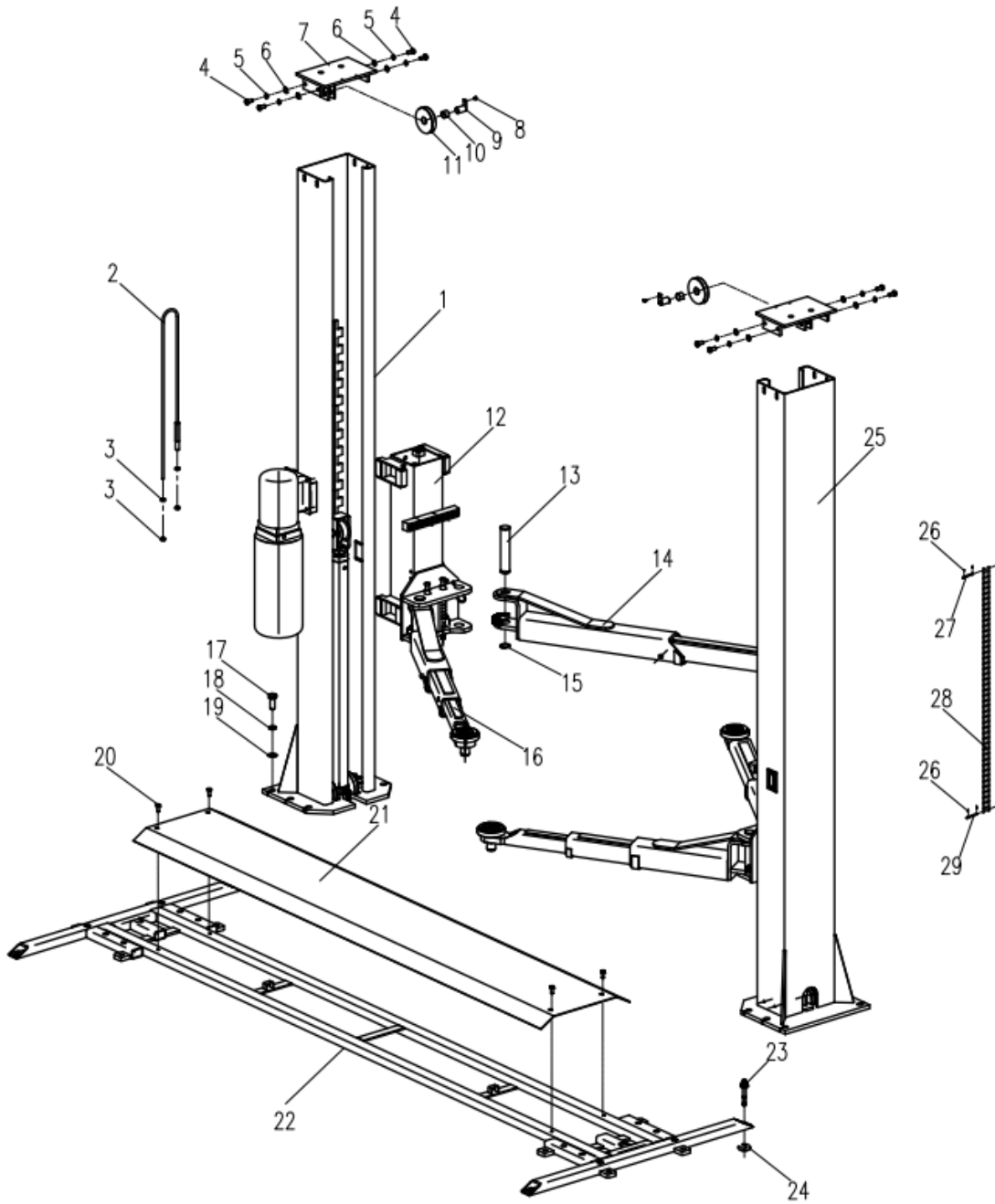

GENERAL ASSEMBLY PARTS LIST

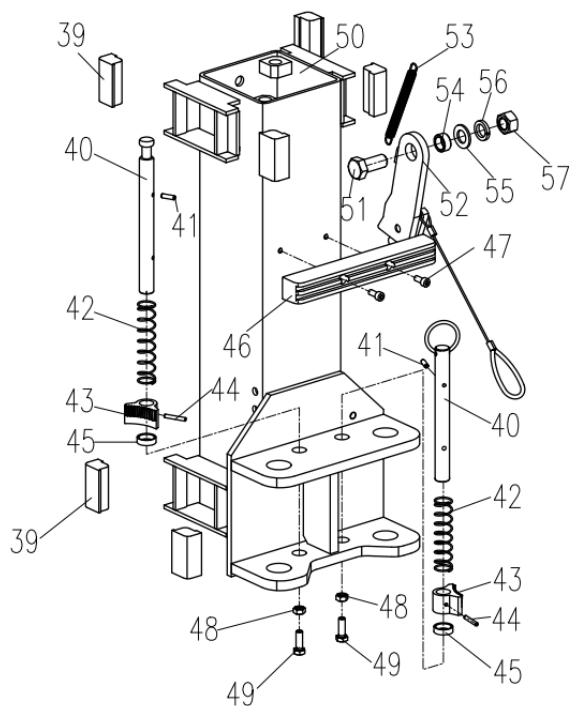
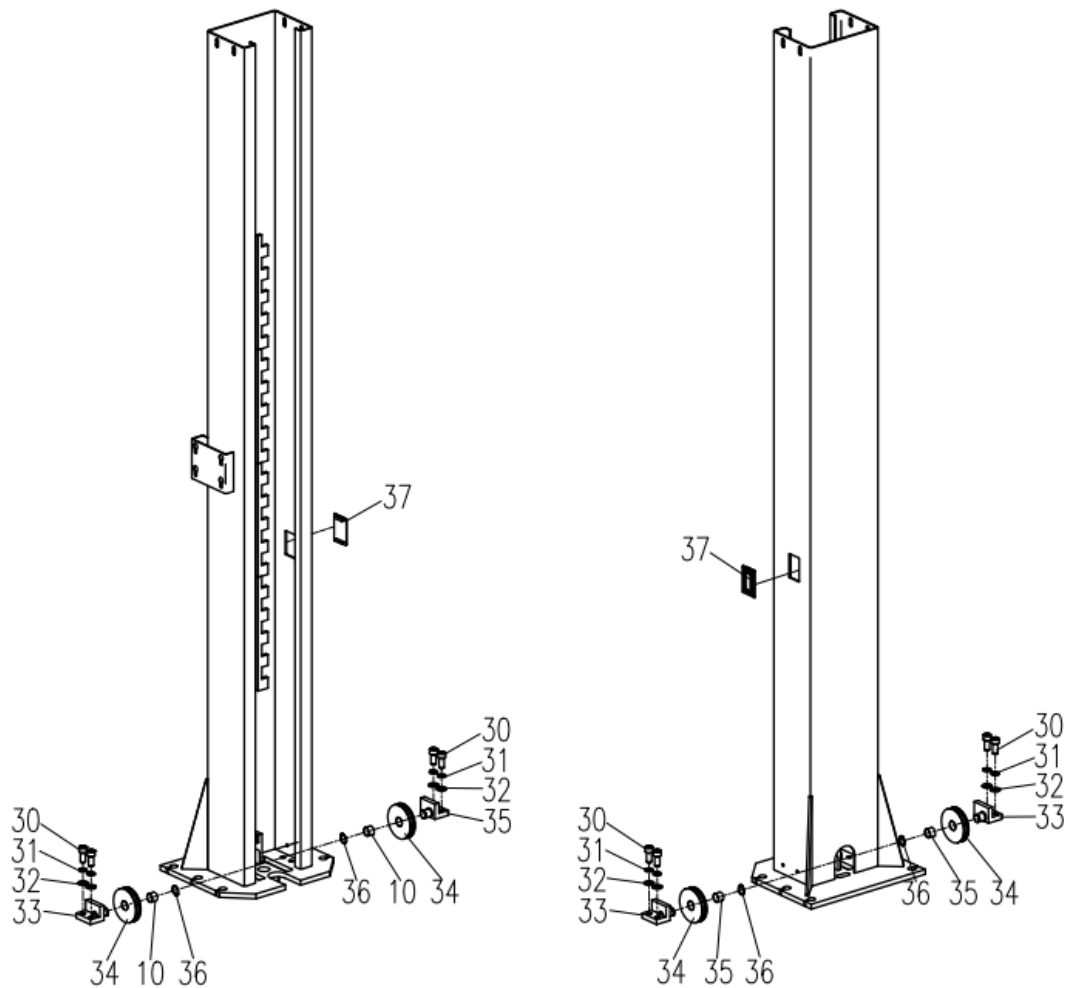

COLUMN ASSEMBLY PARTS LIST

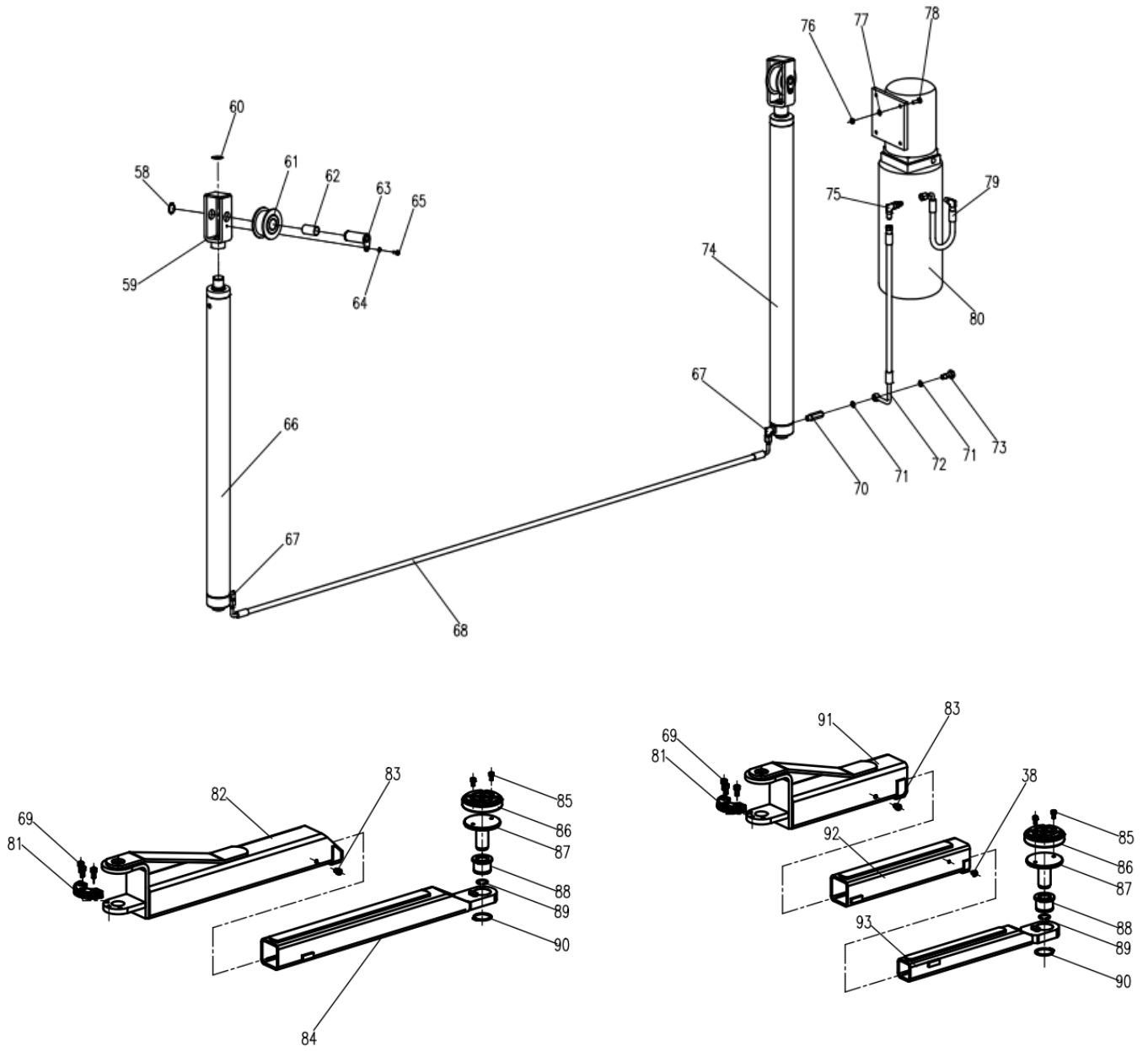

PARTS LIST

item	Part No.	Part name	Remark
46	QJY230CY.2-01a	RUBBER PAD	
47	GB/T 70.1	SOCKET HEAD CAP SCREW M8x20	
48	GB/T 6170	NUT M10	
49	GB/T 5783	HEX HEAD BOLT M10x30	
50	QJY240BC.3	CARRIAGE ASSEMBLY	
51	GB/T 5783	HEX HEAD BOLT M20x40	
52	QJY240CA.3a.2	LNSURANCE COMPONENT	
53	QJY240CA.3-02	LNSURANCE SPRING	
54	QJY230CC.3-01	LNSURANCE RING	
55	GB/T 97.1	FLAT WASHER 20	
56	GB/T 93	SPRING WASHER 20	
57	GB/T 6170	NUT M20	
58	GB/T 894.1	CIRCLIP 30	
59	QJY240CC.8.1	CHAIN WHEEL BRACKET	
60	GB/T 894.1	CIRCLIP 32	
61	QJY235CQ.8-1	CHAIN WHEEL	
62	SF-2	BUSHING 3047	
63	QJY240CC.8.3	CHAIN WHEEL SHAFT	
64	GB/T 93	SPRING WASHER 8	
65	GB/T 5783	HEX HEAD BOLT M8x16	
66	QJY230C.8-04	NON-POWER SIDE CYLINDER	
67	QJY230C.8-02	90° CYLINDER FITTING	
68	QJY240BC-E.8-01	HYDRAULIC HOSE LONG	
69	GB/T 70.1	SOCKET HEAD CAP SCREW M10x20	
70	QJY240BN-E.8-03	CYLINDER FITTING LONG	
71	JB982-77	COMPOSITE WASHER 14	
72	QJY230DY-N.6-02	HYDRAULIC HOSE	
73	QJY240BN-E.8-02	HOSE CONNECTOR	
74	QJY230C.8-07	MAIN CYLINDERS	
75	QJY230C.8-02	90° CYLINDER FITTING	
76	GB/T 889.1	NUT M8	
77	GB/T 97.1	FLAT WASHER 8	
78	GB/T 5783	HEX HEAD BOLT M8x22	
79	QJY240CC.8-02	HYDRAULIC HOSE	
80		POWER UNIT	
81	QJY235CQ.4-01	ARM TEETH BLOCK	
82	QJY240DC.5.2	LONG BACK ARM WELDMENT	
83	GB/T 70.1	SOCKET HEAD CAP SCREW M10x12	
84	QJY240DC.5.1	LONG FRONT ARM WELDMENT	
85	GB/T 70.1	SOCKET HEAD CAP SCREW M8x14	
86	QJY230C.4.3b-04	ROUND LIFTING PAD	
87	QJY245DS.5.3-02	LIFTING TRAY	
88	QJY240CA.4.3-01	INSIDE SWIVEL SHEATH	
89	QJY245DS.5.3-03	CIRCLIP 32	
item	Part No.	Part name	Remark
91	QJY240DC.6.1	CORBEL AFTER THREE PARTS	
92	QJY240DC.6.2	CORBEL IN THREE PARTS	
93	QJY240DC.6.3	CORBEL BEFORE THE THREE PARTS	

Joel's GARAGE GEAR

www.joelsgaragegear.com.au