

**Joel's** GARAGE GEAR

# INSTALLATION GUIDE/ OWNERS MANUAL



# JGG-45CF

4500KG 2 POST CLEAR FLOOR HOIST

## CONTENTS

TECHNICAL SPECIFICATIONS.....	3
CONCRETE FOUNDATION SPECIFICATIONS AND REQUIREMENTS .....	3
OWNER /INSTALLER RESPONSIBILITIES: .....	4
IMPORTANT INFORMATION:.....	4
SHIPPING DAMAGE/MISSING PARTS CLAIMS .....	4
LIMITATION OF LIABILITY .....	4
PRODUCT WARRANTY .....	5
WHAT IS NOT COVERED BY THE PRODUCT WARRANTY .....	5
INSTALLATION TOOLS REQUIRED:.....	6
PRE-INSTALLATION PROCEDURES.....	7
SELECT LIFT LOCATION:.....	7
FLOOR REQUIREMENTS: .....	7
CEILING REQUIREMENTS: .....	7
DEFECTIVE CONCRETE: .....	7
HOIST LOCATION LAYOUT.....	8
LAYOUT THE INSTALLATION AREA. ....	8
IMPORTANT AND GENERAL INFORMATION FOR EXPANSION ANCHORS.....	9
EXPANSION ANCHOR INSTALLATION INSTRUCTIONS 20mm X 140mm .....	10
INSTALLATION PROCEDURE.....	13
UNPACKING THE HOIST .....	13
COLUMN CABLE INSTALLATION .....	13
INSTALL THE SAFETY CABLE BRACKET ON BOTH COLUMNS.....	14
INSTALL THE CROSSOVER BEAM PLATE CONNECTION. ....	15
INSTALLING THE COLUMNS.....	16
DRILLING FOR EXPANSION ANCHORS. ....	16
ASSEMBLE THE OVERHEAD CROSSOVER BEAM.....	17
INSTALL THE OVERHEAD CROSSOVER BEAM. ....	17
INSTALLING EXPANSION ANCHORS AND LEVELING THE COLUMNS.....	18
RUNNING THE EQUALIZER CABLES .....	20
SAFETY LATCHES AND SAFETY CABLE.....	21
INSTALL NON-POWERSIDE SAFETY LATCH SYSTEM.....	21
INSTALL POWERSIDE SAFETY LATCH SYSTEM. ....	22
INSTALL AND ROUTE THE SAFETY CABLE.....	22
INSTALL NON-POWERSIDE SAFETY COVER. ....	24
INSTALL THE POWER SIDE SAFETY COVER. ....	24
INSTALL THE POWER UNIT .....	25

INSTALL THE HYDRAULIC SYSTEM HOSES ..... 25

CONNECT ELECTRICAL TO THE POWER UNIT; ..... 27

INSTALLING LIFT ARMS..... 28

AIR PURGE PROCEDURE ..... 30

SYNCHRONIZING EQUALIZING CABLES AND LOCKS ..... 31

POST INSTALLATION PROCEDURE:..... 32

OPERATION MANUAL ..... 33

OPERATOR TRAINING AND SAFE PRACTICES..... 34

GENERAL SAFETY RULES ..... 34

IMPORTANT SAFETY CONSIDERATIONS..... 34

HAZARD DESCRIPTIONS..... 35

SAFETY MARKINGS ..... 35

    TRAINING ..... 36

    BYSTANDERS ..... 36

    OPERATORS ..... 36

    INSPECTION ..... 36

INTENDED USE..... 36

GENERAL OPERATION ..... 37

SAFETY STICKER IDENTIFICATION..... 39

HOW TO OPERATE THE HOIST..... 40

    IMPORTANT NOTE: ..... 41

DESCRIPTION OF LIFT CONTROLS ..... 42

CARRIAGE LOCK CONTROLS..... 42

LOADING THE HOIST ..... 43

RAISING THE HOIST,..... 44

TO LOWER THE HOIST,..... 44

WEEKLY MAINTENANCE INSPECTION RECORD..... 45

WIRE ROPE INSPECTION MAINTENANCE..... 46

TROUBLESHOOTING ..... 47

TROUBLESHOOTING ..... 48

GENERAL ASSEMBLY DIAGRAM ..... 49

GENERAL ASSEMBLY PARTS LIST ..... 50

## TECHNICAL SPECIFICATIONS

### JOELS GARAGE GEAR-45CF 2 POST CLEAR FLOOR HOIST

Description	Metric (mm) (kg)
Lift Capacity	4500kg
Switch Off Level	3461mm
Max Rise from The Ground- No extension blocks	1910mm
Lifting Range	1755mm
Lifting Pad Minimum Height- No extensions	105mm
Lifting Pad Minimum Height- No extensions	155mm
Drive-Thru Clearance	2658mm
Width Inside of Columns	2980mm
Front Arm Reach	1328mm
Rear Arm Reach	1315mm
Overall, Height (Top of cylinder at full height)	3650mm
Overall Width at base plate	3551mm
Width Arms Open	492 to 1063mm
Width Arms Centered	4275mm
Lift Time	60 Seconds
Concrete thickness and strength	125mm @ 32MPa
N.W / G.W	750kg / 780kg

### CONCRETE FOUNDATION SPECIFICATIONS AND REQUIREMENTS

2-Post Hoist 4500kg. 125mm Min. Thickness / 32MPa. RL1118 Mesh.

Safe Operating Temperature is between 4°C - 41°C.



## **OWNER /INSTALLER RESPONSIBILITIES:**

### **DO NOT PROCEED WITHOUT READING THIS MANUAL**

It is vital that you carefully read and fully understand all **ASSEMBLY INSTRUCTIONS** before installing this product. Failure to follow the safety rules and basic safety precautions described and presented in this manual may result in serious personal injury including death.

If you have any questions or experience problems, please call our Customer Support department on **1800 563 574**, Monday-Friday. 8.30 a.m.- 4.30 p.m. Melbourne Time.

All repairs are only to be performed by authorised or qualified technicians.

By proceeding you acknowledge and agree that you will fully comprehend and understand the contents of this manual.

### **IMPORTANT INFORMATION:**



**WARNING: Do not allow other people to assemble this product until they have read this manual and have developed a thorough understanding of how the product works.**

The **JGG-45CF, 2 Post Clear floor Hoist** is designed for **indoor use only** and should not be installed in a pit or on an uneven surface. The floor on which the hoist is installed must have a **minimum thickness of 125mm concrete** substrate, reinforced with steel bar (RL118 Mesh) with a minimum compressive strength of **32MPa**. (If you are unsure of this requirement, we strongly recommend you contact your builder or architect for information before installing on pre-stressed concrete.)

This hoist has specific electrical and physical height requirements as described in the installation section of this manual. **Failure by the owner to provide and meet the recommended shelter, mounting surface, electrical supply, and ceiling height can result in unsatisfactory hoist performance, property damage, personal injury or both. Failure to comply with these basic requirements will void any warranty on the product.**

### **SHIPPING DAMAGE/MISSING PARTS CLAIMS**

Any freight damage or lost parts (where visible) must be noted on the freight bill before signing off and must be reported to Joel's Garage Gear to establish a freight claim. When unpacking the product carefully check that all components are provided – refer to the complete parts list provided at the end of this manual. If shortages are discovered, please contact Joel's Garage Gear immediately with a missing part/s list.

### **LIMITATION OF LIABILITY**

The **manufacturer and Joel's Garage Gear** are not and will not be held responsible for any liability for loss, damages of any kind expressed or implied, injury, and or damage to your property or otherwise caused by improper installation, use of this product or neglect on your or the operators' actions.

## **PRODUCT WARRANTY**

### **WHAT IS NOT COVERED BY THE PRODUCT WARRANTY**

- Any failure that results from owner/operator abuse, neglect or failure to operate, maintain or service product in accordance with instructions provided in the owner's manual.
- Any damage caused by overloading lift beyond rated capacity.
- General service on a regular basis is required to maintain the product, i.e. lubricants, oil, etc.
- General wear-n-tear of parts such as rubber pads, etc. unless wear or failure is a direct result of manufacturer defect due to material and/or workmanship.
- Any failure caused by installing or operating lift under conditions not in accordance with installation and operation guidelines or damaged by contact with tools or surroundings.
- Motor or pump failure caused by exposure to moisture/water, excessive humidity, corrosive environments or other contaminants.
- Rusted components due to improper maintenance or corrosive environments.
- Cosmetic defects that do not interfere with product functionality, such as scratched paint.
- Damage due to incorrect voltage or improper wiring.
- Any incidental, indirect, or consequential loss, damage or expense that may result from any defect, failure or malfunction of the product.

## INSTALLATION TOOLS REQUIRED:

Please ensure you have all the necessary tools and equipment listed below to successfully complete the installation. **We recommend that you use safety protective clothing and eyewear when installing the hoist.**

- 8m. Measuring tape
- Chalk line and chalk or equivalent
- Heavy duty metal wire cutters
- 900mm Crowbar
- Full set of metric wrenches and ratchet set
- Full set Imperial wrenches and ratchet set
- Full set metric and Imperial Allen keys
- 30mm Socket and Calibrated Torque Wrench
- Hammer
- Rubber mallet
- Phillips screwdriver
- Flat blade screwdrivers
- Circlip pliers.
- 2 x 3m Step ladders
- 1m. Spirit Level
- Rotary hammer drill
- 20mm diameter masonry drill bit
- Lifting devices such as a crane or forklift\*
- 100mm x 100mm wooden blocks (use for unpacking)
- Gloves
- \*Additional help if no lifting devices available

## PRE-INSTALLATION PROCEDURES

Before installation, check and confirm the following:

### SELECT LIFT LOCATION:

Always use architects building plans when available. Check layout dimensions against floor plan requirements making sure that adequate space is available on both the sides and in height.

### FLOOR REQUIREMENTS:

The hoist should be located on a level floor with less than **3 degrees' slope**. If unsure, consider a survey of the proposed location and/or the possibility of pouring a new level concrete slab. This hoist can only be installed on a concrete floor which conforms to the specifications detailed in this manual. Columns are supported only by anchoring to concrete floors. Failure to do so could cause personal injury or death. **DO NOT INSTALL** the hoist on asphalt. **DO NOT** locate this machine in a recessed area or below floor level. **ALLOW FOR PROPER DRAINAGE.**

### CEILING REQUIREMENTS:

The area where the hoist will be located should be free of overhead obstructions such as heaters, building supports, electrical lines, etc.

### DEFECTIVE CONCRETE:

Visually inspect the site where the hoist will be installed and check for cracked or defective concrete. If the proposed location is in question, **DO NOT INSTALL THIS HOIST**. If you have any questions and concerns with the hoist location selected contact your local builder or architect. (*Note - A qualified person should be consulted to address seismic loads and other local or state requirements*)

**JOEL'S GARAGE GEAR WILL NOT BE HELD RESPONSIBLE OR LIABLE FOR ANY CONCRETE THAT MAY OR MAY NOT MEET SLOPE REQUIREMENTS. IT IS COMPLETELY THE OWNER'S RESPONSIBILITY TO ENSURE THAT THE CORRECT SUBSTRATE FLOORING IS TO THE REQUIRED SPECIFICATIONS. JOEL'S GARAGE GEAR WILL NOT BE RESPONSIBLE FOR ANY CHARGES RELATING TO NEW CONCRETE SLABS POURING, LEVELING OR DAMAGE.**



## HOIST LOCATION LAYOUT

Before any installation can occur, we recommend first completing a layout out of the hoist location. The minimum bay size required (that is free unobstructed space) to install is 7200mm [L] x 3600mm [W] x 3650mm [H]

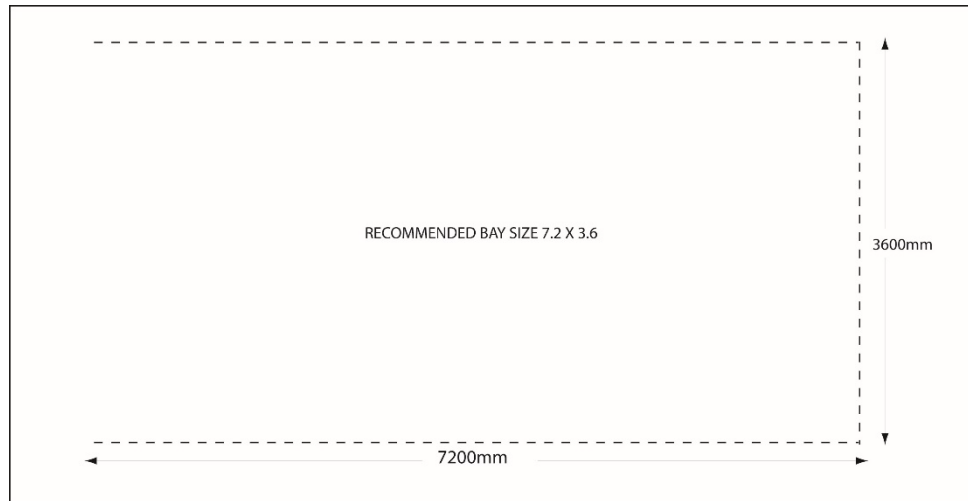

## LAYOUT THE INSTALLATION AREA.

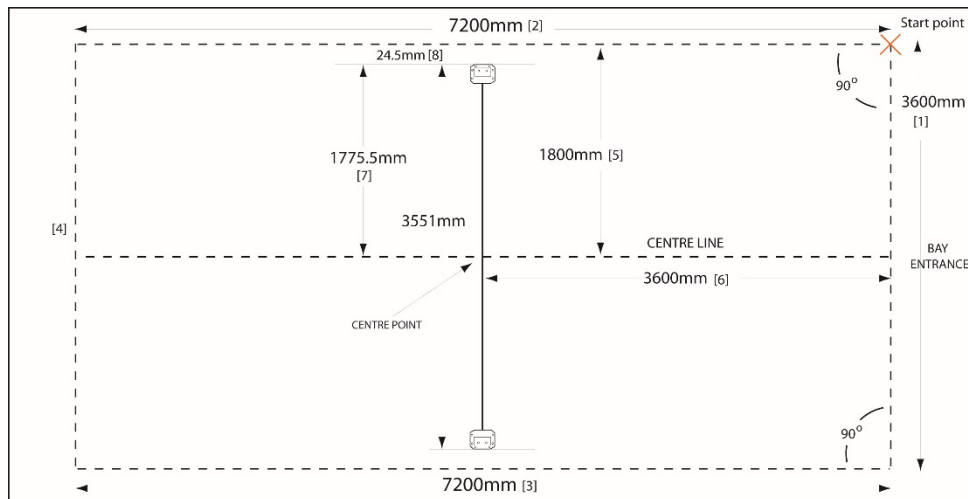

Using a measuring tape, start at one corner of the proposed area and mark a line 3600mm [1] long. Typically this is across the entrance to the bay. Working from the same start point, draw a line 90 degrees to the first line 7200mm [2] long down one side. Mark another 7200mm line [3] also at 90 degrees to the first line. At the end, draw another 3600mm [4] line that joins the two 7200 lines to complete a rectangle on the floor.

Typically, the hoist will sit in the centre of the 7200mm length. To make the centre point, measure 1800mm [5] down the entrance line and the back line [4] and join the two together, creating a line down the centre of the rectangle. Next measure and mark each side of the 7200 lines at 3600 [6] and draw a line down, crossing over the centre line which will create the centre point.

From the centre point, measure out 1775.5 mm [7] each side from the centre and mark the floor. (There should then be a 24.5mm gap between the end of the centre line and the edge [8]). This is the position where the hoist column uprights will be located.

## IMPORTANT AND GENERAL INFORMATION FOR EXPANSION ANCHORS

### Instructions for Installing Concrete Anchors

These general instructions for the installer are provided to ensure the proper installation of Expansion Anchor Products.

- The Concrete substrate shall have compression strength of at least **32MPa** using RL1118 mesh and a minimum thickness of 125mm.
- A minimum distance of 200mm must be maintained from any slab edge or seam. Hole to hole spacing should be a minimum 165mm in any direction. The hole depth should be a minimum of 110mm.
- Each anchor must be seated to a minimum depth of 85mm. **NOTE:** If the top of the anchor exceeds 55mm above the floor the anchor depth is not deep enough, which will cause the anchor to fail.
- Do not modify or change Mechanical Wedge Anchor products. The manufacturer will not warrant or guarantee the performance of any modified products which will void your warranty.
- Do not alter installation procedures from those set forth in this Manual.
- Drill holes for mechanical anchors with carbide-tipped drill bits that meet the diameter requirements of ANSI B212.15. A properly sized hole is critical to the performance of mechanical anchors.
- Rotary-hammer drills with light, high frequency impact is recommended for drilling holes.
- Do not use excessively worn bits or bits which have been incorrectly sharpened.
- Please note that the use of oversized holes is **NOT** permitted for anchoring any lift. **DO NOT USE** Anchor Adhesive to fill spacing of oversize holes. Move lift location and Re-drill to correct hole Specification.
- Do not disturb, bolt up, or apply load to adhesive anchors prior to the full cure of any adhesive.
- Metal anchors and fasteners will corrode and may lose load-carrying capacity when installed in corrosive environments or exposed to corrosive materials. There are many environments and materials which may cause corrosion including ocean salt air, fire-retardants, fumes, fertilizers, preservative-treated wood, dissimilar metals, and other corrosive elements.

## EXPANSION ANCHOR INSTALLATION INSTRUCTIONS 20mm X 140mm

Anchor size is same as drill bit size 20mm.

Use a hammer drill with a 20mm diameter Carbide tip drill bit. The bit tip diameter should be ANSI Standard B95.12-1977.

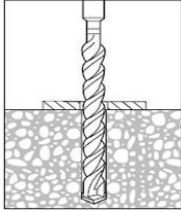
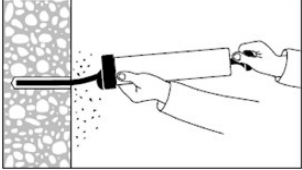
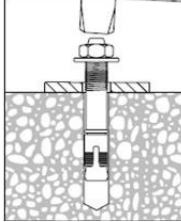
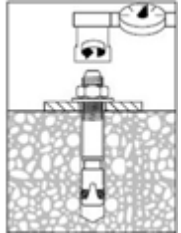
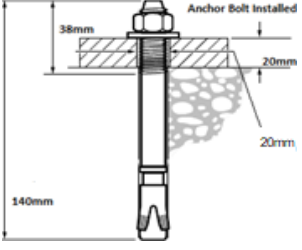
	<p>Hammer drill a hole to the same diameter as the expansion anchor (in this case 20mm). Use the baseplate as a drilling template to ensure proper anchor locations.</p>
	<p>Clean hole completely. Remove dirt and dust with the use of a shop vac or an air compressor</p>
	<p>Assemble the flat washer and nut flush on the anchor bolt, leaving about 2mm exposed above the nut. Drive the expansion anchor into the hole using a hammer and wood. If shimming is required, make sure to leave threads exposed for proper shimming</p>
	<p>Tighten the nut to the recommended installation torque</p>
	<p>Installation Complete</p>

# CAR LIFT DIMENSIONS

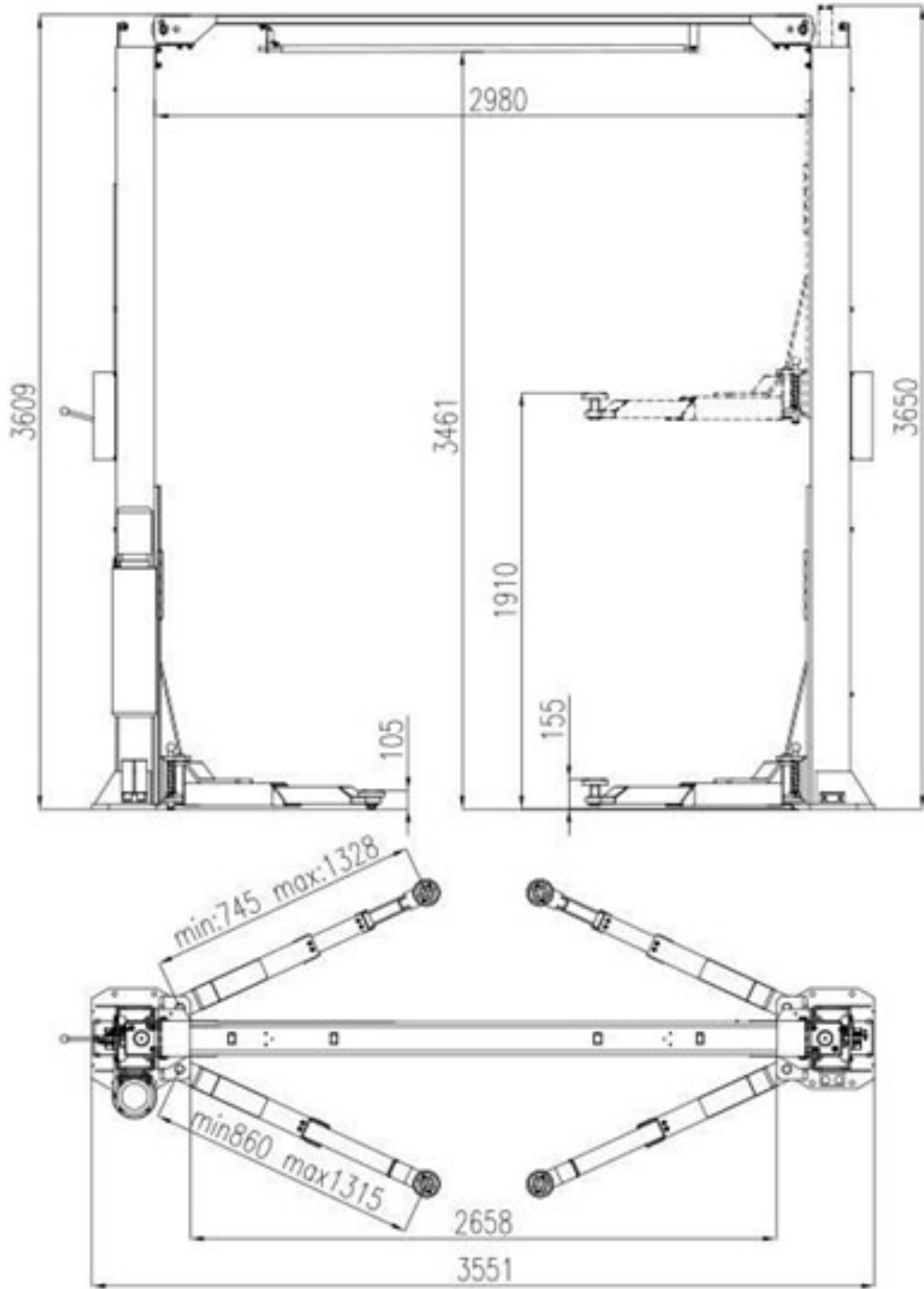

# GENERAL ASSEMBLY COMPONENTS

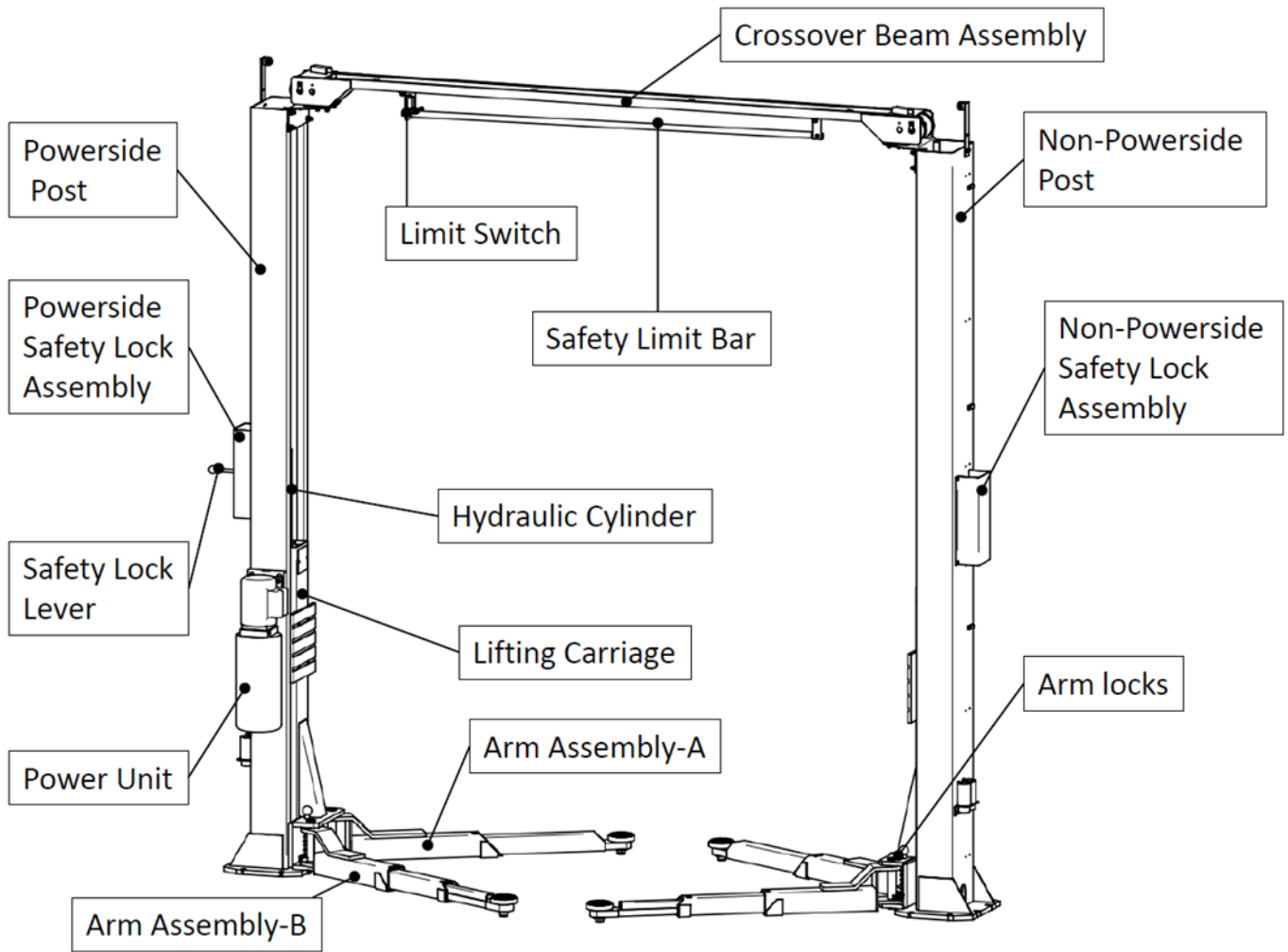

## INSTALLATION PROCEDURE

If you are installing this hoist as a DIY install, it is strongly recommended that you have at least one other person as extra help or have heavy duty lifting equipment when unloading and assembling the hoist. Never attempt to lift components without proper lifting tools such as sling bands, forklift or crane. Be aware and stay clear of any moving parts that can fall and cause injury.

### UNPACKING THE HOIST

- When unloading the hoist, place it as near as possible to the intended installation location.
- The power unit is located on the top and should be unpacked first. **Note:** The power unit is heavy, be careful not to drop the power unit. Place the power unit aside out of the way.
- Start by first removing the shipping bands and packing materials from the hoist. Open the wrapping, remove the parts and parts boxes from the packaging.
- Using the parts list contained check that all parts are accounted for. If **any parts are missing**, please advise Joel's Garage Gear immediately.
- Unbolt the structure from the shipping brackets. (Where available use proper lifting devices, cranes or a forklift to lift off shipping brackets.)

### COLUMN CABLE INSTALLATION

Before raising the columns route the cables in each column as illustrated [4]. The stop connector will seat on the rear upper stop plate.

Remove the access panel on the front of the carriage. Feed the equalizer cable down through the rear top mounting of carriage and around lower sheave. Be sure to pull the cable all the way through until sitting flush on top mounting point

Make sure the cable is routed down toward the pulley on the base plate then routed back up towards the front of the carriage. Remove all the cable slack by lowering the lifting carriage and pulling the cable tight. Wind the remaining cable into the column. This will make installing the cables easier before raising columns.

[4]

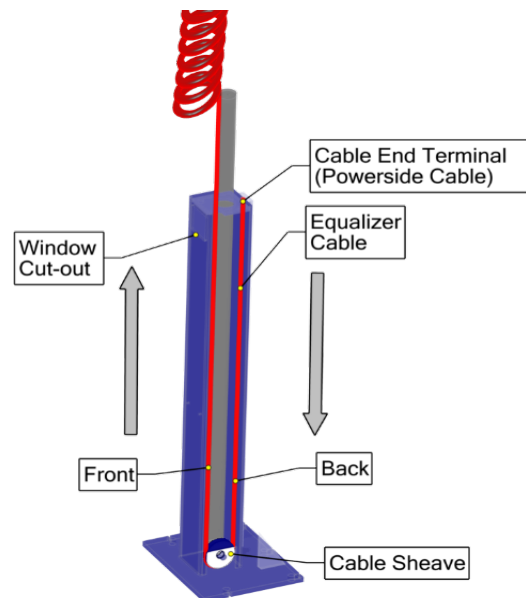

Next, remove the bottom sheave, wrap cable around sheave and replace sheave after lubricating with HTB Grease and cable. Re-install after cable has been routed. [5]

Push the equalizer cables up through the bottom of the carriage. The cable must run through that front hole on the same side and out the top of the carriage. Wrap the remaining portion of cable inside column.

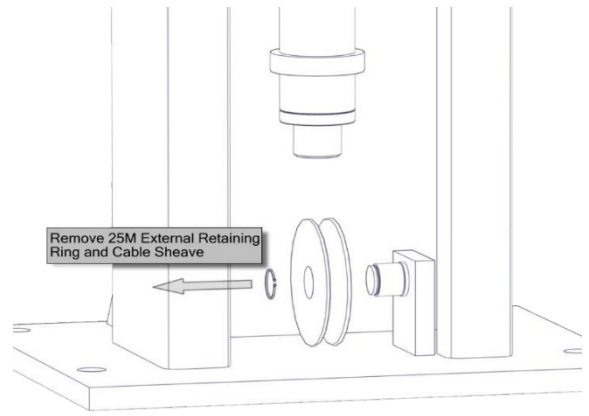

[5]

### INSTALL THE SAFETY CABLE BRACKET ON BOTH COLUMNS.

Next fit out the **Safety Cable Bracket Assembly**. [6]

First, insert the Safety Pulley into the U channel on the **Safety Cable Bracket Assembly**, then insert the M8 x 30mm bolt. Fasten the bolt using a Nylon M8 hex nut.

Be sure to use the correct fittings and fixtures as listed. There are two **Safety Cable Brackets** to be assembled.

[6]

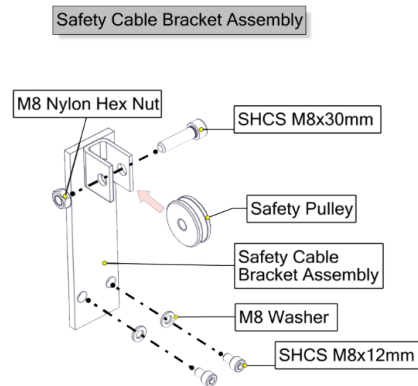

Install **Safety Cable Bracket Assembly** [7]

With the **Safety Cable Bracket** both assembled, install each bracket into the column by using 2 x M8 x 12mm bolts and M8 washers. [7]

The column has a threaded insert to which the M8 bolt will screw into and fasten.

[7]

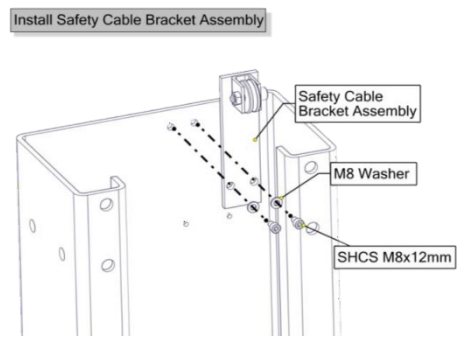

## INSTALL THE CROSSOVER BEAM PLATE CONNECTION.

The **Crossover Beam Plate** is located at the top of each column.[8]

Affix the **Plate Connection Crossbeam** to the column using 4 x M12 x 35mm bolts, M12 washer, M12 locking washer, and finally M12 Nylon lock nut.

[8]

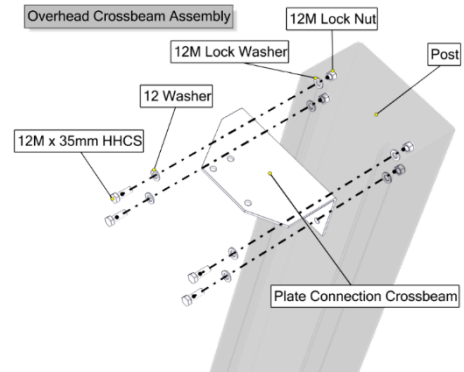

The completed **Plate Connection Crossbeam**. [9]

[9]

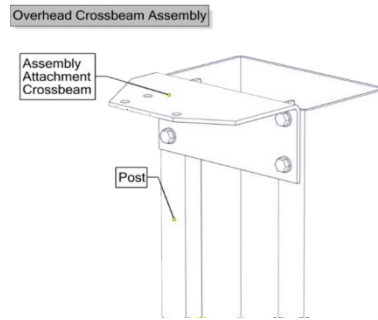



## INSTALLING THE COLUMNS

Using the line template created earlier, raise the columns and position each column facing each other. Pay particular attention to the column position. Double check each column is placed in the right position.

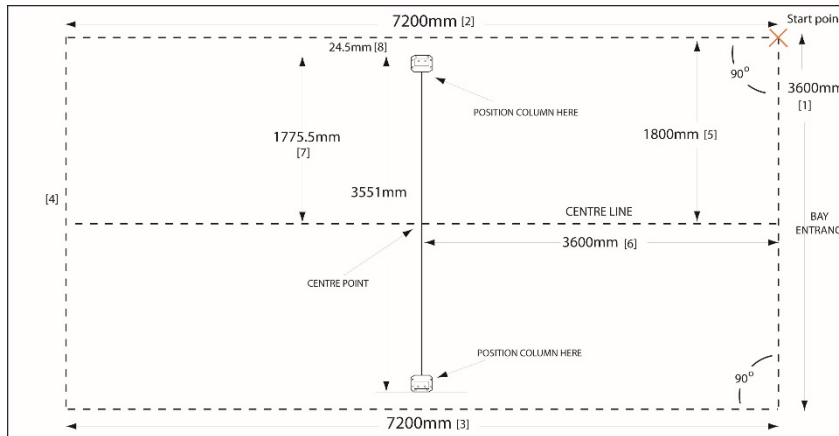

To secure the columns, work from the left-hand side first. Position the left-hand side column in the previously marked location and mark the holes using the column base plate as a guide.

Using a hammer drill, carefully drill out the centre hole **only** using the base plate as a guide [10]. To install the expansion anchor, place a flat washer and hex nut over threaded end of the 20mm x 140mm anchor, and screw down the nut leaving approximately 2mm of thread exposed above the nut. Carefully tap the anchor (use a hammer and a block of wood) until it is well seated in the hole with the nut and flat washer against base plate. Do not damage threads. Do not overly tighten the nut at this stage.

Place the other column in the position marked out but do not drill any anchor points till after the crossbeam has been installed.

### CRITICALLY IMPORTANT –

**\*\*\*ONLY ANCHOR ONE COLUMN WITH (1) ANCHOR FOR ALIGNMENT AT THIS TIME ONLY\*\*\***

The remaining anchors will be installed after the overhead crossbeam has been installed. Column displayed is for illustration purposes.

[10]

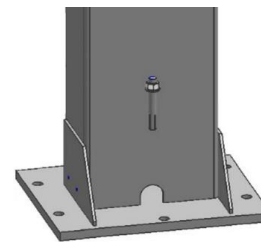

## DRILLING FOR EXPANSION ANCHORS.

**CAUTION:** Anchors must be at least 200mm from the edge of the slab or any seam.

- Use only the recommended bit size (20mm) and type - masonry.
- Keep the drill in a perpendicular line while drilling.
- Let the drill do the work. Do not apply excessive pressure. Lift the drill up and down occasionally to remove residue to reduce binding.
- Drill the hole to a depth equal to the length of anchor. **Note:** Drilling all the way through the concrete will allow the anchor to be driven through the bottom of foundation. By drilling right through, if the threads are damaged or if the lift needs to be relocated it is easier to remove the expansion anchor.
- After drilling blow the dust from the hole.

## ASSEMBLE THE OVERHEAD CROSSOVER BEAM

Begin by first attaching the **Limit Switch** to the Switch bracket using 2 x M4 x 12mm and 2 x M4 x 25mm screws.

Next connect the Switch bracket to the overhead cross beam (in the holes provided) using 2 x M12 x 25mm bolts with 4 x M12 washers, top and bottom and two M12 nylon lock nuts

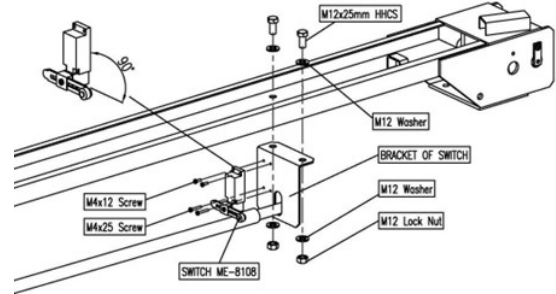

At the other end of the overhead crossbeam connect the Safety Tube Bar Bracket using 1 x M12 x 25mm bolt, with 2 x M12 washer and single M12 lock nut.

Install the crossbar tube by first inserting it into the Switch Bracket at the other end, then using a M8 x 45mm bolt a M12 washer followed by an M12 spring washer and M12 nut to fasten the crossbar tube.

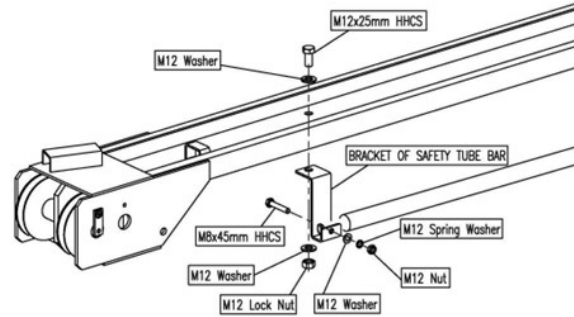

## INSTALL THE OVERHEAD CROSSOVER BEAM.

To install the crossover beam, using a tape measure, measure from the back corner of the column base to the opposite back corner to ensure columns are inline and square. (Refer to the layout guide) After confirming dimensions, install the Overhead Crossbeam by raising it on to the column and lining it up to the Assembly Attachment Crossbeam mounting points.

Make sure to use proper lifting devices (cranes, forklift, etc..), or **USE HELPERS with ladders** to install crossover beam.

Use extreme caution when installing the crossover beam. **CROSSBEAM IS TOP HEAVY.** Use 3 x M10 x 30mm bolts with 2 x M10 washers per bolt, and a M10 nylon locking nut. Tighten the hardware once the installation of the overhead crossbeam is complete.

All hardware must be installed from inside of the crossbeam facing out. This is to avoid interference with the cables and pulleys when operating the hoist.

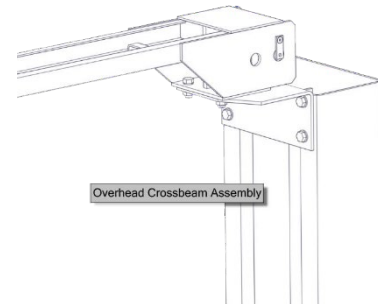
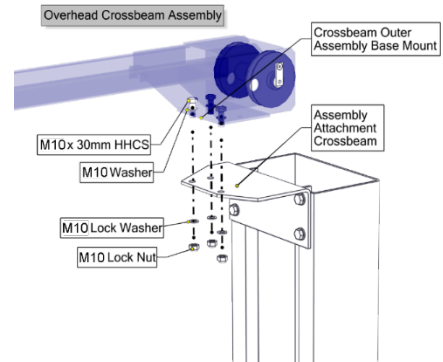

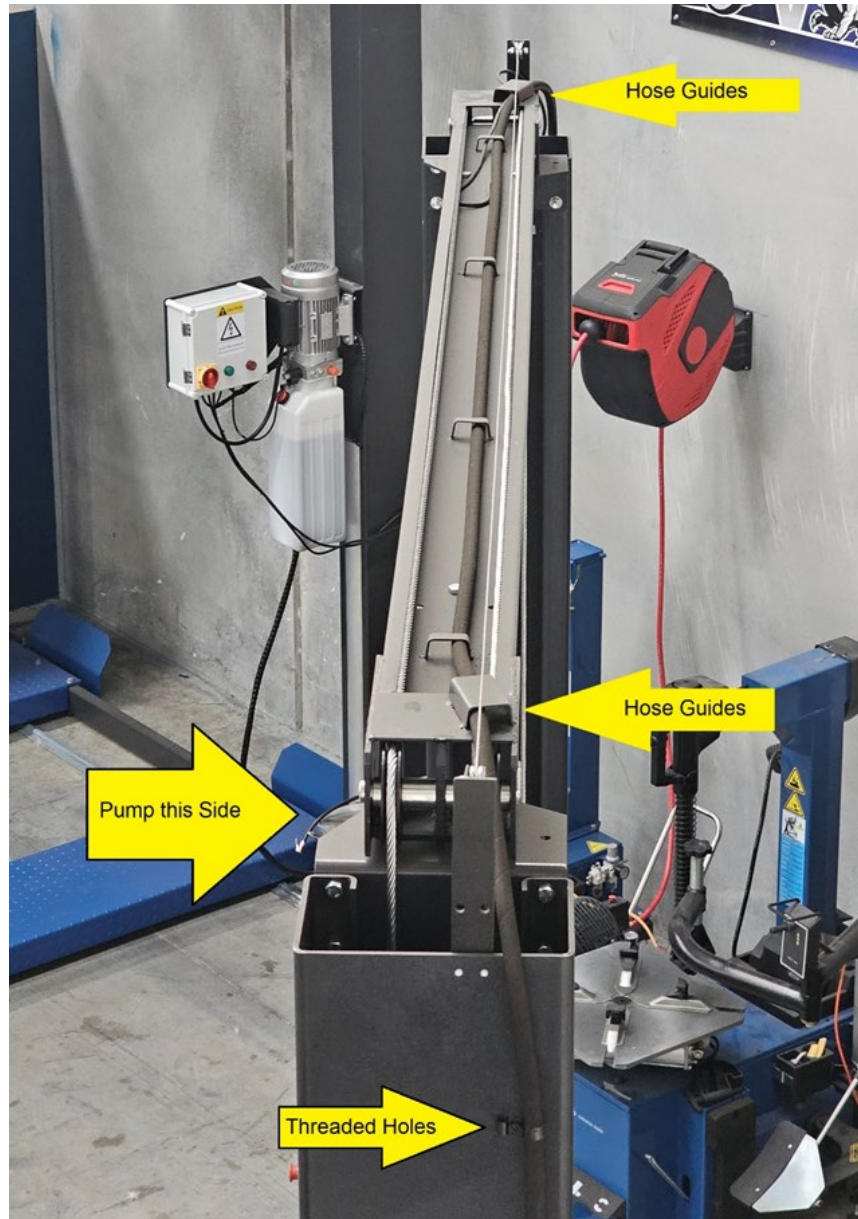

## INSTALLING EXPANSION ANCHORS AND LEVELING THE COLUMNS

With the crossbeam now installed,

- Using a spirit level, check the columns are both straight (plumb) and level. If the column is not plumb, using the horseshoe shims provided, shim the column base as required until each column is plumb. If one column must be elevated to match the plane of the other column, add shim plates. Shim thickness **MUST NOT** exceed 12.5mm when using the 140mm long anchors provided with the lift.
- Once the columns are both straight and in position, complete the installation of the remaining anchor bolts by drilling the remaining holes on both posts. Use the base plate as a template for drilling the holes. We recommend drilling a single hole first in the opposite column that contains no anchor and insert a single anchor. This will stabilize the column making it safer to drill the additional holes on both sides.

- When installing the expansion anchors, like previously instructed, place a flat washer and hex nut over the threaded end of 20mm x 140mm anchor, leaving approximately 2mm of thread exposed carefully tap anchor (use a hammer and a block of wood). Do not damage threads. Tap anchor into the concrete until nut and flat washer are against base plate.
- Tighten the nuts on each bolt two or three turns. Check each anchor bolt with a torque wrench set to 100-foot pounds' torque. Re tighten the expansion anchors several hours after the initial installation. The anchors should be checked weekly to make sure they are properly affixed.
- **ATTENTION:** Mechanical anchors require a specific installation torque: Failure to apply the recommended installation torque can result in excessive displacement of the anchor under load or premature failure of the anchor. These anchors will lose pre-tension after setting due to pre-load relaxation.
- If anchors **do not tighten to 150 Nm**. installation torque, replace the concrete under each column base with a **1.2m x 1.2m x 125mm thick 32MPa minimum concrete pad** keyed under and flush with the top of existing floor. Allow concrete to cure before installing lifts and anchors (typically 28 days).

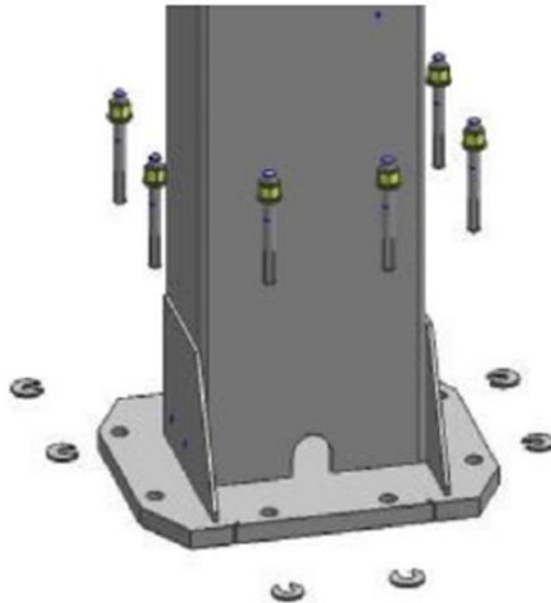

## RUNNING THE EQUALIZER CABLES

Connect the equalizing cables as shown in the diagram.

Note the direction that each cable runs and where each cable terminates.

Do not tighten completely at this stage of assembly. Hand tight only.

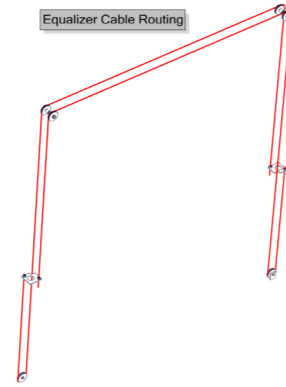

Start by removing the panel on the front of the carriage.

Fasten the cable end with the hex nut on end until 12mm of threads show above hex nut and insert it into the **Cable End Terminal** (Powerside cable). Pull down through Cable Sheave until properly seated.

To route the cables through the crossover beam sheaves, remove the sheaves in the crossbeam by removing the M6 screw that holds the Pin in place. Remove the pin and run the cable through then reinsert the sheaves. At the other side (Non-Powerside) fasten the cable facing down on the opposite side column front mounting point.

When replacing the sheaves, apply some grease to the bushings for smoother operation.

Check that the cables are correctly wrapped over all sheaves before completely adjusting cables or operating the hoist.

**Note: make sure not to cross cables over each other when cable is routed back down opposite side column**

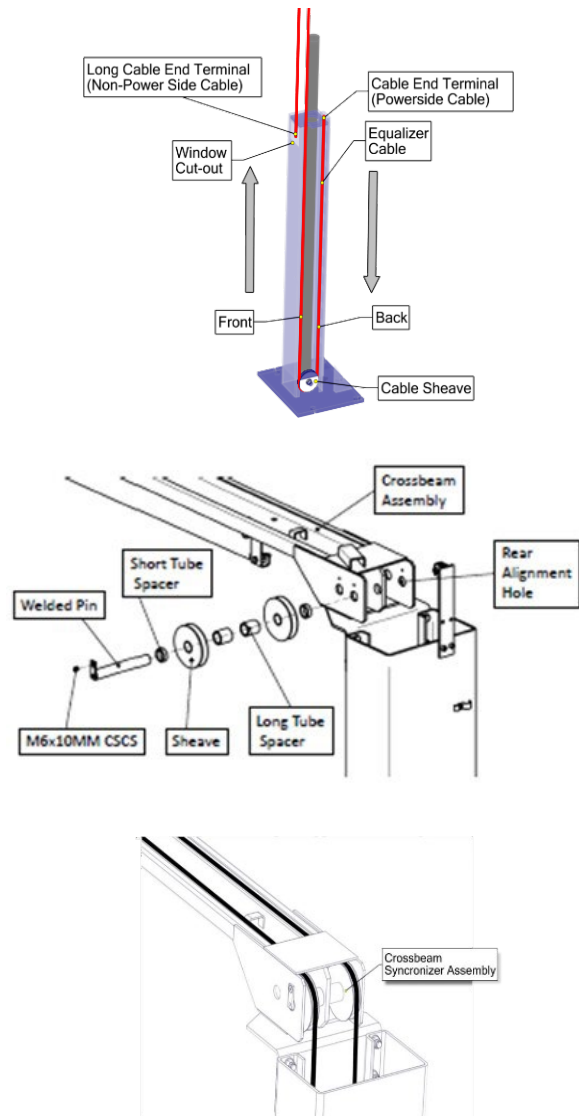

**Adjusting the carriage cable tension.**

This is performed by tightening the (2) M18 tie off hex nuts where each cable connects to the carriage. Adjust each cable to approximately 12mm side-to-side play.

**Note: The left post carriage nut adjusts the right column carriage, and the right column carriage nut adjusts the left column carriage**

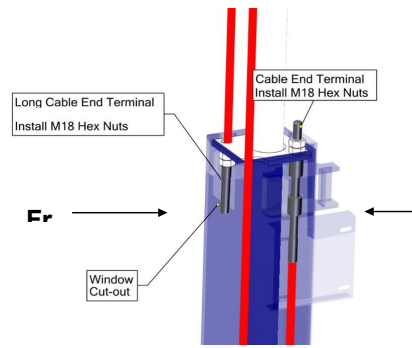

**SAFETY LATCHES AND SAFETY CABLE**

**INSTALL NON-POWERSIDE SAFETY LATCH SYSTEM.**

**Install the M38 Safety Pulley**

Locate the Safety Pulley M38. Insert the Safety Pulley into the Safety Pulley Bracket Non-Powerside and affix using a M8 x 30mm bolt and M8 nylon hex nut.

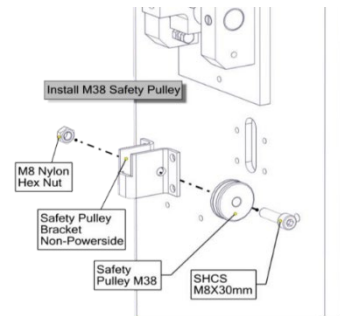

**Install Non-powerside Safety Pulley Bracket to the column.**

Attach the **Safety Pulley Bracket Non-Powerside** to the column using 4 x M6 x 10mm bolts with 4 x M6 washers.

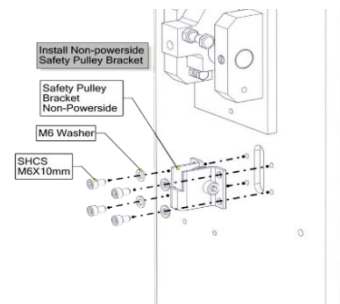

**Install the M35 Pulley into Safety Bracket Pulley**

Locate the Safety Pulley M35. Insert the **M35 Safety Pulley** into the Safety Bracket Pulley A and affix using a M8 x 30mm bolt and M8 nylon hex nut.

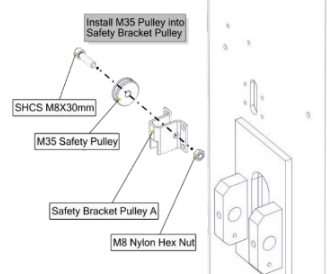

**Install Powerside Safety Pulley Bracket to the column.**

Attach the **Safety Pulley Bracket A** to the column using 4 x M6 x 10mm bolts with 4 x M6 washers.

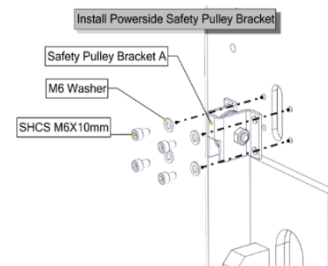

## INSTALL POWERSIDE SAFETY LATCH SYSTEM.

To install the **Powerside and non powerside Safety Latch System**

Locate the **Safety Limit Stop** component. On the Powerside, Safety Ladder Lock first attach the Safety Limit Stop using 2 x M6 x 10mm bolts. On the Safety Ladder Lock affix a M6 x 20mm with hex nut into the housing.

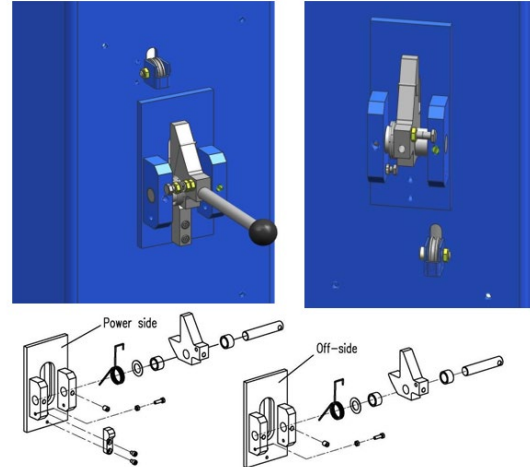

## INSTALL AND ROUTE THE SAFETY CABLE

The Safety Cable is routed from the Non-powerside to the Powerside and is contained on the inside of each column.

Pay close attention to the connection points and the nut and bolt configuration.

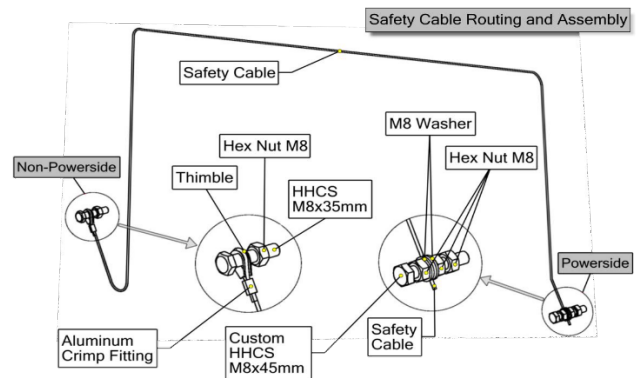

### Install the Safety Cable

Route the safety cable through the columns over the Safety Bracket Assembly and affix it to the custom M8x45mm HHCS on each side. Attach the safety latch assembly on each side by tightening the M8 Hex Nuts and the M8 Flat washers together.

**Note:** Before tightening check that cable is routed over all safety cable bracket assemble sheaves.

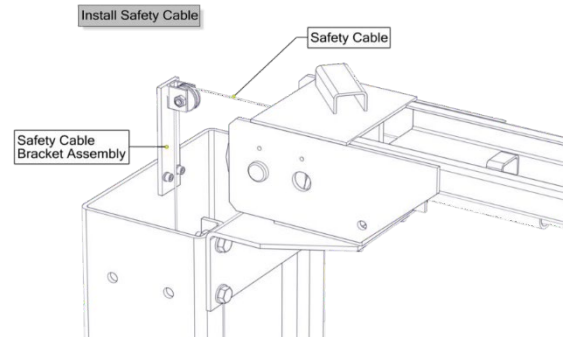

**Verify connection of the safety cable between the two latches.**

Check that the tension of the cable is tight. Pull the safety release handle several times and check the tension again by making sure both latches are adjusted correctly by pulling down on the power side Safety Lock Lever.

The safety release locks must click at the same time when the handle is pulled and released. Retighten as needed until adjusted properly. **Important: Always verify that Both Safety Latches are released before lowering vehicle.**

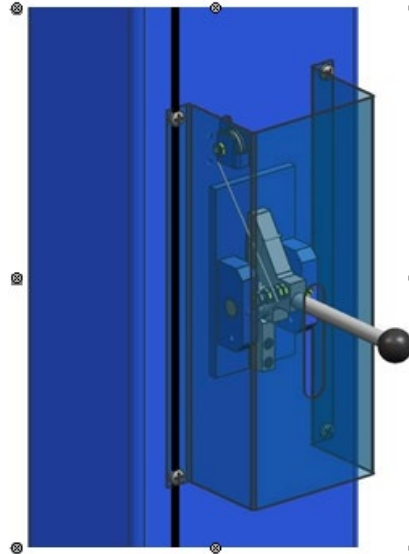

The Safety cable will stretch within the first few uses and will require to be adjusted periodically.

To tighten the Safety Cable, tighten the M8 nut next to the washer.

**Note:** Do not over tighten as this will result in a malfunction of locking mechanisms and may snap the cable

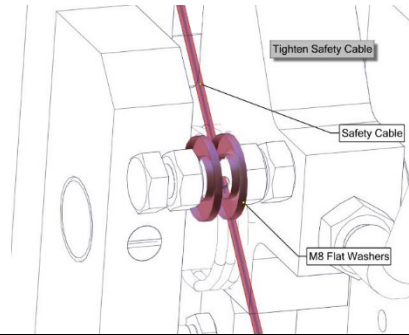



## INSTALL NON-POWERSIDE SAFETY COVER.

Install the **Non-Powerside Safety Cover**

Align the Non-Powerside Safety Cover to the predrilled holes on the column and affix it using 4 x M8 x 12mm bolts.

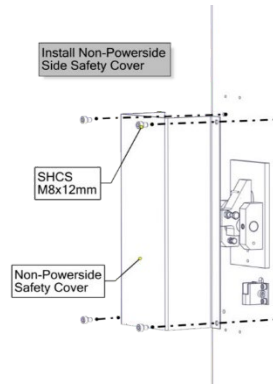

## INSTALL THE POWER SIDE SAFETY COVER.

Install the **Powerside Safety Cover**

Align the **Powerside Safety Cover** to the predrilled holes on the column and affix it using 4 x M8 x 12mm bolts.

Route Electrical Cable down outside of Powerside post which will be connected to power unit .

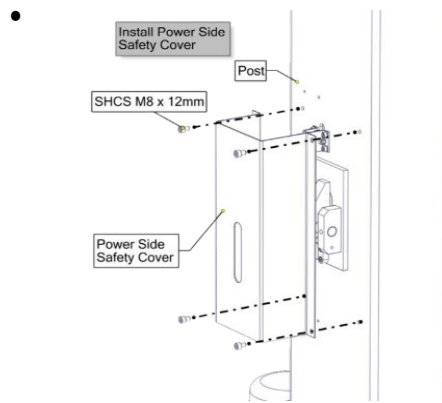

Install the **arm extension brackets**.

There is (1) bracket to be installed on both the Powerside and Non-Powerside columns.

Place the Arm Extension Adaptor Brackets into the column and affix it to the columns using 4 x M8 bolts with M8 washers and M8 Lock washers.

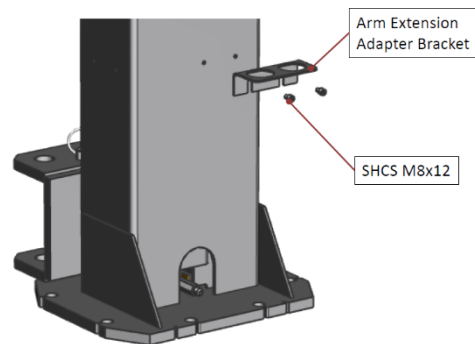

## INSTALL THE POWER UNIT

Install the power unit on the Powerside column bracket mount using the four (4) x M10 x 20mm with M8 washers and M8 nylon lock nuts.

Tighten the locking nuts so that the power unit does not move in any direction.

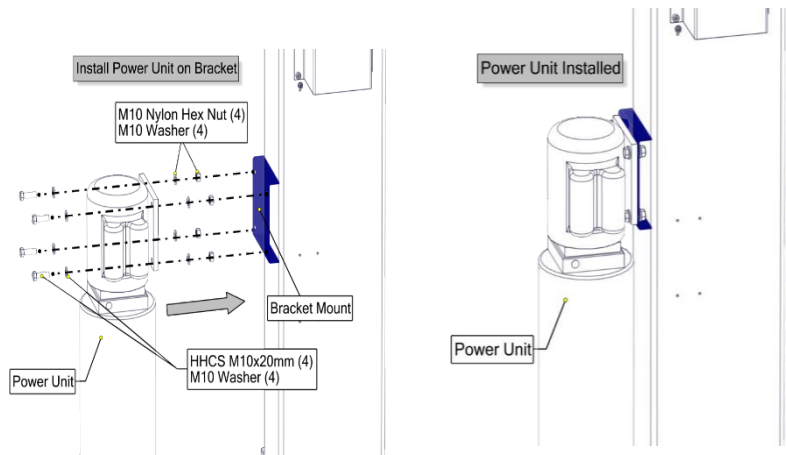

## INSTALL THE HYDRAULIC SYSTEM HOSES

The hoist hydraulic system runs a hydraulic line between each hydraulic cylinder, which connects to the Power Unit as shown in the routing image to the right.

There are three (3) hydraulic lines of different lengths.

They include.

- 1 x 9220mm (Long)
- 1 x 1040mm (Medium)
- 1 x 360mm (Small)

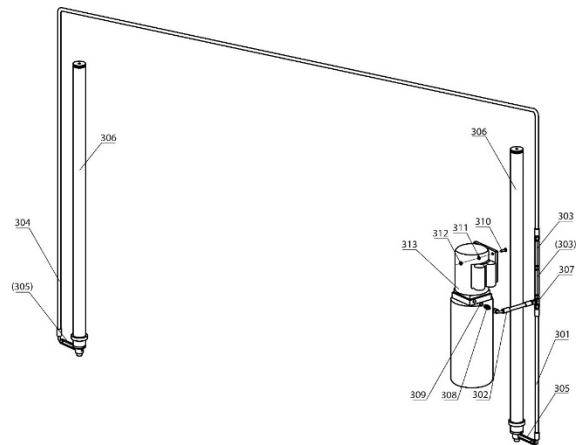

To connect the hydraulic system, first route the 9220mm (long hose) along the back of the columns and over the crossover beam assembly as shown in the diagram. This is the same for both the left and right sides.

Pay close attention to route the hydraulic hose through the brackets on the crossover beam as shown to avoid any potential binding with the safety and equalizer cables

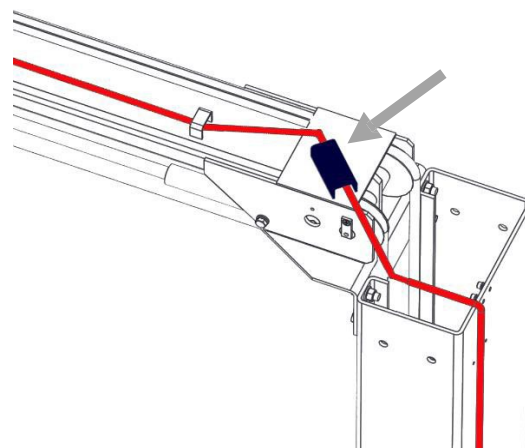

On the non-Powerside connect the long hose end to the **Cylinder Fitting** located at the base of the column.

On the Powerside connect the other end of the long hose to one side of the **'T' fitting**.

Using the 1040mm (medium hose) connect one end to the Cylinder Fitting and the other end to the 'T' Fitting.

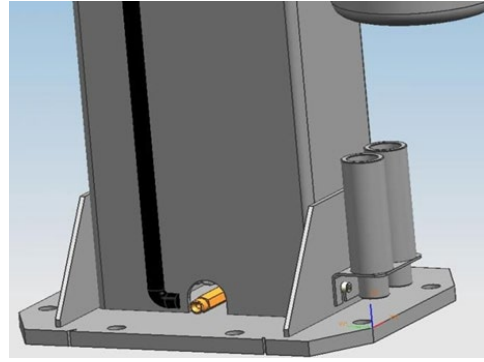

On the power unit side connect the 360mm (short hose) to the power unit fitting then connect the other end of the 360mm hose to the "T-fitting".

If the fitting is located on the incorrect side of the power unit, it can simply be swapped to the opposite side. It may be tight and require some impact from an aluminium dolly to free up.

Secure the hoses along the columns and make sure all the connection fittings are tight.

**NOTE:** do not use Teflon tape with JIS fittings, it will damage the fittings as well as cause failures and oil leakage.

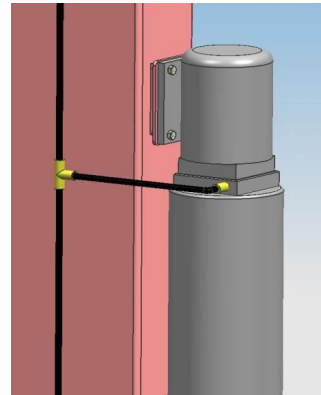

### Filling the Power Unit with hydraulic oil.

Remove the oil cap on the power unit and using a funnel fill the reservoir with hydraulic oil.

It is recommended to use a non-foaming, non-detergent hydraulic fluid Ten Weight (Hydraulic Oil ISO AW32 or 46).

The unit will hold approximately 12L

**NOTE** Hydraulic oil must be changed after the first week of operation and then every 12 months or as needed depending on frequency of use.

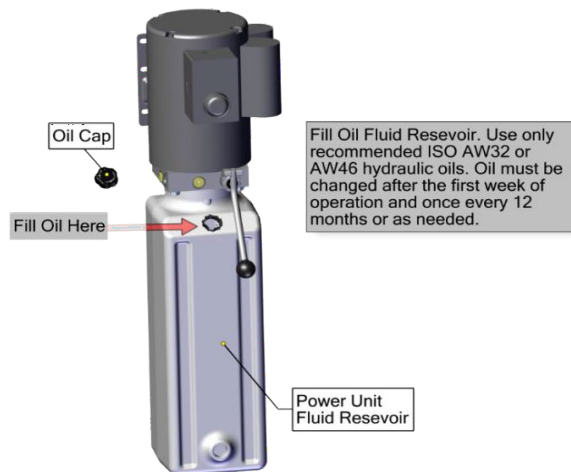

## CONNECT ELECTRICAL TO THE POWER UNIT; .

 **WARNING:** A certified electrician must install all electrical wiring. Each circuit should have protection with a time delay fuse or circuit breaker. A commercial licensed electrician is recommended to understand the circuitry of the hoist and complete the electrical works.

Minimum requirements required include,

- A 20Amp dedicated circuit with a D curve Breaker.
- An isolator switch mounted close to the hoist location.

 **WARNING:**

**Lock Out (disconnect) electrical supply before installing any electrical components or performing maintenance on the lift. Do not ever allow power supply to be connected when working on or repairing lift.**

## INSTALLING LIFT ARMS

Prior to installing the lifting carriage arms, first test fit the arm pins into the Lifting Carriage Alignment Hole.

The arm pins should rest in the holes easily. If the arm pins are too tight remove a little residual powder coating inside the Lifting Carriage by using a round file to clean the holes. The drop pins should then slide easily and fit snug.

**Note:** Do not use a Dremel to clean the hole/s, this could cause an over-sizing of the hole/s which will result in the arm pins not fitting securely and safely.

Now raise both lifting carriages at the same time once power has been turned onto the power unit to assist in installing the arms. Make sure hydraulic rams are aligned in carriage.

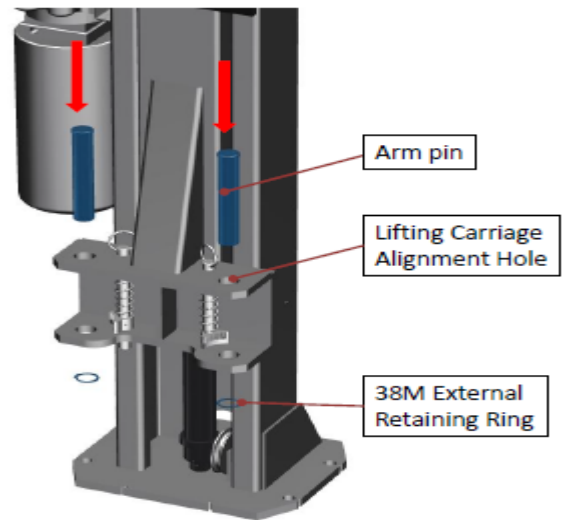

Install the arms by extending them to near full extended length. (3 Stage arms will generally go toward the front of the vehicle, 2 stage to the rear)

Next place the arm over the holes on the lifting carriage. When centered and aligned with the hole, insert the arm pin. If the fit is tight gently tap the pin using a block of wood and a hammer.

Repeat the same process for each arm until all 4 arms are installed.

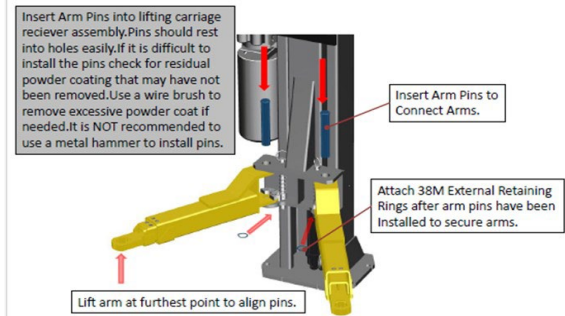

To complete the arm install, raise both lifting carriages to the first lock position.

While in this position attach the 38mm External Retaining Ring on all lift arm drop pins

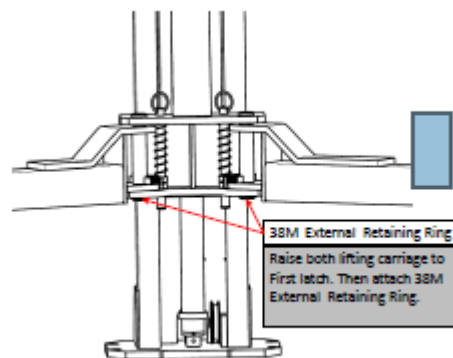

Check the “half-moon” gear restraints on each lifting arm are already installed. Position the lifting arms on the carriages. Check for proper engagement of the arm restraints (arm locks).

The safety gear restraints should fully engage the gear restraints on the arm. After checking that the safety gear restraints and arm gear engage properly. Verify that Allen Bolts on gear restraints are tight and secure

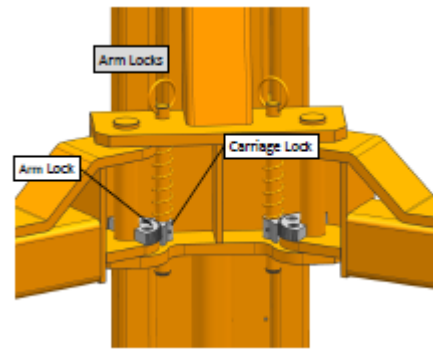

Next attach the Lift Pad to the Lift Arms by inserting the lift pad into the arm receiver hole.

If the arm receiver hole is tight use some sandpaper or light duty file and remove the obstruction by gently rubbing the inside ring.

**NOTE:** Always check pads for secure contact with vehicle before operating

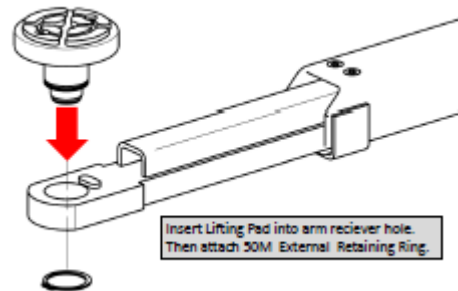

## AIR PURGE PROCEDURE

Fold the arms inwards to avoid hitting the power unit.

Without any weight on the hoist, raise the cylinders 500mm off the ground just high enough to clear locking mechanisms. Slowly loosen the bleed screws located at the top of each cylinder. (One or two turns should be all that is needed to remove the air). **DO NOT REMOVE BLEED SCREW COMPLETELY.** Listen for air to release and watch for clean fluid to escape from each cylinder then tighten. Continue to raise the cylinders to full height and lower the lifting carriage to an unlocked position 500mm off the ground. Slowly loosen the bleed screws located at the top of each cylinder. (One or two turns should be all that is needed to remove the air). **DO NOT REMOVE BLEED SCREW COMPLETELY.** Listen for air to release and watch for clean fluid to escape from each cylinder. Repeat steps if air is still in the cylinder.

**NOTE:** If cylinder continues to shake or vibrate when lifted or lowered repeat steps until trapped air is removed from cylinders. (Use a ladder for safety.)

### Bleed Screw Instructions

Without any weight on the lift raise cylinders on full rotation and lower the lifting arms to an unlocked position 2 feet off the ground. Slowly loosen the bleed screws located at the top of each cylinder. (One or two turns should be all that is needed to remove the air). **DO NOT REMOVE BLEED SCREW COMPLETELY.** Listen for air to release and watch for clean fluid to escape from each cylinder. Repeat steps if air is still in the cylinder. **NOTE:** If cylinder continues to shake or vibrate when lifted or lowered repeat steps until trapped air is removed from cylinders. (Use a ladder for safety)

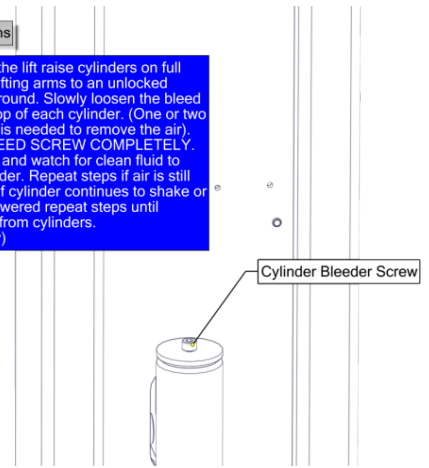

## SYNCHRONIZING EQUALIZING CABLES AND LOCKS

With no weight (load) on the hoist, cycle it up and down several times to ensure the safety latches engage properly and all air is removed from the hydraulic system.

To lower the hoist, first raise the hoist to clear the safety latches, then pull down the safety release handle to disengage the locks.

Re - raise the hoist and LISTEN. You will hear the lock latches begin to hit and release as the hoist is being raised.

After 3 or 4 clicks you will hear the latches synchronizing at the same time. If the safety latches are out of synchronization, you will have to re-adjust the equalizing cables on the hoist

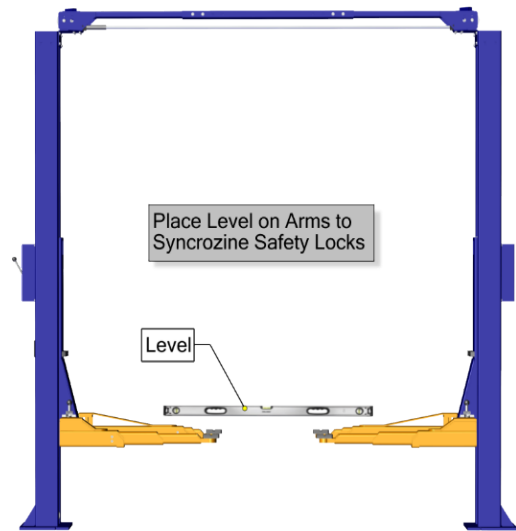

### Synchronizing cables

If safety latches are out of sync, adjust the cable on the latch that engages first.

To adjust, tighten the Long Cable End Terminal on the latch that is engaging first. This could be either the Powerside or Non-Powerside Posts.

The safety lock latches and cables should now be synchronized.

### CAUTION

#### Equalizing Cables Important Notice:

Equalizing Cables must be checked with each daily inspection. The tension should not exceed 25mm of tension slack. Failure to keep cables synchronized could cause an uneven lift which could result in the vehicle falling off the hoist.

Equalizing cables should always be maintained so the safety latches are in sync with the safety locks. Always check that both safety latches are engaging on the appropriate latch.

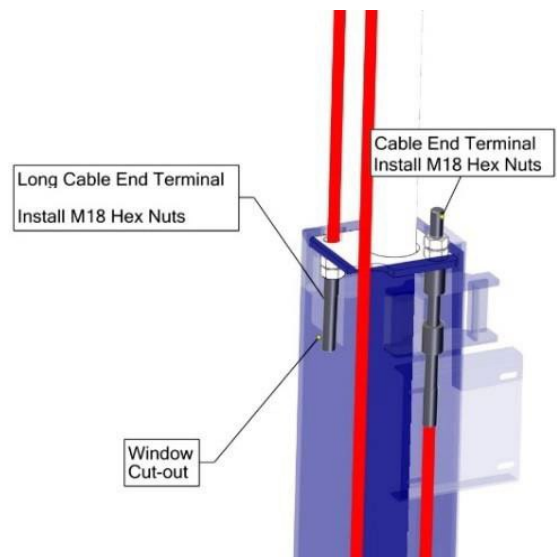



**POST INSTALLATION PROCEDURE:**

✓ Check boxes to verify work has been completed.

	Verify columns are properly shimmed and plumb
	Check that expansion anchors are tightened to 150. NM torque
	Roll pins / sheave pins / hardware / fasteners properly attached and torqued
	Lifting carriage gear restraints securely fastened
	Electrically wired by a professional technician
	Equalizing cables and safety latches in synchronization
	Safety latches functioning properly
	Check for “no” hydraulic leaks
	Oil level full
	All components functioning properly
	All integral moving parts lubricated
	Check for overhead obstructions
	Lifting arms level and on the correct side in relation to the power unit.
	All hardware secure (nuts, bolts, pins)
	Test limit switch operation
	Working area clean
	Operation, maintenance and safety manuals in designated location
	Lubricate the four inside corners of the columns with heavy duty bearing grease



# **OPERATION MANUAL**

**JGG-45CF**

**2 POST CLEAR FLOOR HOIST**

## OPERATOR TRAINING AND SAFE PRACTICES.

Keep a copy of these instructions close by and stored in a protected dry location readily available for operators. Each operator must read and carefully follow all safety instructions. Ensure all operators understand how to operate the product safely and correctly before use. Failure to operate this product as intended may cause injury or death.

Prior to each use, on a regular basis carefully inspect the product and perform all maintenance as required. Service and maintain the product only with authorized or approved replacement parts; negligence will make the product unsafe for use and may void the warranty.

Keep and maintain that all decals on the product remain clean and visible. Do not modify and/or use this product for any application other than that for which this product was designed. If you have any questions related to a particular application contrary to the product's specific functions, **DO NOT** use the product until you have first contacted **Joel's Garage Gear** to determine if it can be performed using the product.

## GENERAL SAFETY RULES



**WARNING: Read and understand all instructions.** Failure to follow all instructions listed below may result in serious injury or death.



**WARNING: The warnings, cautions, and instructions discussed in this instruction manual cannot cover all possible conditions or situations that could occur.** It is understood and agreed by the operator that common sense and caution are factors that cannot be built into this product. It is the operator's responsibility to adhere to the instructions and operating procedures described in this manual to successfully operate this product.

## IMPORTANT SAFETY CONSIDERATIONS

To maintain the product and user safety, you must: -.

- Always check for damaged or worn-out parts before using the hoist. Broken parts will affect the equipment operation. Replace or repair damaged or worn parts immediately.
- Not modify the product in any way. Unauthorized modification may impair the function and/or safety and could affect the life of the equipment.
- Keep instructions readily available for equipment operators.
- Make certain all operators understand how to operate the unit safely and correctly.
- Allow unit operation only with all parts in place and operating properly.
- Use only genuine replacement parts.
- Service and maintain the unit only with authorized or approved replacement parts; negligence will make the product unsafe for use and void the warranty.
- Carefully inspect the unit on a regular basis and perform all maintenance as required.
- Keep all decals on the unit clean and visible.

## HAZARD DESCRIPTIONS

Identify the hazard levels used in this manual with the following definitions and signal words:

 **DANGER:**

Immediate hazards which will result in severe liability or exposure to personal injury or death.

 **WARNING:**

Hazards or unsafe practices which could result in severe personal injury or death.

 **CAUTION:**

Hazards or unsafe practices which may result in personal injury, product or property damage.

## SAFETY MARKINGS

Pay close attention and follow all the safety markings.

- Do not exceed rated capacity.
- Do not move or dolly the vehicle while on the hoist.
- Lift only on areas of any vehicle as specified by the vehicle manufacturer.
- No alterations shall be made to this product.
- Only attachments and/or adapters supplied by the manufacturer shall be used.
- Do not get under or allow anyone under the vehicle until it has been supported with auxiliary jack stands on both the front and rear of the vehicle.
- Center load on lifting arms and saddles prior to lifting.
- Secure vehicle to ensure no shifting, movement, or tipping will occur when performing maintenance on any vehicle.
- Verify that safety locks are engaged on the arms and lifting carriages before performing any work.
- Do not use this product for any use other than the manufacturer specified usage. Failure to heed these warnings may result in personal injury and/or property damage.



**WARNING:**

**DO NOT USE** wooden blocks or any other non-approved load sustaining devices or any other non-approved lifting devices for a means of lifting a vehicle or load being raised. The manufacturer only warrants loads to be sustained by adapters or accessories validated by the manufacturer. Failure to heed these warnings may cause injury or death.



## **GENERAL OPERATOR SAFETY INSTRUCTIONS:**

### **TRAINING**

Do not allow anyone who has not read this operating manual, and/or does not understand the requirements to use the product.

### **BYSTANDERS**

Keep all bystanders away from hoist when in use. Do not allow bystanders under the load supported. Do not allow anyone within a vehicle while the hoist is in use or is supporting a load.

### **OPERATORS**

Not for use by children or people with reduced mental capacity. Do not use under the influence of any drugs or alcohol.

### **INSPECTION**

Inspect the product carefully before each use. Ensure the product is not damaged, excessively worn, or missing parts. Do not use the hoist unless it is properly lubricated. Using a hoist that is not in good clean working condition or properly lubricated may cause serious injury.

### **INTENDED USE**

This two-post car hoist is designed to lift and raise light duty vehicles up to 4500kgs.

## GENERAL OPERATION

**USE THE HOIST CORRECTLY AND IN A PROPER MANNER.** Never use lifting adapters other than what has been supplied by the manufacturer.

- Positioning the vehicle is very important. Only people trained in operating the hoist should position the vehicle on the hoist. Never allow anyone to stand in the path of the vehicle as it is being positioned.
- Some vehicle maintenance and repair activities may cause the vehicle to shift. Follow the manufacturer's guidelines when performing these operations.
- The use of jack stands, or alternate lifting points may be required when completing some repairs for additional security. Special care must be used when lifting light duty trucks. Optional truck adapters may be required for each manufacturer's recommended lifting points.
- Always use these lifting points – (see lifting point guidelines). Running boards and other installed accessories may also require optional adapters.
- Ensure vehicle is balanced, failure to do so can cause injury and/or death.
- Removal or installation of heavier parts can change the vehicle's center of gravity on the hoist resulting in a critical load shift. The vehicle may then be unstable. Plan ahead for this possibility to ensure continued safety and refer to the vehicle manufacturers' service manual for recommended procedures.
- **DO NOT** remove any heavy component from vehicle that may cause excessive weight shift.
- **ALWAYS** keep the hoist area free of obstructions and debris.
- **NEVER** raise a vehicle with passengers inside.
- Before lowering a vehicle, check the hoist and surrounding area and remove all obstructions.
- Before removing the vehicle from the hoist, position arms to the drive through position and confirm an unobstructed exit.
- **ALWAYS** Make sure the vehicle's center of gravity is always safe before raising the vehicle. All points of contact on vehicles should always be double checked. Always make sure the vehicle is secure before lifting using vehicle manufacturers' recommended lifting points.
- Large vehicles, such as limousines, RVs, and long wheelbase vehicles, may not be suitable for lifting on this equipment. Check with the vehicle manufacturer.
- **DO NOT** rock or shake the vehicle while on working on or around hoist.
- **VERIFY** that all safety latches are engaged and lowered on to the safety latch ladders before any attempt is made to work on or near vehicle.
- **NEVER** override self-operating hoist controls.
- **NEVER** remove any safety related components, parts or safety stickers from the hoist. Do not use the hoist if any safety related component or part is damaged or missing.
- **DO NOT** block open or override self-closing the hoist controls; they are designed to return to the "Off" or Neutral position when released.
- **DO NOT** remove or disable arm restraints.
- **DO NOT** hit or run over the hoist arms or adapters. This could damage the hoist or vehicle. Before driving the vehicle into hoist bay, position arms and adapters to provide unobstructed entrance onto the hoist.

- **USE THE HOIST ONLY AS DESCRIBED IN THIS MANUAL.**
- Use only manufacturer's recommended attachments.
- The troubleshooting and maintenance procedures described in this manual can be done by the hoist's owner. Any other procedure should only be performed by trained hoist service personnel. These restricted procedures include, but are not limited to, the following: **cylinder replacement, carriage and safety latch replacement, arm replacement, overhead structure replacement, or electrical troubleshooting/repair.**
- **PAY ATTENTION** when walking under a vehicle that is raised on the vehicle hoist.



**DANGERS:**

- To reduce the risk of personal injury, keep hair, loose clothing, fingers, and all body parts away from moving parts.
- This equipment has internal arcing or sparking parts. To reduce the risk of electric shock the motor and hoist should not be exposed to moisture or water.
- To reduce the risk of fire, do not operate equipment in the proximity of open containers containing flammable liquids (example: Gasoline, flammable solvents).
- Anyone who will be in the vicinity of the hoist when it is in use should familiarize themselves with all the **Caution, Warning, and Safety** related decals supplied with this hoist and replace them if they are illegible or missing.

# SAFETY STICKER IDENTIFICATION

Below are the Safety Sticker identifications and markings that are on the hoist. These identifications are put in place to help with your safety and the safety of others. Always use caution when working around the vehicle hoist.

Please maintain these Safety Marking so safe operating practices can be maintained by each operator.

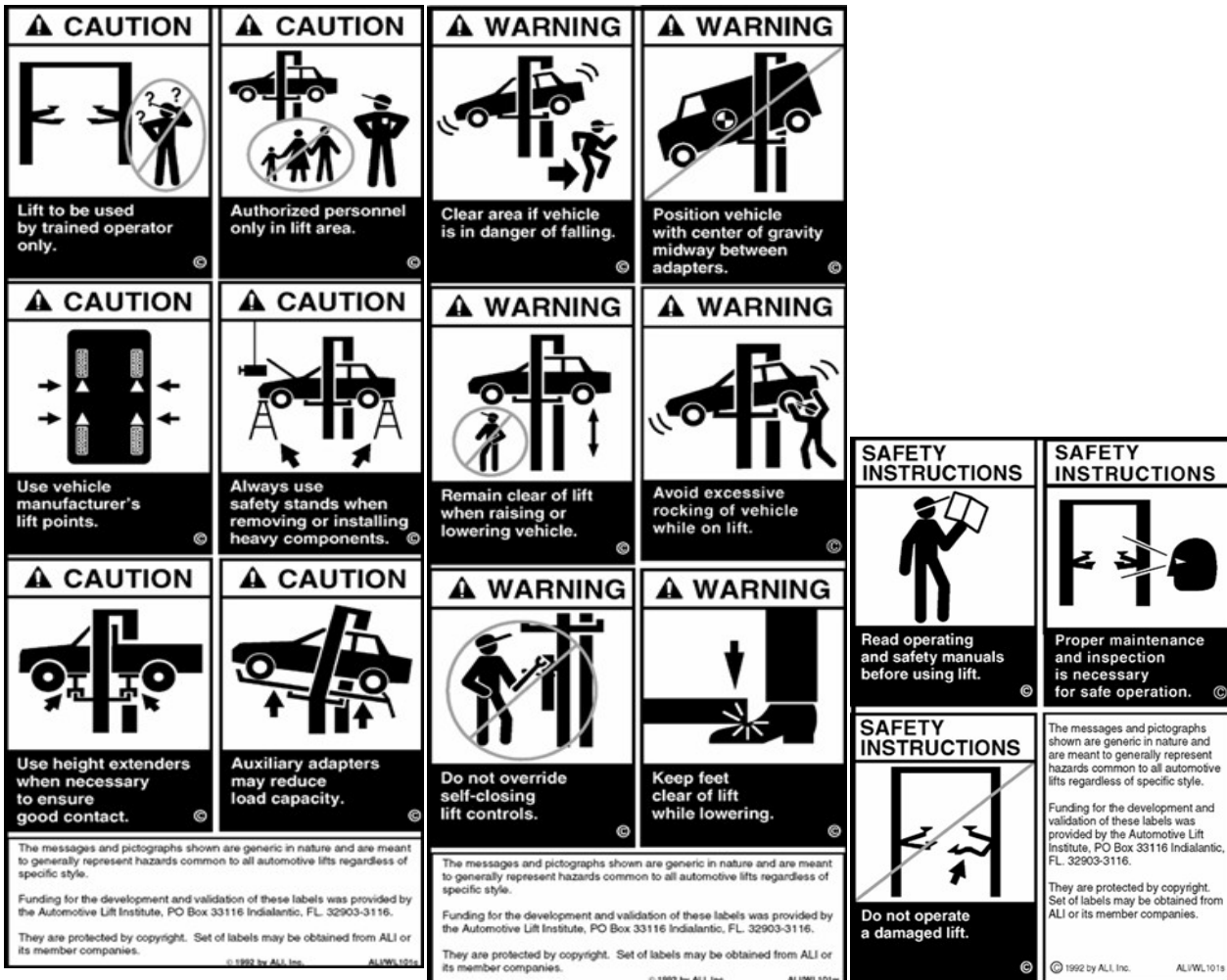



## HOW TO OPERATE THE HOIST

- **ONLY AUTHORIZED PERSONNEL** should operate the hoist.
- Make sure all operators have been trained and have reviewed the **OPERATOR AND SAFE PRACTICES** of this manual before using the hoist.
- Do not allow customers/friends/children or unauthorized personnel to operate the hoist or remain in the surrounding area during use.
- Familiarize yourself with the **Safety Precautions** to be followed when operating this hoist.
- Always allow a minimum 2-second delay between motor starts. Failure to comply may cause the switch and/or motor to burn out. This could cause serious damage to the equipment and/or personal property.
- Use only recommended ISO AW32 or AW46 hydraulic oils. Oil must be changed after the first week of operation and once every 12 months or as needed. Add extra oil as needed.
- Have a complete understanding of the carriage safety lock mechanisms.
  - The “**LOCKED position**” will be used when raising the hoist. This function should always work automatically.
  - The “**UN-LOCKED position**” will be used when lowering the hoist to the ground or adjusting the arm position.
- **Note: DO NOT** remove or tamper with the design of the locking assembly.
- *Failure to use locks as designed or forcing a lock to stay in the open position during use will be grounds for immediate termination of any warranty.*
- **ALWAYS** ensure the safety is engaged before any attempt is made to work under, on or near the vehicle.
- **NEVER** leave the hoist in elevated position unless the safeties are engaged.
- **NEVER** operate the hoist (up or down) with any person or equipment below the vehicle.
- **NEVER** exceed the rated lifting capacity.
- **DO NOT ALLOW THE ELECTRIC MOTOR TO GET WET!** Motor damage caused by dampness is not covered under warranty.
- **NEVER** lift any vehicle in any manner with less than all four (4) arms. The rated capacity of each lifting arm is no greater than one fourth (1/4) of the overall lifting capacity.
- **ALWAYS** position lifting arms, adapters and accessories properly out of the way before pulling the vehicle into or out of the bay. Failure to do so could damage the vehicle and/or the hoist.
- After positioning the vehicle, set the emergency brake (Hand Brake), make sure the ignition is off, the doors are closed, and overhead obstructions are cleared.
- Make sure the vehicle is not front or rear heavy. The center of balance should be in the middle of the columns.

### **DANGER:**

DO NOT RAISE OR LOWER ANY VEHICLE UNLESS TOOLS, MATERIALS AND PEOPLE ARE CLEAR. CLEAN UP GREASE AND OIL SPILLS IMMEDIATELY. When the hoist is being lowered, make sure everyone is standing at least six feet away. Always lower the vehicle down when the area is safe and clear.

### **DANGER:**

Check that the “half-moon” gear restraints on each lifting arm are engaged. Check for proper engagement of the

arm restraints (arm locks) before raising a vehicle. The safety gear restraints should fully engage the gear restraints on the arm automatically. **Note:** Regularly verify that Allen Bolts on gear restraints are tight and secure.

**IMPORTANT NOTE:**

Many specialty or modified vehicles cannot be raised on a two-post frame engaging hoist. Contact YOUR vehicle manufacturer for raising or jacking details.

**ALWAYS** load vehicle on hoist carefully. Position the lifting arms, adapters, and pads to the vehicle manufacturer's recommended pickup points. Raise the hoist until contact is made with the vehicle. Make sure that the lifting arms, adapters, and pads have properly engaged the vehicle before raising the hoist to a working height.

## DESCRIPTION OF LIFT CONTROLS

Description:	Purpose:
Safety Lock Lever	Used to release safety latches when lowering vehicle. -
Power "ON" Button	Controls electrical power to the hydraulic power unit. Push to turn-on.
Lowering Handle	Used to relieve hydraulic pressure when pressed to lower lifting carriages.
Fill Cap	Power unit fill Cap for the power unit fluid reservoir. Remove to add fluid.
Tank	Used to store hydraulic fluid.

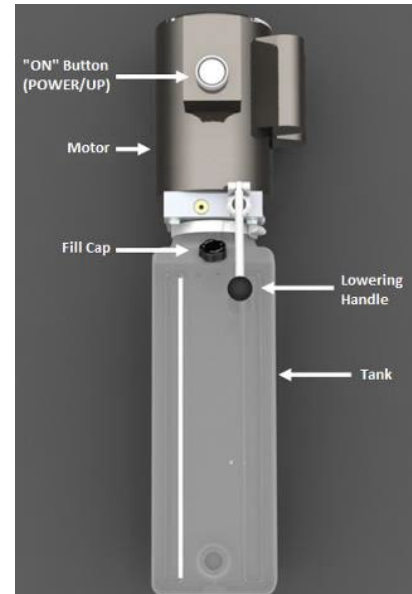

## CARRIAGE LOCK CONTROLS

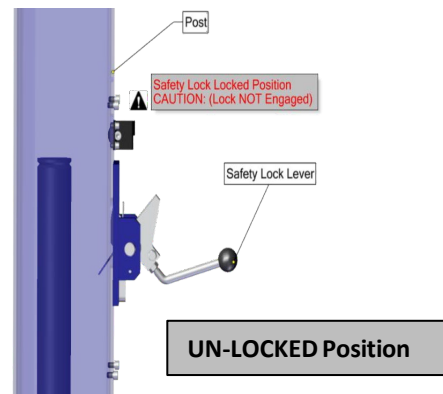
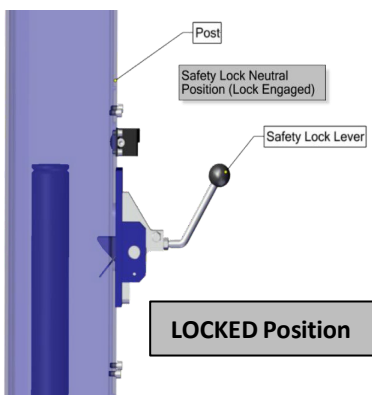

Following the review of these instructions, practice using the lift controls by running the lift through a few unloaded cycles prior to loading a vehicle onto the hoist. Always use all four [4] arms and adaptors when raising or lowering a vehicle. NEVER RAISE ONE END ONE CORNER OR ONE SIDE OF A VEHICLE.

## LOADING THE HOIST

**IMPORTANT NOTE:** Some vehicles may have the manufacturer's Service Garage Lifting Point locations identified by triangle shape marks on the undercarriage (reference ANSI/SAE J2184-1992). Additionally, there may be a label located on the right (driver side) front door jamb area showing specific vehicle lifting points.

**PRIOR TO LIFTING:** The hoist must be fully lowered, and the service bay clean of all personnel and equipment before the vehicle is brought on the lift. The swing arms must be set to the full drive through position.

**LOADING:** Move vehicle into the hoist bay. Swing arms under vehicle and position adaptors at the vehicle manufacturer's recommended lifting points – see diagrams. Use height extenders or optional frame cradle adaptors when necessary to ensure good contact.

To load the vehicle onto the hoist, use all four [4] arms making sure the vehicle is positioned correctly so all four corners of vehicle are stationary with wheel stops.

Position all lifting pads to contact vehicle at the manufacturer's recommended lifting points for proper weight distribution.

Raise the arms to just below the vehicle, stopping before making contact. Check arm restraint pin for engagement. If required slightly move the arm to allow restraint gear to mesh. Do not hammer arm restraint pin down as this will damage the restraint gear teeth.

Raise the hoist slowly until all pads contact the vehicle. Check all pads for complete and secure contact with the vehicle. Check all arm restraints to insure they are engaged properly. Check that the vehicle is stable on the hoist.

Raise the vehicle until the tires clear the floor. Stop and again check all adaptors for secure contact at the vehicle manufacturer's recommended lift points.

DO not go near or under a raised vehicle if all 4 adaptors are not in secure contact with the vehicle at the vehicle manufacturer's recommended lift points. Repeat the entire loading and raising procedure again.

Only after confirming these procedures, raise the hoist to desired working height.

MANY SPECIALTY OR MODIFIED VEHICLES CANNOT BE RAISED ON A TWO-POST FRAME ENGAGING LIFT. CONTACT VEHICLE MANUFACTURER FOR RAISING OR JACKING DETAILS

### RECOMMENDED LIFTING POINTS

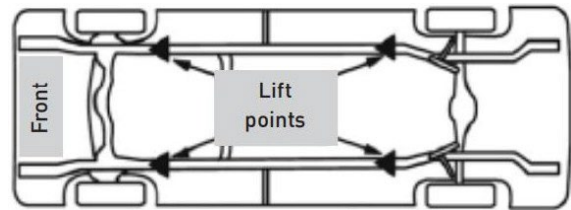

### Pick up truck / Van

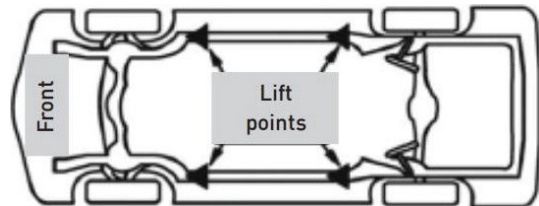

### Perimeter Frame

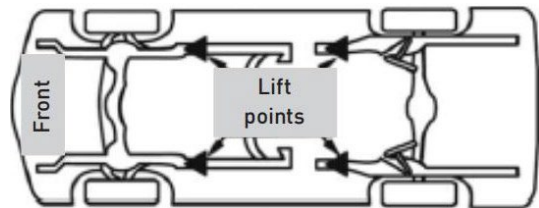

### Stub frame

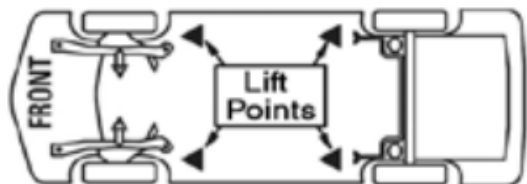

### Unitized Body

## RAISING THE HOIST,

- Prior to raising any vehicle, ensure the vehicle's is positioned at best to its center of gravity. Double check that all points of the lifting pads have contact on the vehicle. Always make sure the vehicle is secure before lifting using only your vehicle manufacturers' recommended lifting points.
  - Adjust the lifting arms so that the vehicle is positioned with the center of gravity midway between the hoist columns. (Use truck adapters as needed.)
-  **DANGER: NEVER** use the lifting pad assemblies without the rubber pads in place.

- Press the power "on" button.
- As the hoist rises a clicking sound will be heard. These are the carriage locks that will securely hold a vehicle.
- Once the desired height has been achieved slightly raise the carriage a little more, so the lift arms are just above the last latch position, (confirmed by the clicking sound) then slowly lower the load on the safety locks.
- **NEVER** attempt to raise the hoist by continually pressing the 'on' button in short bursts. This will cause critical damage to the hydraulic system, that could cause hydraulic failure.
- Verify that both Safety Carriage locks have been engaged before beginning work.

## TO LOWER THE HOIST,

- Prior to lowering the hoist
  - Always remove tool trays, stands and any other equipment that may cause obstruction.
  - Always release safety locks before attempting to lower the hoist.
  - Always position the hoist arms and adaptors to provide an unobstructed exit before removing the vehicle from the area.
- To lower the hoist, first raise the hoist to clear the safety latches, press the power "on" button, then pull down the safety release handle to lower the hoist. The carriages should now be in the free UN- LOCKED position.
- Simultaneously hold the Safety Carriage Locks in the UN-LOCKED Position and press the lowering control valve on the power unit.
- Lower the hoist slowly until reach the lowest retracted position.
- Retract the lifting arms to the shortest position.
- Place any arm extension adapters on column storage brackets.

WHEN LOWERING THE LIFT PAY CAREFUL ATENTION THAT ALL PERSONNEL AND OBJECTS ARE KEPT CLEAR.

ALWAYS KEEP A VISUAL LINE OF SITE ON THE LIFT AT ALL TIMES. ALWAYS MAKE SURE THAT ALL LOCKS ARE DISENGAGED. IF ONE OF THE LOCKS INADVERTENTLY LOCKS ON DESCENT THE LIFT AND/OR VEHICLE MAY DISRUPT CAUSING PERSONAL INJURY OR DEATH

# WEEKLY MAINTENANCE INSPECTION RECORD

DATE: \_\_\_/\_\_\_/\_\_\_

Mark OK for all Items in good working order.

	Lubricate posts with grease. Lubricate the four inside corners of the columns with heavy-duty bearing grease as needed.
	Inspect lifting arms making sure they are functioning properly.
	Visually inspect safeties for proper operation. Check all arm adjusting locks for proper operation.
	Inspect all arms pins making sure they are properly secure.
	Inspect that arm pads are in good condition, replace if worn.
	If the hoist is equipped with an overhead stop bar, check for proper operation.
	Check that all posts are square and plumb.
	Check equalizer cable tension, and adjust if necessary, see manual instructions. Lubricate Cable Sheaves.
	Check all cables connections, bolts and pins to ensure proper mounting and torque.
	Check safety latch synchronization: Safety latches should click at the same time. If necessary, adjust equalizing cables as described in the Installation Instruction section of this manual.
	Check tightness of all bolts and hardware. Re-tighten as needed. See installation manual torque specified ratings.
	Inspect all anchors bolts and retighten if necessary. Re-torque as needed. See installation manual for instructions.
	Make a visual inspection of all moving parts and check for excessive signs of wear.
	With the hoist in the lowered position, check the hydraulic fluid level. If needed, add oil as described in the Installation Instruction section of this manual.
	Check all warning labels and power unit safety stickers are in good condition. Replace all caution, warning or safety related decals on the lift if unable to read or missing. Reorder labels from manufacturer.



NOTES: \_\_\_\_\_

PRINT COPY PAGES FOR DAILY RECORDS

## WIRE ROPE INSPECTION MAINTENANCE



**Know when to replace your cables!** The pictures below will help you assess when you will need to replace wire rope. For Additional Information see “Wire Rope User’s Manual 4<sup>th</sup> Ed.”.

All wire rope, sheaves and guide rollers in continuous service should be observed during normal operation and visually as per the scheduled maintenance. A complete and thorough inspection of all ropes in use must be made as below and all rope which has been idle for a period of a month or more should be given a thorough inspection before it is put back into service. Factors such as abrasion, wear, fatigue, corrosion, improper winding and kinking are often of greater significance in determining if a wire rope is usable. Use the pictures as shown as guide for determining when to replace your wire rope.

### Recommended Lubrication Product:

A high-grade penetrating lubricant for wire rope, chain and cable that contain a petroleum solvent that carry the lubricant into the core of the wire rope, then evaporates, leaving behind a heavy lubricating film to protect and lubricate each strand. A penetrating lubricant is essential in any lubrication program as most wire rope fails from the inside out.

**Check all guide rollers, sheaves and hardware that are in operational contact are visually checked for wear and lubrication.**

### HOW TO INSPECT WIRE ROPE?

- Relax the rope to a stationary position and move the pick-up points off the sheaves. Clean the surface of the rope with a cloth, this will allow you to see breaks. (Use a stiff wire brush, if necessary.)
- Flex the rope to expose any broken wires hidden in the channels between the strands.
- Visually check for any broken wires. One way to check for crown breaks is to run a cloth along the rope to check for possible snags.
- With an awl tool, probe between wires and strands and lift any wires that appear loose. Evidence of internal broken wires may require a more extensive rope examination. **(IF IN DOUBT REPLACE CABLES)**
- Check for layer-to-layer crushing or individual wires that may have been displaced from their normal position.
- Check Sheaves for deeply corrugated sheaves that may also be causing damage to wire ropes. Replace sheaves if needed.
- Replace wire rope if any failing condition is found.

- Equalizing and Lifting Cables should be replaced every three years when visible signs of damage are apparent. **DO NOT USE THE HOIST WITH DAMAGED OR WORN**

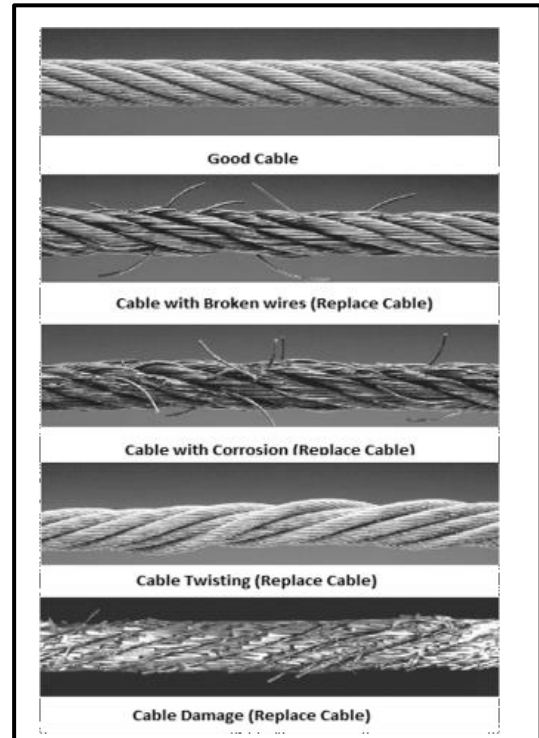

**CABLES.**

- A lubricant suited to the conditions under which the rope is operating should then be applied. Several methods are suggested, and the one most suited to the installation and lubricant being used may be chosen. It is better to lubricate lightly and frequently than heavily and infrequently. For best results lubricate to core of cables.
- **Check all guide rollers, sheaves and hardware that are in operational contact are visually checked for wear and lubrication.**
- **Visually Inspect and Apply lubricants to all contact points using a heavy weight lubricant using the methods as described: spray, pump, brush or hand lubrication.**

## TROUBLESHOOTING

### HOIST WILL NOT RAISE

Air is in the oil	<ul style="list-style-type: none"> <li>• Check for proper oil level. The oil level should be up to the bleed screw in the reservoir with the hoist all the way down.</li> <li>• Bleed cylinders. See Installation Manual</li> <li>• Oil seal damaged or cocked. Replace oil seal around pump shaft.</li> <li>• Inlet screen clogged. Clean inlet screen or replace</li> </ul>
Cylinder is binding	<ul style="list-style-type: none"> <li>• Contact Customer Service.</li> </ul>
Cylinder leaks internally	<ul style="list-style-type: none"> <li>• Contact Customer Service</li> </ul>
Hoist does not raise and lower smoothly	<ul style="list-style-type: none"> <li>• Reposition vehicle for a more even weight distribution.</li> <li>• Check the four inside corners of the two columns for roughness. Any rust or burrs must be removed with emery cloth.</li> <li>• Lubricate the four corners with heavy duty bearing grease.</li> <li>• Use a level to check the columns for vertical alignment both side to side and front to back. Shim the columns as necessary per the Installation Instruction section of this manual.</li> <li>• Check the oil level.</li> <li>• Inspect that there is no air in the hydraulic lines. Bleed the hydraulic system as described in the Installation Instruction section of this manual.</li> </ul>
Lowering valve is leaking	<ul style="list-style-type: none"> <li>• Contact Customer Service</li> </ul>
Motor runs backwards	<ul style="list-style-type: none"> <li>• Check if the motor is wired correctly. Compare wiring of motor to electrical diagram on drawing.</li> <li>• Check wall outlet voltages and wiring. Make sure unit and wall outlet are wired properly.</li> <li>• Contact Customer Service</li> </ul>
Motor run backward under pressure	<ul style="list-style-type: none"> <li>• Contact Customer Service</li> </ul>
Power Unit will not stop running	<ul style="list-style-type: none"> <li>• The switch is damaged. Turn off power to the hoist and replace switch</li> </ul>
Pump is damaged	<ul style="list-style-type: none"> <li>• Contact Customer Service</li> </ul>
Pump will not prime	<ul style="list-style-type: none"> <li>• Check for proper oil level. The oil level should be up to the bleed screw in the reservoir with the hoist all the way down.</li> <li>• Flush release valve in case jammed open. Hold release handle down and start unit allowing possible contamination to be flushed out, run for 15 seconds.</li> <li>• Oil seal damaged or cocked. Replace oil seal around pump shaft.</li> <li>• Replace with new part.</li> <li>• Check pump-mounting bolts. Bolts should be 15 to 18 ft. lbs.</li> <li>• Inlet screen clogged. Clean inlet screen or replace.</li> <li>• Check wall outlet voltages and wiring. Make sure the unit and wall outlet are wired properly.</li> <li>• Contact Customer Service</li> </ul>
Relief valve leaks	<ul style="list-style-type: none"> <li>• Contact Customer Service</li> </ul>
Voltage to the motor is incorrect	<ul style="list-style-type: none"> <li>• Check if the motor is wired correctly. Compare wiring of motor to electrical diagram on drawing.</li> <li>• Check wall outlet voltages and wiring. Make sure the unit and wall outlet are wired properly.</li> <li>• Contact Customer Service</li> </ul>
The power unit does not run	<ul style="list-style-type: none"> <li>• Check electrical supply breaker or fuse.</li> <li>• Check to see if the limit switch is being contacted by a tall vehicle.</li> <li>• Check micro-switch and connections in motor control box.</li> <li>• Check voltage to the motor.</li> <li>• Check micro-switch and connections on the overhead switch</li> </ul>
The power unit runs but does not raise the hoist	<ul style="list-style-type: none"> <li>• Check the oil level.</li> <li>• Check that the lowering valve is not stuck open.</li> <li>• Check the connections and components on the suction side of the pump</li> </ul>
The power unit raises the hoist empty but will not lift a vehicle	<ul style="list-style-type: none"> <li>• Make sure the vehicle is not above the rated capacity of the hoist.</li> <li>• Make sure the vehicle is positioned properly.</li> <li>• Clean the lowering valve by running the power unit for 15 seconds while holding the lowering valve open.</li> <li>• Check the motor voltage</li> </ul>



## TROUBLESHOOTING

### MOTOR WILL NOT RUN

	Fuse is blown	<ul style="list-style-type: none"> <li>• Check for correct voltage. Compare supply voltage with voltage on motor name tag. Check that the wire is sized correctly. Requires 2.5mm<sup>2</sup> for 20 Amps.</li> <li>• Check motor is wired correctly. Compare wiring of motor to electrical diagram on drawing.</li> <li>• Don't use extension cords. The size of the conductors should be such that the voltage drop would not exceed 3% to the farthest outlet for power.</li> <li>• Reset circuit breaker/fuse. Reset circuit breaker/fuse.</li> <li>• Contact Customer Service.</li> </ul>
	Limit switch is burned out	<ul style="list-style-type: none"> <li>• Check for correct voltage. Compare supply voltage with voltage on motor name tag. Check that the wire is sized correctly. Requires 2.5mm<sup>2</sup> for 20 Amps.</li> <li>• Check the motor is wired correctly. Compare wiring of motor to electrical diagram on drawing.</li> <li>• Don't use extension cords. The size of the conductors should be such that the voltage drop would not exceed 3% to the farthest outlet for power.</li> <li>• Contact Customer Service.</li> </ul>
	Switch is burned out	<ul style="list-style-type: none"> <li>• Check for correct voltage. Compare supply voltage with voltage on motor name tag. Check that the wire is sized correctly. Requires 2.5mm<sup>2</sup> for 20 Amps.</li> <li>• Check the motor is wired correctly. Compare wiring of motor to electrical diagram on drawing.</li> <li>• Don't use extension cords. The size of the conductors should be such that the voltage drop would not exceed 3% to the farthest outlet for power.</li> <li>• Contact Customer Service.</li> </ul>
	Motor is burned out	<ul style="list-style-type: none"> <li>• Check for correct voltage. Compare supply voltage with voltage on motor name tag. Check that the wire is sized correctly. Requires 2.5mm<sup>2</sup> for 20 Amps.</li> <li>• Check the motor is wired correctly. Compare wiring of motor to electrical diagram on drawing.</li> <li>• Don't use extension cords. The size of the conductors should be such that the voltage drop would not exceed 3% to the farthest outlet for power.</li> <li>• Replace it with a new part.</li> <li>• Contact Customer Service</li> </ul>
	Voltage to the motor is not correct	<ul style="list-style-type: none"> <li>• Check for correct voltage. Compare supply voltage with voltage on motor name tag. Check that the wire is sized correctly. Requires 2.5mm<sup>2</sup> for 20 Amps.</li> <li>• Check motor is wired correctly. Compare wiring of motor to electrical diagram on drawing.</li> <li>• Check wall outlet voltage and wiring. Make sure unit and wall outlet is wired properly. Motor must run at 220-240 VAC.</li> </ul>

**⚠ DANGER:**

**IF A VEHICLE BECOMES STUCK ON THE HOIST IN THE AIR, FOLLOW ALL OPERATION INSTRUCTIONS AS SHOWN IN THE OPERATING INSTRUCTIONS AND TROUBLESHOOTING SECTION OF THIS MANUAL. IF AFTER OBSERVING THAT ALL MECHANICAL LOCKS ARE RELEASED AND THE HOIST STILL FAILS TO MOVE FOLLOWING ALL STANDARD OPERATING PROCEDURES, IMMEDIATELY STOP USING THE HOIST AND CONTACT CUSTOMER SERVICE FOR FURTHER INSTRUCTIONS.**

# GENERAL ASSEMBLY DIAGRAM

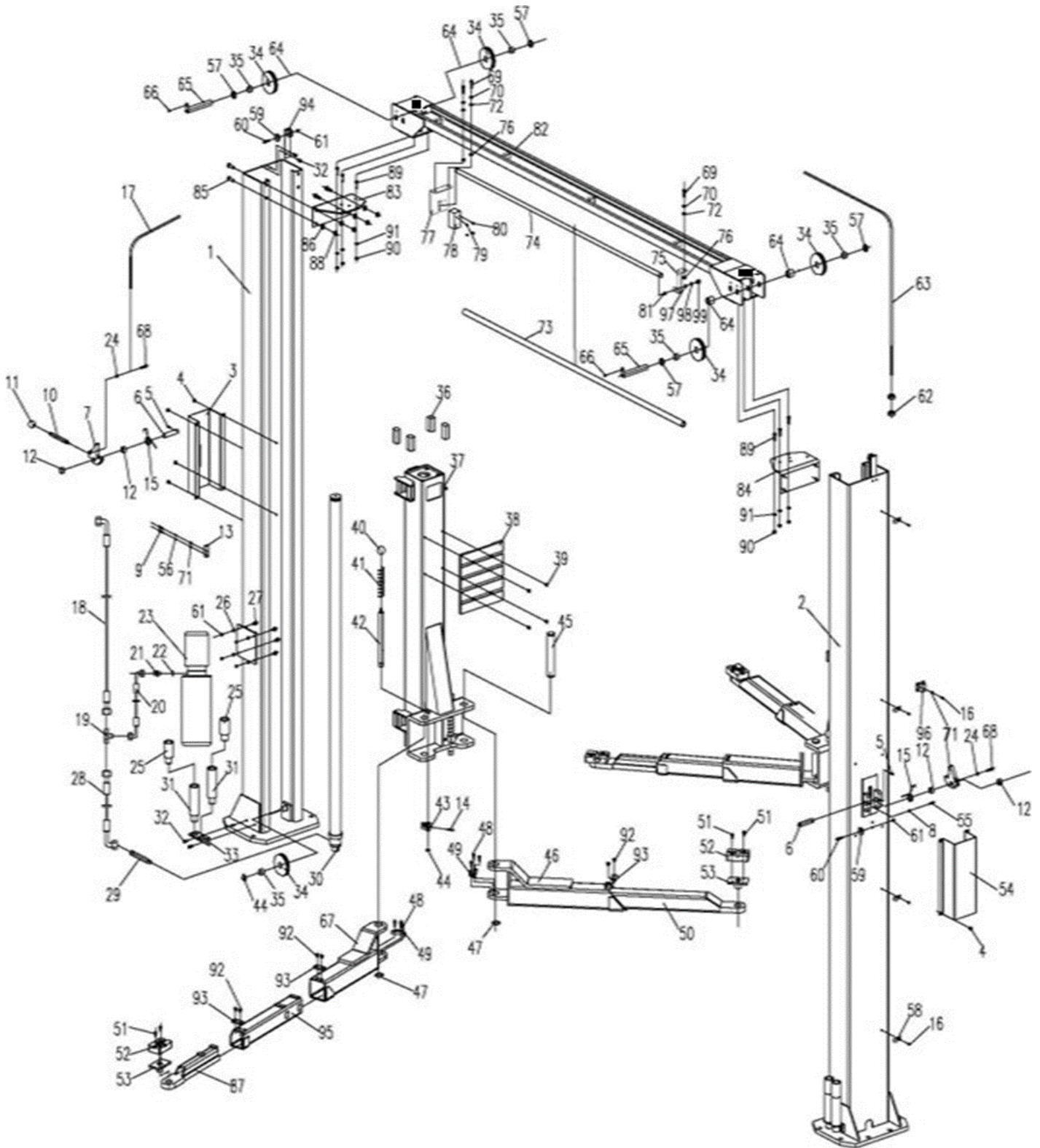

## GENERAL ASSEMBLY PARTS LIST

1	QJY245DS.1	COLUMN POWER SIDE (PS) ASSEMBLY	1	51	GB/T 70.1-2000	HW SOCKET HEAD CAP SCREW M8 X 12	8
2	QJY245DS.2	COLUMN OFF-SIDE (OS) ASSEMBLY	1	52	QJY230C.4-03	RUBBER LIFT PAD	4
3	QJY245DS-13	SAFETY COVER POWER SIDE	1	53	QJY230CY.4.3	ARM LIFT PAD WELDMENT	4
4	GB 818	HW MACHINE SCREW PAN HEAD - PHILLIPS DRIVE M8 X 10	8	54	QJY245DS-14	SAFETY COVER OFF-SIDE	1
5	GB 71	HW CUP POINT ALLEN HEAD SOCKET SET SCREW M10 X 12	2	55	GB 5781	HW HEX HEAD CAP SCREW M6 X 20	1
6	QJY245DS-06	SAFETY PIN	2	56	GB 93	HW SPRING LOCK WASHER M6	2
7	QJY245DS-09	SAFETY HOOK	2	57	QJY230D.3-05	TIE BAR SPACER 26mm X 11	4
8	GB 6170 M6	HW HEX NUT M6	1	58	QJY230D-02	COLUMN CLIP HOSE AND ELECTRICAL	8
9	GB 5781	HW HEX HEAD CAP SCREW M6 X 30	2	59	QJY245DS-03	SHEAVE SAFETY CABLE 32mm	4
10	QJY245DS-10	SAFETY LEVER	1	60	GB 70.1	HW SOCKET HEAD CAP SCREW M8 X 30	4
11	GB84141.11-84	HW HANDLE BALL (SAFETY) M10 X 25	1	61	GB 889 M8	HW NYLON-INSERT HEX LOCKNUT M8	8
12	QJY245DS-20	TIE BAR SPACER 20.5mm X 16.5	4	62	GB6170 M16	HW HEX NUT M16 (EQUALIZING CABLE)	8
13	QJY245DS-02	SAFETY HOOK LIMIT	1	63	QJY245DS-01	CABLE EQUALIZING ASSEMBLY DS (10260mm)	2
14	GB 879.1	HW SLOTTED SPING PIN (ROLL PIN) M5 X 35	4	64	QJY245DS.9-01	TIE BAR SPACER 26mm X 37	4
15	QJY245DS-07	SAFETY SPRING	2	65	QJY245DS.9.2	TIE BAR SHEAVE PIN DS	2
16	GB/T 70.1	HW SOCKET HEAD CAP SCREW M6 X 10	16	66	GB819	HW MACHINE SCREW FLAT HEAD - PHILLIPS DRIVE M6 X 10	2
17	QJY245DS.17	SAFETY CABLE ASSEMBLY DS/DA	1	67	QJY245DS-B.6a.1	BACK ARM ASSEMBLY (3 STAGE DS)	2
18	QJY245DS.8-04	HYDRAULIC HOSE ASSEMBLY 9220mm (DS)	1	68	GB5782	HW HEX HEAD CAP SCREW M8 X 35	2
19	QJY245DS.8-06	HYDRAULIC 37' COMPRESSION 9/16"-18 STEEL TEE FITTING	1	69	GB5783	SCREW M12X25	3
20	QJY245DS.8-03	HYDRAULIC HOSE ASSEMBLY 360mm (DS)	1	70	GB 93	HW SPRING LOCK WASHER M12	3
21	QJY245DS.8-05	HYDRAULIC SAE O-RING FITTING	1	71	GB97.1	HW FENDER WASHER M6	10
22	JB982-77	HYDRAULIC O-RING	1	72	GB97.1	HW FENDER WASHER M12	3
23	QJY230C.8-11	POWER UNIT	1	73	QJY245DX.9-03	TIE BAR SAFETY BAR FOAM PAD	1
24	GB6170	HW HEX NUT M8	2	74	QJY230DY.3-06	TIE BAR SAFETY BAR	1
25	QJY245DS-18	ARM PAD EXTENSION ADAPTER SHORT 75mm	4	75	QJY230DY.3-05	JUNCTION PLATE	1
26	GB97.1	HW FLAT WASHER M8	4	76	GB 6170	HW HEX NUT M12	3
27	GB5781	HW HEX HEAD CAP SCREW M8 X 22	4	77	QJY230DY.3-04	TIE BAR SAFETY SWITCH BRACKET	1
28	QJY245DS.8-02	HYDRAULIC HOSE ASSEMBLY 1040mm (DS)	1	78	QJY230C-XW.1-05	ELECTRONIC SAFETY SWITCH	1
29	QJY245DS.8-01	HYDRAULIC CYLINDER FITTING	2	79	GB 818	HW MACHINE SCREW PAN HEAD - PHILLIPS DRIVE M4X25	2
30	QJY245DS.7	HYDRAULIC CYLINDER 50mm X 1755mm (2 X 69)	2	80	GB 818	HW MACHINE SCREW PAN HEAD - PHILLIPS DRIVE M4X12	2
31	QJY245DS-05	ARM PAD EXTENSION ADAPTER LONG 150mm	4	81	GB 6170	HW HEX NUT M8	1
32	GB 70.1	HW SOCKET HEAD CAP SCREW M8 X 12	8	82	QJY245DS.9a.1	TIE BAR ASSEMBLY WELDMENT DS	1
33	QJY245DS-16	ADAPTER BRACKET (LIFT PAD EXTENSIONS)	2	83	QJY245DS.9-04	TIE BAR ADAPTER PLATE (PS)	1
34	QJY245DS-17	SHEAVE 110mm	6	84	QJY245DS.9-05	TIE BAR ADAPTER PLATE (OS)	1
35	SF-2	SHEAVE BRASS REDUCER BUSHING 25mm x 20	6	85	GB5783-86	HW HEX HEAD CAP SCREW 8.8 M12 X 35	8
36	QJY230C.2-03	CARRIAGE SLIDE BLOCKS	16	86	GB95-85	HW FLAT WASHER M12	8
37	QJY245DS.3	CARRIAGE ASSEMBLY	2	87	QJY245DA-B.6a.3	FRONT ARM ASSEMBLY (3 STAGE DS)	2
38	QJY230C.2-01	RUBBER GUARD	4	88	GB889.1	HW NYLON-INSERT HEX LOCKNUT M12	8
39	GB819-85	HW FLAT HEAD SOCKET HEAD CAP SCREW ALLOY STEEL M8 X 15	8	89	GB5781-86	HW HEX HEAD CAP SCREW M10 X 30	6
40	GB84141.11-84	HW HANDLE BALL (ARM LOCK) M12 X 30	4	90	GB889.1	HW NYLON-INSERT HEX LOCKNUT M10	6
41	QJY245DS.3-07	CARRIAGE RESTRAINT PIN SPRING	4	91	GB95-85	HW FLAT WASHER M10	6
42	QJY245DS.3-05	CARRIAGE RESTRAINT PIN (ARM LOCK)	4	92	GB/T 2673	HW FLAT HEAD SOCKET HEAD CAP BPT SCREW ALLOY M10 X 12	12
43	QJY230C.2-02	CARRIAGE GEAR RESTRAINT	4	93	QJY230C.4-02	ARM STOP	6
44	GB 894.1	HW EXTERNAL RETAINING RING 25mm	6	94	QJY245DX.15.1	SAFETY CABLE BRACKET DS	2
45	QJY245DS-04	ARM DROP PIN	4	95	QJY245DS-B.6a.2	MIDDLE ARM ASSEMBLY (3 STAGE DS)	2
46	QJY245DS.5a.2	BACK ARM ASSEMBLY (2 STAGE DS)	2	96	QJY245DS.1-02	SAFETY PULLEY SEAT	2
47	GB 894	HW EXTERNAL RETAINING RING M38	4	97	GB 93	HW SPRING LOCK WASHER M8	1
48	GB/T 70.1-2000	HW SOCKET HEAD CAP SCREW M10 X 20	12	98	GB97.1	HW FENDER WASHER M8	1
49	QJY230C.4-04	ARM GEAR RESTRAINT	4	99	GB 6170	HW HEX NUT M8	1
50	QJY245DS.5a.1	FRONT ARM ASSEMBLY (2 STAGE DS)	2	100			

*Joel's* **GARAGE GEAR**

[www.joelsgaragegear.com.au](http://www.joelsgaragegear.com.au)