

Joel's

GARAGE GEAR

INSTALLATION GUIDE/ OWNERS MANUAL



JGG-4PSTSTD

4000KG STANDARD 4 POST HOIST

CONTENT

TECHNICAL SPECIFICATIONS4

CONCRETE FOUNDATION SPECIFICATIONS AND REQUIREMENTS4

OWNER /INSTALLER RESPONSIBILITIES:..... 5

IMPORTANT INFORMATION:..... 5

SHIPPING DAMAGE/MISSING PARTS CLAIMS 5

LIMITATION OF LIBILITY 5

PRODUCT WARRANTY6

 WHAT IS NOT COVERED BY THE PRODUCT WARRANTLY6

INSTALLATION TOOLS REQUIRED:..... 7

PRE-INSTALLATION PROCEDURES 8

 SELECT LIFT LOCATION:..... 8

 FLOOR REQUIREMENTS: 8

 CEILING REQUIREMENTS: 8

 DEFECTIVE CONCRETE: 8

HOIST LOCATION LAYOUT9

 LAYOUT THE INSTALLATION AREA.9

CAR LIFT DIMENSIONS 10

CAR LIFT GENERAL ASSEMBLY COMPONENTS..... 11

INSTALLATION PROCEDURE..... 12

 UNPACKING THE HOIST 12

POSITION THE COLUMNS 13

INSTALL COLUMN CROSS BEAMS 14

INSTALL THE SAFETY LADDERS 14

INSTALL THE COLUMN CAPS 15

SETTING THE LADDER GAPS 15

SETTING THE PRIMARY SAFEY LOCKS 16

MOUNTING THE RUNWAYS ONTO THE CROSS BEAMS..... 17

 POWERSIDE INSTALLATION RUNWAY 17

 OFFSIDE RUNWAY INSTALLATION 18

CABLE & SHEAVE INSTALLATION 19

POWER UNIT LOCATION..... 21

INSTALL THE POWER UNIT 21

IMPORTANT POWER-UNIT INSTALLATION NOTES 21

INSTALL THE HYDRAULIC SYSTEM HOSES 22

FILLING THE POWER UNIT WITH HYDRAULIC OIL 24

CONNECTING THE AIR SOURCE TO THE SAFETY ACTUATORS 25

CONNECT ELECTRICAL TO THE POWER UNIT;..... 26

INSPECTING THE SLACK SAFETY SPRINGS 27

LEVELING THE RUNWAYS & ADJUSTING SAFETY CABLES..... 27

BLEEDING THE AIR FROM THE HYDRAULIC SYSTEM 27

INSTALLING THE RAMPS & WHEEL STOPS 28

FINAL ADJUSTMENTS & LIFT START UP 29

ANCHORING THE COLUMNS 30

 DRILLING NOTES FOR EXPANSION ANCHORS..... 31

 INSTALLING EXPANSION ANCHORS AND LEVELING THE COLUMNS 31

POST INSTALLATION PROCEDURE:..... 32

OPERATION MANUAL 33

OPERATOR TRAINING AND SAFE PRACTICES..... 34

GENERAL SAFETY RULES 34

IMPORTANT SAFETY CONSIDERATIONS 34

HAZARD DESCRIPTIONS 35

SAFETY MARKINGS 35

 TRAINING 36

 BYSTANDERS 36

 OPERATORS 36

 INSPECTION 36

INTENDED USE 36

GENERAL OPERATION 36

SAFETY STICKER IDENTIFICATION..... 38

HOW TO OPERATE THE HOIST 40

 IMPORTANT NOTE:

DESCRIPTION OF LIFT CONTROLS 42

LOADING A VEHICLE ON THE HOIST 43

RAISING THE HOIST WITH VEHICLE LOAD, 43

LOWERING THE HOIST WITH VEHICLE LOAD..... 43

WEEKLY MAINTENANCE INSPECTION RECORD DATE: 44

 NOTES: 44

WIRE ROPE INSPECTION MAINTENANCE 45

TROUBLESHOOTING 46

TROUBLESHOOTING 47

TECHNICAL SPECIFICATIONS

Description	Metric (mm) (kg)
Motor specs	240v 20a single phase
Clearance between posts	2715mm
Max table height	1900mm
Post height	2230mm
Overall width including pump	3300mm
Overall length not including ramps when down	4405mm
Overall length including ramps when down	5165mm
Table length	4055mm
Each table width	480mm
N.w/ g.w	770kgs/ 785kgs
Minimum concrete thickness	150mm
Material thickness	
Cables	10mm
Cross beams	6mm
Runways	5mm
Columns	4mm

CONCRETE FOUNDATION SPECIFICATIONS AND REQUIREMENTS

4-Post Hoist 4000kg. 120mm Min. Thickness / 32MPa, SL62 mesh.

Safe Operating Temperature is between 4°C - 41°C.



OWNER /INSTALLER RESPONSIBILITIES:

DO NOT PROCEED WITHOUT READING THIS MANUAL

It is vital that you carefully read and fully understand all **ASSEMBLY INSTRUCTIONS** before installing this product. Failure to follow the safety rules and basic safety precautions described and presented in this manual may result in serious personal injury including death.

If you have any questions or experience problems, please call our Customer Support department on **1800 563 574**, Monday-Friday. 8.30 a.m.- 4.30 p.m. Melbourne Time.

All repairs are only to be performed by authorised or qualified technicians.

By proceeding you acknowledge and agree that you will fully comprehend and understand the contents of this manual.

IMPORTANT INFORMATION:



WARNING: Do not allow other people to assemble this product until they have read this manual and have developed a thorough understanding of how the product works.

The **JGG-4PSTSTD, 4 Post Hoist Standard** (rated at 4000kg's) is designed for **indoor use only** and should not be installed in a pit or on an uneven surface. The floor on which the hoist is installed must have a **minimum thickness of 120mm concrete** substrate, reinforced with steel bar (SL62) with a minimum compressive strength of **32MPa**. (If you are unsure of this requirement, we strongly recommend you contact your builder or architect for information before installing on pre-stressed concrete.)

This hoist has specific electrical and physical height requirements as described in the installation section of this manual. **Failure by the owner to provide and meet the recommended shelter, mounting surface, electrical supply, and ceiling height can result in unsatisfactory hoist performance, property damage, personal injury or both. Failure to comply with these basic requirements will void any warranty on the product.**

SHIPPING DAMAGE/MISSING PARTS CLAIMS

Any freight damage or lost parts (where visible) must be noted on the freight bill before signing off and must be reported to Joel's Garage Gear to establish a freight claim. When unpacking the product carefully check that all components are provided – refer to the complete parts list provided at the end of this manual. If shortages are discovered, please contact Joel's Garage Gear immediately with a missing part/s list.

LIMITATION OF LIABILITY

The **manufacturer and Joel's Garage Gear** are not and will not be held responsible for any liability for loss, damages of any kind expressed or implied, injury, and or damage to your property or otherwise caused by improper installation, use of this product or neglect on your or the operators' actions.

PRODUCT WARRANTY

WHAT IS NOT COVERED BY THE PRODUCT WARRANTY

- Any failure that results from owner/operator abuse, neglect or failure to operate, maintain or service product in accordance with instructions provided in the owner's manual.
- Any damage caused by overloading lift beyond rated capacity.
- General service on a regular basis is required to maintain the product, i.e. lubricants, oil, etc.
- General wear-n-tear of parts such as rubber pads, lifting shoes, etc. unless wear or failure is a direct result of manufacturer defect due to material and/or workmanship.
- Any failure caused by installing or operating lift under conditions not in accordance with installation and operation guidelines or damaged by contact with tools or surroundings.
- Motor or pump failure caused by exposure to moisture/water, excessive humidity, corrosive environments or other contaminants.
- Rusted components due to improper maintenance or corrosive environments.
- Cosmetic defects that do not interfere with product functionality, such as scratched paint.
- Damage due to incorrect voltage or improper wiring.
- Any incidental, indirect, or consequential loss, damage or expense that may result from any defect, failure or malfunction of the product.

INSTALLATION TOOLS REQUIRED:

Please ensure you have all the necessary tools and equipment listed below to successfully complete the installation. **We recommend that you use safety protective clothing and eyewear when installing the hoist.**

- 8m. Measuring tape
- Chalk line and chalk or equivalent
- Heavy duty metal wire cutters
- 1mtr. Crowbar
- Full set of metric wrenches and ratchet set
- Full set Imperial wrenches and ratchet set
- Full set metric and Imperial Allen keys
- Calibrated Torque Wrench
- Hammer
- Rubber mallet
- Phillips screwdriver
- Flat blade screwdrivers
- Circlip pliers
- 2 x 3mtr. Step ladders
- 1m. Spirit Level
- Rotary hammer drill
- 16mm diameter masonry drill bit
- Lifting devices such as a crane or forklift*
- 100mm x 100mm wooden blocks (use for unpacking)
- Gloves
- Mobile phone with a camera
- *Additional help if no lifting devices available

PRE-INSTALLATION PROCEDURES

Before installation, check and confirm the following:

SELECT LIFT LOCATION:

Always use architects building plans when available. Check layout dimensions against floor plan requirements making sure that adequate space is available on both the sides and in height.

FLOOR REQUIREMENTS:

The hoist should be located on a level floor with less than **3 degrees' slope**. If unsure, consider a survey of the proposed location and/or the possibility of pouring a new level concrete slab. This hoist can only be installed on a concrete floor which conforms to the specifications detailed in this manual. Columns are supported only by anchoring to concrete floors. Failure to do so could cause personal injury or death. **DO NOT INSTALL** the hoist on asphalt. **DO NOT** locate this machine in a recessed area or below floor level. **ALLOW FOR ADEQUATE AND PROPER DRAINAGE.**

CEILING REQUIREMENTS:

The area where the hoist will be located should be free of overhead obstructions such as heaters, building supports, electrical lines, etc.

DEFECTIVE CONCRETE:

Visually inspect the site where the hoist will be installed and check for cracked or defective concrete. If the proposed location is in question, **DO NOT INSTALL THIS HOIST**. If you have any questions and concerns with the hoist location selected contact your local builder or architect. (*Note - A qualified person should be consulted to address seismic loads and other local or state requirements*)

JOEL'S GARAGE GEAR WILL NOT BE HELD RESPONSIBLE OR LIABLE FOR ANY CONCRETE THAT MAY OR MAY NOT MEET SLOPE REQUIREMENTS. IT IS COMPLETELY THE OWNER'S RESPONSIBILITY TO ENSURE THAT THE CORRECT SUBSTRATE FLOORING IS TO THE REQUIRED SPECIFICATIONS. JOEL'S GARAGE GEAR WILL NOT BE RESPONSIBLE FOR ANY CHARGES RELATING TO NEW CONCRETE SLABS POURING, LEVELING OR DAMAGE

HOIST LOCATION LAYOUT

Before any installation can occur, we recommend first completing a layout of the hoist location. The minimum bay size required (that is free unobstructed space) to install is 5005mm [L] x 3101mm [W] x 3000mm [H]

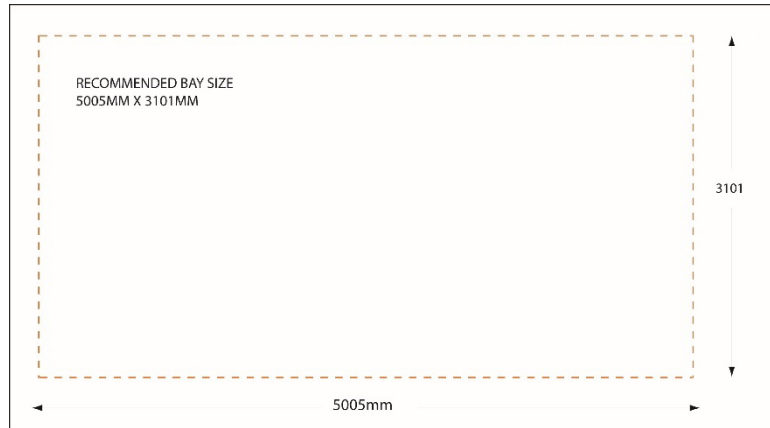

LAYOUT THE INSTALLATION AREA.

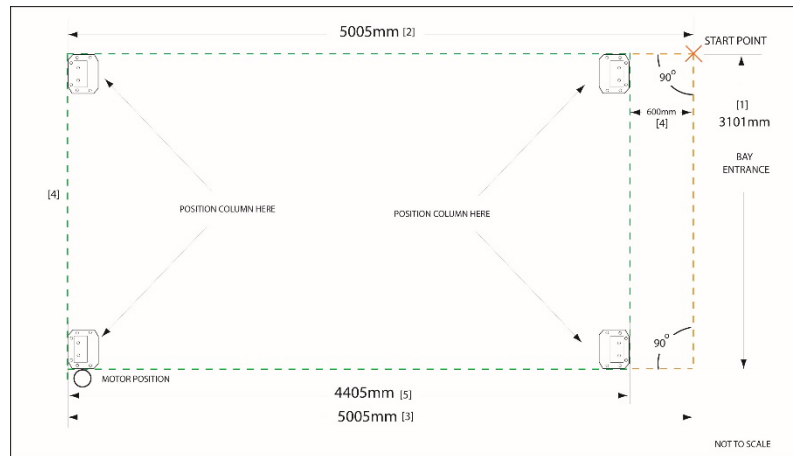

With measuring tape, start at one corner of the proposed area and mark a line (using tape or chalk) 3101mm [1] long. Typically this is across the entrance to the bay. (Note this start point should be at least 150mm from any side wall and 900 from the bay entrance) Working from the same start point, draw a line 90 degrees to the first line 5005mm [2] long down one side. Mark another 5005mm line [3] also at 90 degrees to the first line from the other end of the start line. At the end of both lines, draw another 3101mm [4] line that joins the two 5005 lines to complete a rectangle on the floor. (Use above diagram as reference)

Now to create the column positions, start at the opposite side to the Start Point, (Front of bay [4] line) and measure across both sides [2 & 3] 4405mm, mark it and join the two lines from top to bottom together. The corners of this rectangle are the positions where the hoist column uprights will be located. **Please note** It is strongly recommended that you allow additional space to allow easy access to the on/off ramps. Failure to allow sufficient distance will complicate the installation greatly.

CAR LIFT DIMENSIONS

Take note of the sizes of the internal opening of the hoist (2365mm). The following identifies the sizing of the bay area at the base on the hoist. Further note, that the runways can be set to a narrow or wide setting depending on the vehicle size.

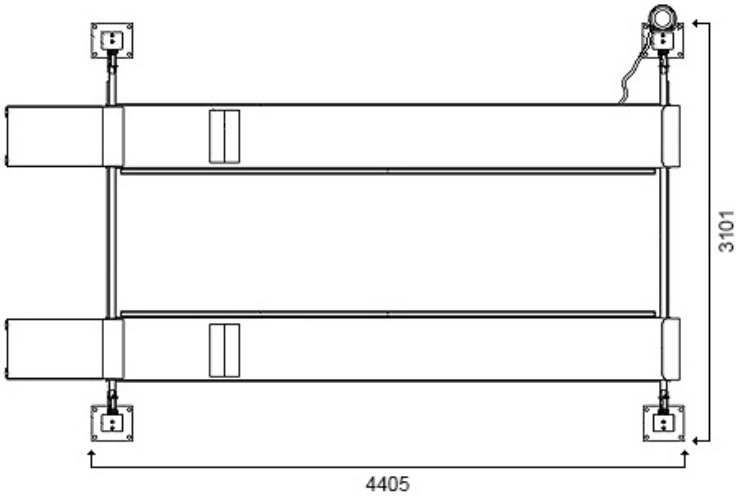
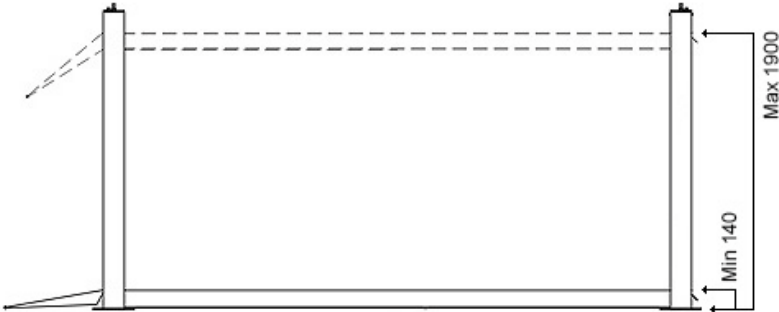
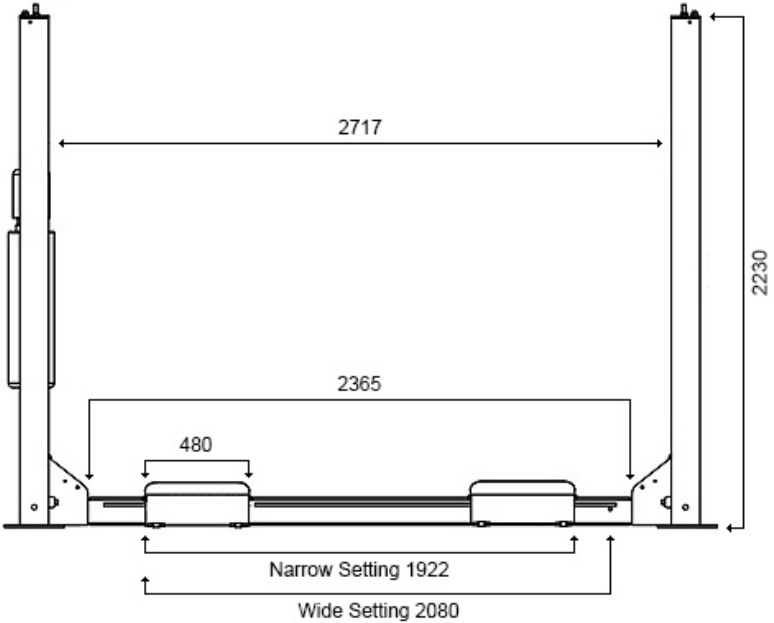

CAR LIFT GENERAL ASSEMBLY COMPONENTS

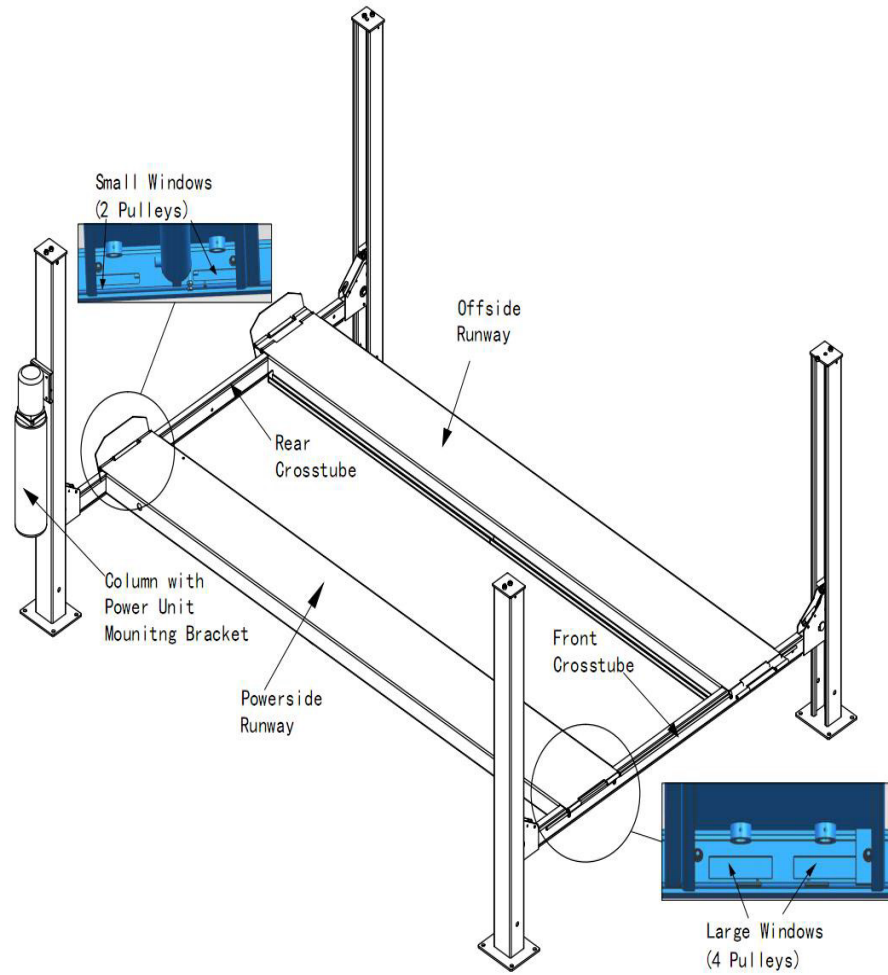

INSTALLATION PROCEDURE

If you are installing this hoist as a DIY install, it is strongly recommended that you have at least one (if not two) other person/s as extra help or have heavy duty lifting equipment when unloading and assembling the hoist. Never attempt to lift components without proper lifting tools such as sling bands, forklift or crane. Be aware and stay clear of any moving parts that can fall and cause injury.

UNPACKING THE HOIST

- When unloading the hoist, place it as near as possible to the intended installation location.
- The power unit package is located inside the hoist package. **Note:** The power unit is heavy, be careful not to drop the power unit. Place the power unit aside out of the way.
- Start by first removing the shipping bands and packing materials from the hoist. Open the wrapping, remove the parts and parts boxes from the packaging.
- Using the parts list contained check that all parts are accounted for. If **any parts are missing**, please advise Joel's Garage Gear immediately.
- Unbolt the structure from the shipping brackets. (Where available use proper lifting devices, cranes or a forklift to lift off shipping brackets.)

INSTALL COLUMN CROSS BEAMS

IMPORTANT NOTE: each cross beam is different and must be installed on the correct end and in a specific direction.

The cross beam with the small windows (show as sheave window) is installed on the same end as the column that will hold the power unit. (Front left-hand side). The cross beam with large windows needs to be on the opposite end. Both the cross beams should have their sheave windows facing each other for the cables to run through.

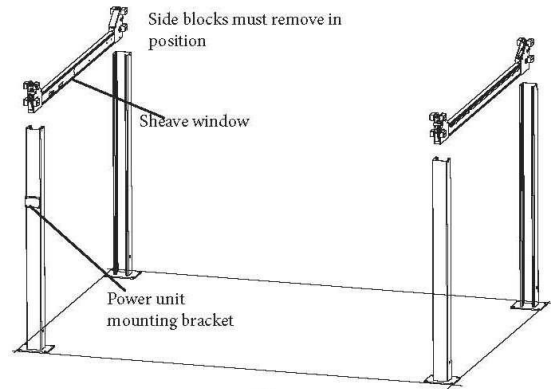

Working one end at a time, (with another person) carefully lay the two columns down so they are both laying on the ground. Check to ensure that the nylon blocks are correctly seated, in place on the cross beam and that the cross beam is positioned in the correct direction.

With some assistance, carefully insert the cross beam through the top of each column at the same time and slide it down to the bottom. Repeat the same for the other end.

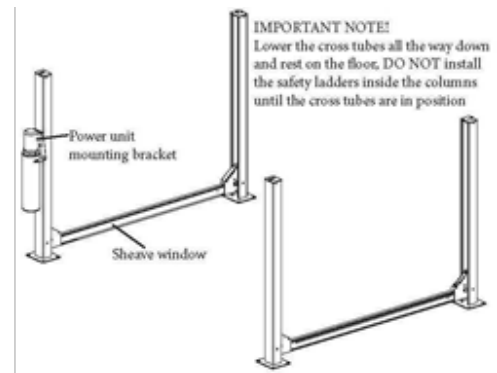

INSTALL THE SAFETY LADDERS

With the columns still laying on the floor, the cross beam in position (at the bottom of the column) install the safety ladders.

Start by threading a nut (Jam Nut) approximately halfway down the threaded end of the ladder. Install the ladder through the opening at the top of the column.

Make sure that the ladder drops down through the Slide Block guide slots on the cross beam and comes to rest (stops) on the column base plate.

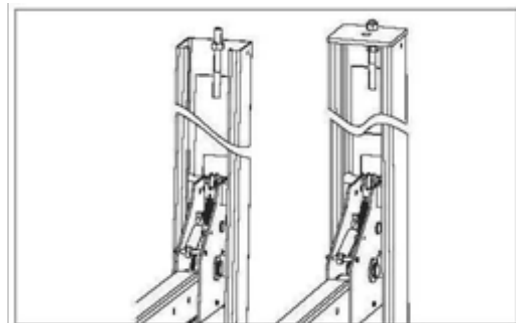
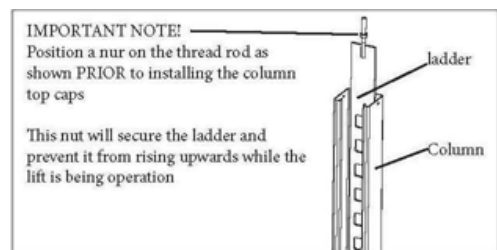

INSTALL THE COLUMN CAPS

Next install the column caps using the 2 x M16 nuts and washers. Ensure that the threaded rod on the top of the ladder has a nut (Jam Nut) then a flat washer on before placing the top cover above it.

Place the cover over the top of the column with the threaded pin from the top of the ladder inserted through the hole at the back with the cable hole closest to the inside.

With the assistance of another person or lifting device raise all columns and place in the marked-out locations.

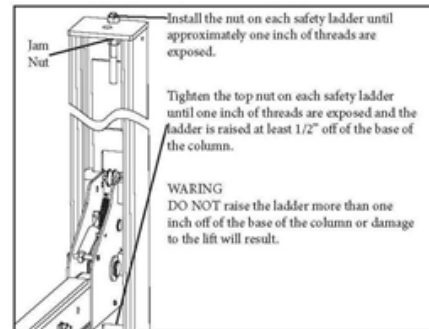
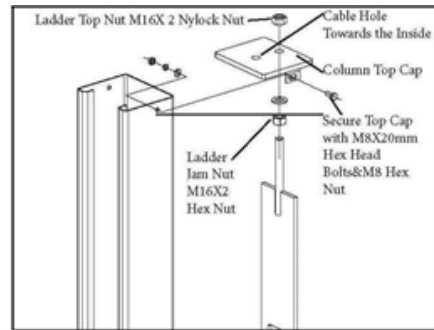

SETTING THE LADDER GAPS

IMPORTANT NOTE The ladder must be raised at least 12mm off the base of the column or damage to the lift will occur.

To see the base of the column the cross beam must be raised slightly. With the assistance of a friend raise the cross beam enough so a trolley jack can be placed below to support the weight.

Using the jack, raise the cross beam just enough to see the base of the column. Do not raise it to engage in any locks.

Slacken/release the nut below the cover and tighten up the top nut until the ladder has raised at least 12mm off the base of the column. (This may require a little adjustment)

When the 12mm gap has been set, tighten the bottom nut back up and the top nut down against the cover to stop the ladder from pulling itself out when the lift is raised.



SETTING THE PRIMARY SAFETY LOCKS

With the trolley jack still in place, raise the cross beams a little further until they engage into the first holes of the safety locks on the ladders.

At this stage, both the **primary safety locks** and the **slack safety locks** will be engaged in the ladder. However, this is not the intended way the safety locks should operate. The **slack safety lock** must not be engaged in the ladder. They are spring loaded and should only ever activate in the event of cable failure.

To correct this error and **set the slack safety lock**, raise the cross beam up using the trolley jack so the safety locks are 'sitting' between the first and second holes in the ladder.

With both locks retracted back and no longer locked into the ladder, press and hold each small cable pulley in toward the columns keeping them retracted, whilst simultaneously lowering the jack. This will allow only the primary safety lock to engage, and the slack safety lock will remain retracted as shown.

Once the cables are installed, they will provide the tension required to keep the slack safety lock retracted. Ensure the locks are correctly set on all four columns.

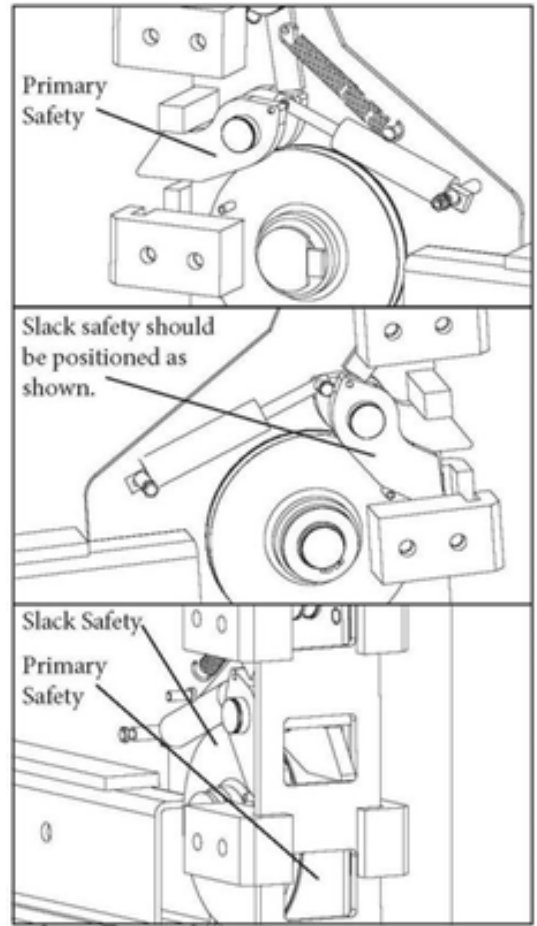

MOUNTING THE RUNWAYS ONTO THE CROSS BEAMS

There are two runways, Power-side and off-side. The Power-side runway contains the pre-installed hydraulic cylinder and safety cables. The offside runway does not.

The runways can be mounted in two [2] different locations depending on the size requirements of the vehicle to be lifted.

Narrow setting is **1922** wide.

Wide setting is **2080** wide.

CAUTION. The runways are heavy. Use an engine crane or lifting device to take the weight of the power-side runway when removing the steel transport frames from both ends. It is recommended that there is at least a person at both ends to support the runway and a third person to manage the engine crane.

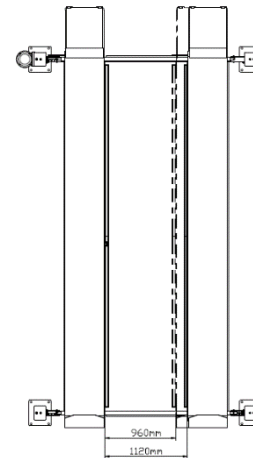

POWERSIDE INSTALLATION RUNWAY

The Powerside runway must be mounted on the side with the power unit column, with the utility rail facing inwards.

Remove any pre-installed Cable sheaves from the Powerside runway while paying attention to the order in which they are removed. (This will help at the time of re-installation. Take a picture if required for best reference)

Position the Powerside runway on top of the cross beam with the utility rail towards the center. The Flex Tube Holes located at the side should be adjacent to the power unit column. (front left-hand side column)

Align the holes in the runway with the holes on the cross beam and bolts together using four M12x1.75x90 Hex head bolts and washers, lubricate bolts with WD-40 or equivalent and torque to 55 ft/lbs

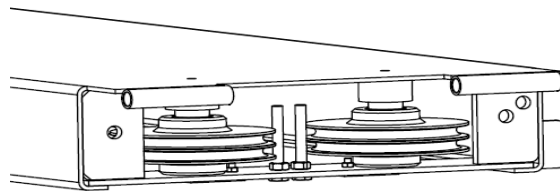
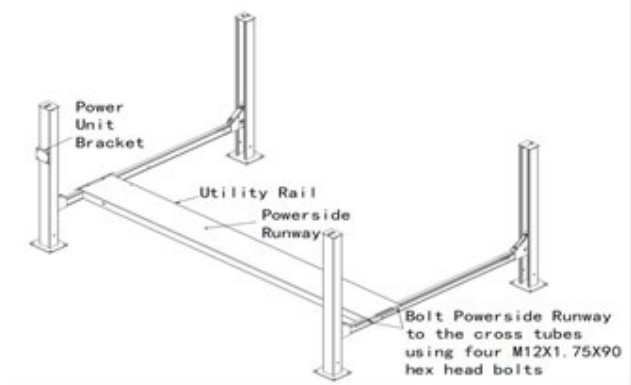

OFFSIDE RUNWAY INSTALLATION

Repeat the same lifting procedure to install the Offside runway, by placing the Offside Runway on top of the cross beam with the utility rail located inside.

Align the holes in the runway with the holes on the cross beam (at the chosen size) and bolt together using four M12x1.75x90 Hex head bolts and washers, lubricate bolts with WD-40 or equivalent and torque to 75Nm.

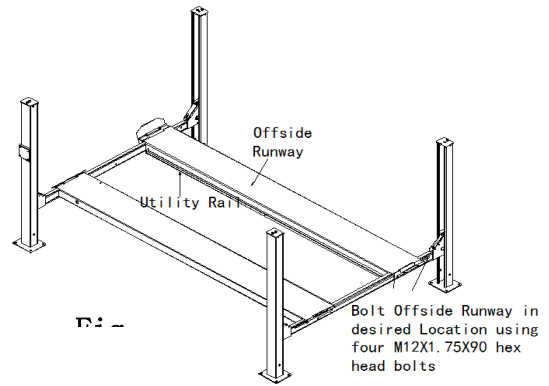

IMPORTANT NOTICE

DANGER:

DO NOT PROCEED with cable installation or enter the lift work area unless visual confirmation is made of **ALL Safety locks** being engaged.

ALL locks MUST be engaged before proceeding. Failure to comply with this instruction may result in severe personal injury or death.

CABLE & SHEAVE INSTALLATION

IMPORTANT NOTE –POWERUNIT LOCATED ON THE FRONT LEFT-HAND SIDE COLUMN

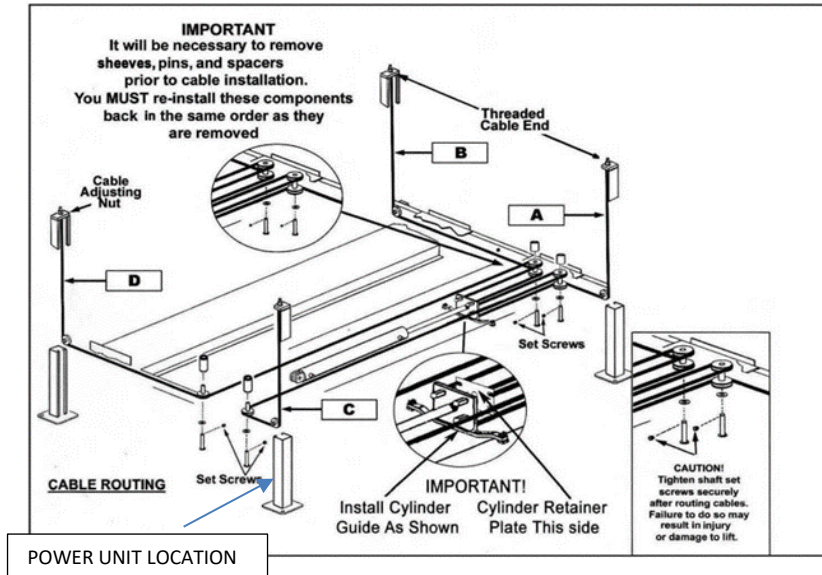

The above diagram displays the cable routing. With the runways roughly in position remove all sheaves, pins, rollers and spacers prior to the cable installation. (Be sure to note the position and order items are taken off as they will need to be replaced in the same way as they came off)

Care must be taken when routing the lifting cables to ensure they are routed below the cross beam mounting bolts. Lug ends of cables start at the cylinder end. Run the four cables from the powerside runway through the windows in each cross beam and out to the columns.

NOTE - The safety cables aren't long enough to reach beyond the ends of the cross beams. This is because the hydraulic cylinder stroke is not currently in sync with where the cross beams are sitting on the ladders.

To increase the cable length the hydraulic cylinder must be extended manually. To do this remove the red plastic bung from the other end of the hose (that goes to the power unit).

Pull the end of the cylinder out by sliding the nylon blocks along the underside of the runway. This will give more cable slack at each corner allowing the cables to be pulled up through the slack safety pulleys and out through top caps on each column.

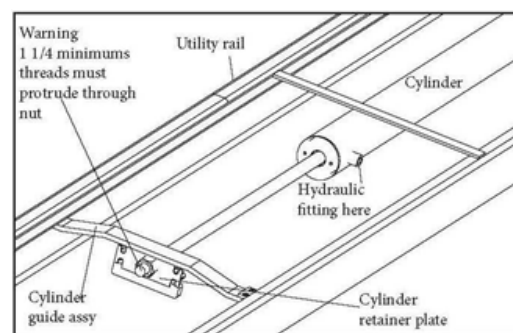
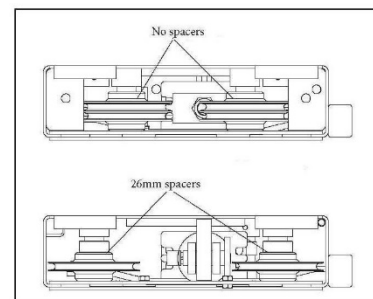

Now with more cable slack at each corner pull the cables up through the slack safety pulleys and out through top caps on each column.

Care must be taken when routing the lifting cables to ensure they are routed below the cross beam mounting bolts.

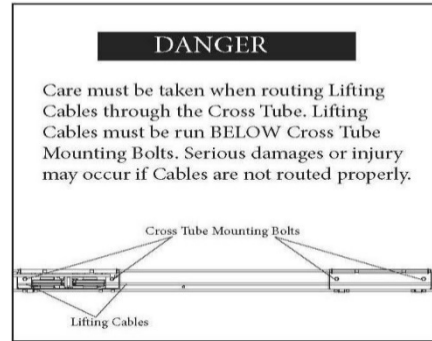

Next, route the cable over the **Slack Safety Sheaves** then to the top of each column.

Secure the cable using the M18 flat washer and hex nut. (See fig 6.3) removing some of the excess safety cable slack.

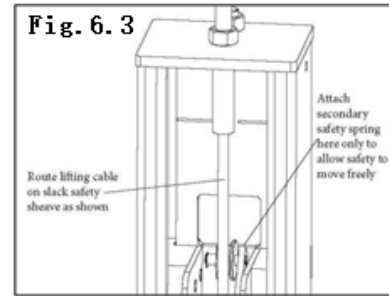

Tighten each nut until there are at least **25mm of threads protruding through the nut on the top cap of each column to eliminate any access cable slack.**

Proceed with caution when first operating the hoist to ensure that the cables remain in their pulleys.

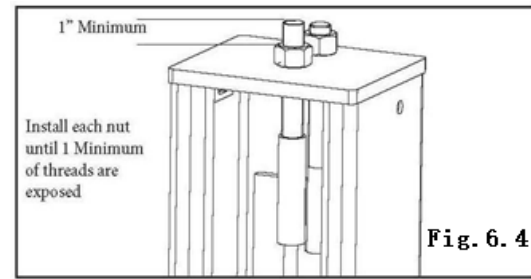

After routing the cables double-check to make sure all are properly positioned and remain within the grooves of all sheaves

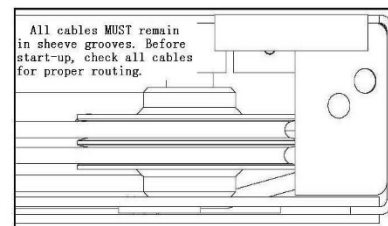
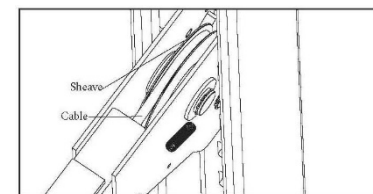

Fig. 6

POWER UNIT LOCATION

IMPORTANT NOTE

The Power Unit can be located at either of the “X” locations shown on the diagram.

It is **vital that the POWERSIDE Runway (with Cylinder)** is on the **SAME SIDE** closest to the power unit location.

Utility rails on the side of each **Runway MUST** be installed to the inside. As previously defined, we will illustrate the Power Unit mounted at the front left-hand side Column.

To locate the Power Unit on the rightside, rotate lift 180 degree leaving Approach Ramps and Front Tire Stops in original position.

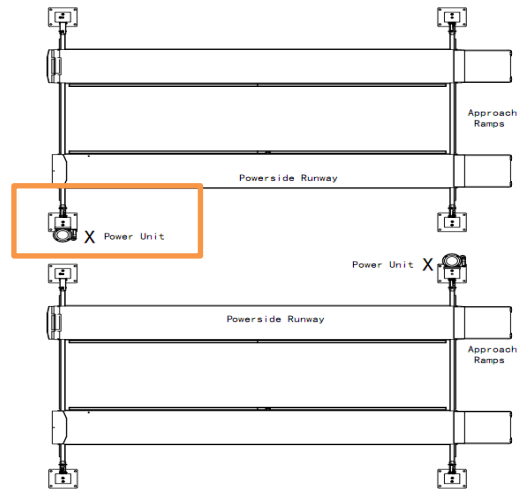

INSTALL THE POWER UNIT

Install the power unit on the Powerside column bracket mount using the four (4) x M8 x 20mm with M8 washers and M8 nylon lock nuts. Tighten the locking nuts so that the power unit does not move in any direction.

Two extra brackets also need to be attached, one for the hose protector and the other for the pneumatic switch.

Note. Power Unit fitting position.

The standard Power Unit for your lifts is 220 volt, 60HZ, single phase.

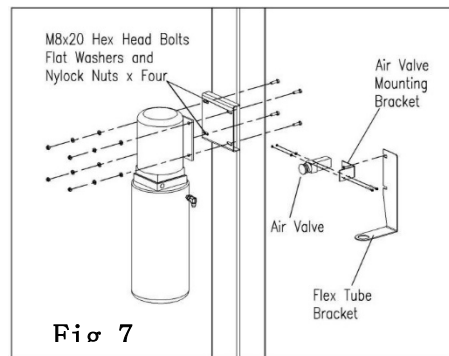

IMPORTANT POWER-UNIT INSTALLATION NOTES

- **NEVER** run power unit with no oil. Damage to the pump will occur.
- The power unit must always be kept dry.
- Damage to power unit caused by water or other liquids is not covered under warranty.
- Improper electrical hook-up can damage motor and will not be covered under warranty.
- Use a separate breaker for each power unit.
- Operate lift only between temperatures of 4° - 41°C.
- Protect each circuit with circuit breaker.
- For 220-240 volt, single phase, use a 20 amp fuse.
- For 380-440 volt, three phase, use a 15 amp fuse

INSTALL THE HYDRAULIC SYSTEM HOSES

With the power unit mounted, connect the hydraulic hose from the cylinder. The hoist hydraulic system runs a single hydraulic cylinder, which connects to the Power Unit.

Start by first rotating the tank of the power unit 90-degrees clockwise looking down from the motor end, install the 90-degree hydraulic fitting to the POWER PORT on the power unit.

Now run the hose through the tabs under the power-side runway and then out through the hole in the side. Attach the plastic protector before you connect the hydraulic hose to the 90° fitting on the power unit .

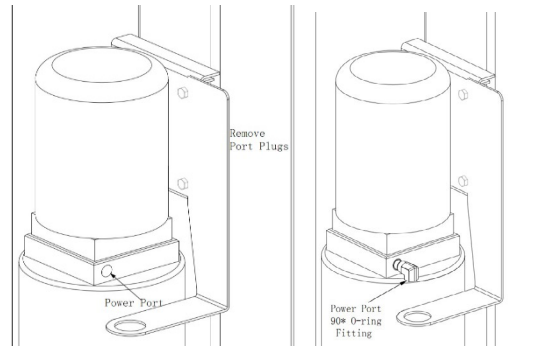

Now, fit one end of Flex Hose into hole in the Powerside runway adjacent to the power unit.

Fit the other end of the Flex Hose to the Flex Hose Bracket Assembly.

Tighten the Plastic Nut securely

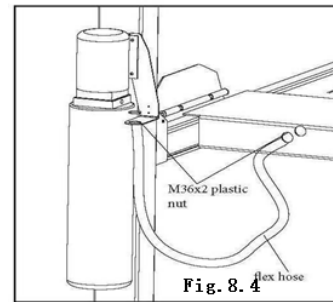

Connect the hoses as shown making sure to pass through the retaining rings.

MAKE SURE HOSES ARE KEPT CLEAR OF CABLES.

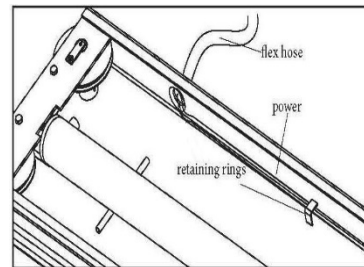

Pneumatic lock valve plumbing.

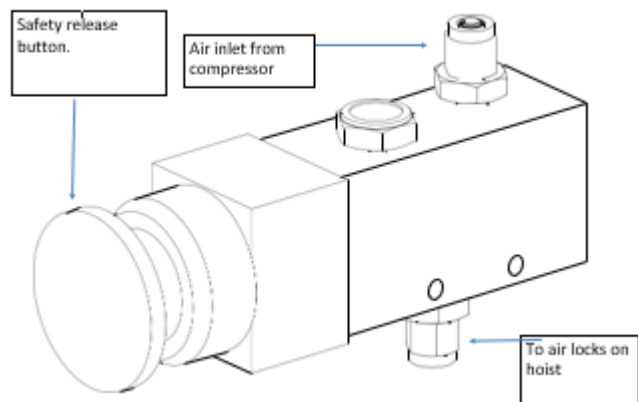

Next, run the power unit hydraulic hose, airline and breather line to the power unit.

The air hose and breather hose also need to run through this same hole. See further in installation document for air hose install.

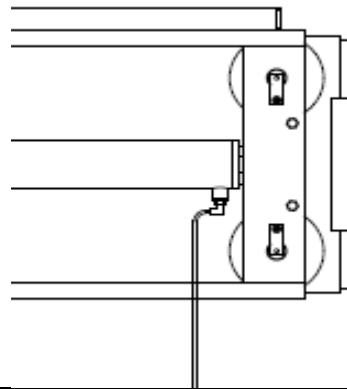
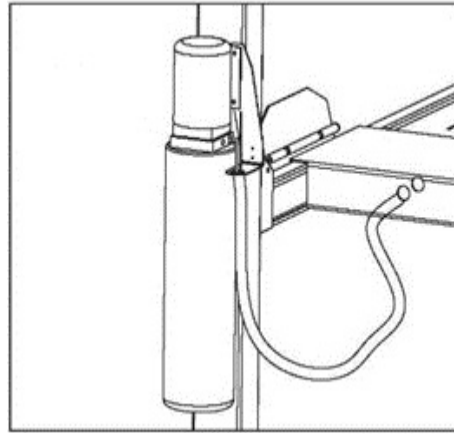

Connect the Power Unit Hydraulic Line to the 90-degree Power Unit Fitting.

Connect the hydraulic ram breather line to the power unit. This is the small blue line coming from the base of the hydraulic ram.

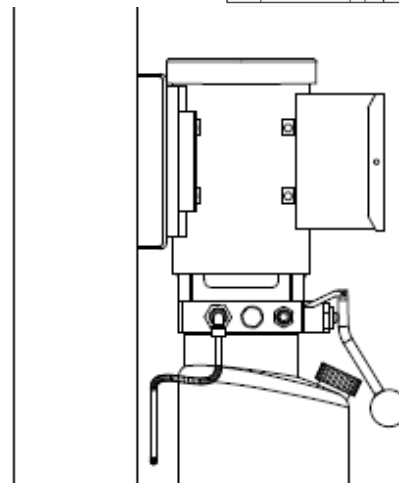

FILLING THE POWER UNIT WITH HYDRAULIC OIL

Double check all the fittings are tight before adding any hydraulic oil.

Fill the tank with ISO 46 hydraulic oil by removing the dipstick and filling the tank with roughly **12 litres of hydraulic oil** or till it becomes visible towards the top of the dipstick.

Note that you may need to top it up once you have run the hoist up and down a few times to bleed the air from the system.

NOTE Hydraulic oil must be changed after the first week of operation and then every 12 months or as needed depending on frequency of use.

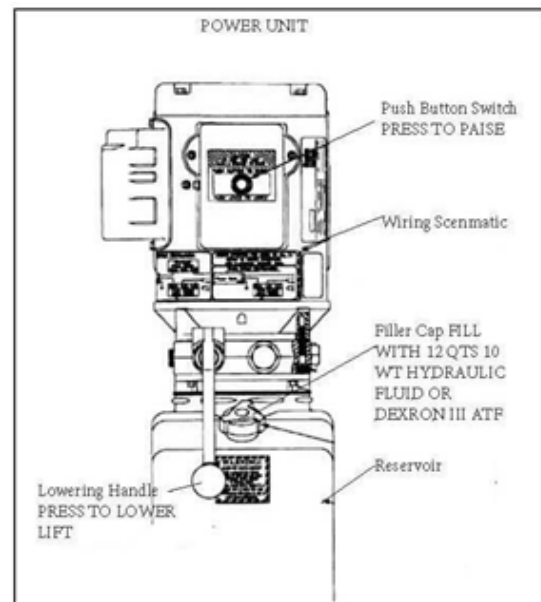

CONNECTING THE AIR SOURCE TO THE SAFETY ACTUATORS

Start by attaching the pneumatic switch to the bracket provided. It is recommended to replace the bottom push fitting with a 1/4" BSP Nitto style fitting to allow the air compressor to directly connect to the hoist.

Make sure to position the push button air valve with the **INLET** facing towards the **AIR SOURCE** and the **OUTLET** facing the direction of the LIFT.

Cut the Provided 6mm airline tubing with a sharp blade to lengths as required. Tubing must be cut square with no burrs.

Run the first airline around the power unit bracket and in alongside the hydraulic hose so it can enter the power-side runway.

In the powerside runway, connect the airline to a tee fitting that splits (Male Branch "Tee" fitting) the air line between each end of the hoist. Attach hose both sides of the Tee so it comes out of the extra hole in the cross beam on both ends of the hoist and goes directly into another tee fitting that splits it between the left and right columns.

Run the air hose across the cross beam on both sides, which is the safety lock release actuators situated at each individual column. When completed you can press all four caps on to the cross beams to protect the safety lock release actuators.

A filter/regulator/lubricator must be installed on the air supply line at the lift. Failure to do so will void the warranty.

Note: To assemble airline tubing into fitting, use firm, manual pressure to push tubing into the fitting until it bottoms out.

Pay careful attention to keep air line clear of any pinch points. Improper assembly may result in safety lock failure.

AIR PRESSURE SHOULD BE REGULATED TO 125 PSI MAX.

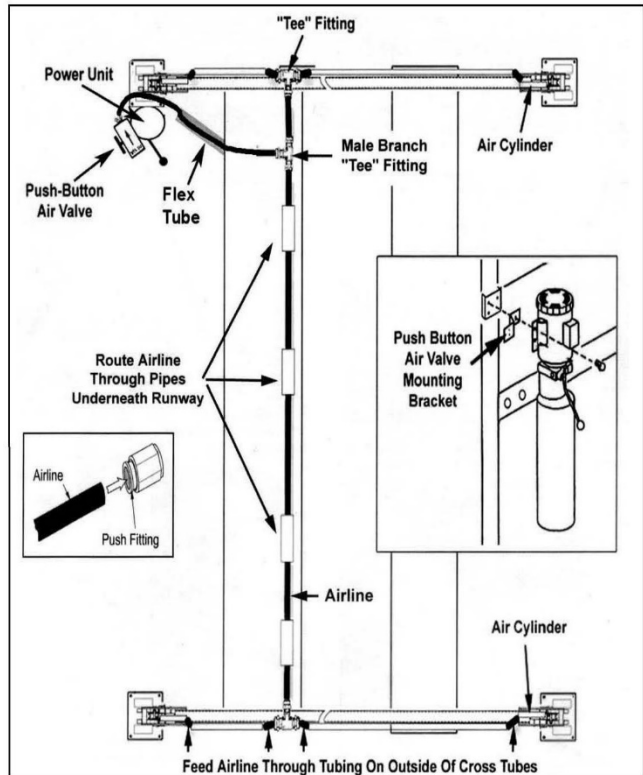

CONNECT ELECTRICAL TO THE POWER UNIT;

CAUTION

This equipment has internal arcing or parts that may spark and should never be exposed to flammable vapors. The motor should not be placed or installed in a recessed area or below floor level.

With the air hose connections tightened and checked, the pneumatic locks are now able to be released. However, to do so we first need to raise the hoist slightly and for that it will need power.

Please note that you will need a certified electrician to wire up the 16AMP power unit for you. It is illegal to carry out this step yourself and we do not recommend that you do so.

 **WARNING:** A certified electrician must install all electrical wiring. Each circuit should have protection with a time delay fuse or circuit breaker. A commercial licensed electrician is recommended to understand the circuitry of the hoist and complete the electrical works.

Minimum requirements required include,

- A 20Amp dedicated circuit with a D curve Breaker.
- An isolator switch mounted close to the hoist location.



WARNING:

Lock Out (disconnect) electrical supply before installing any electrical components or performing maintenance on the lift. Do not ever allow power supply to be connected when working on or repairing lift.

INSPECTING THE SLACK SAFETY SPRINGS

The following steps involve **CONFIRMING THE SLACK CABLE SAFETY DEVICE** and **MAIN SAFETY** are correctly set.

Failure to follow these steps could result in serious injury or death in the event of cable failure.

Inspect the ends of the **SLACK SAFETY LOCK SPRINGS** as shown.

Make sure the spring ends are secure at both ends.

DO NOT ATTEMPT TO RAISE THE LIFT UNTIL THE SLACK SAFETY SPRING ARE ATTACHED AND THE ROLLERS ARE PULLED CLEAR FROM THE LADDER

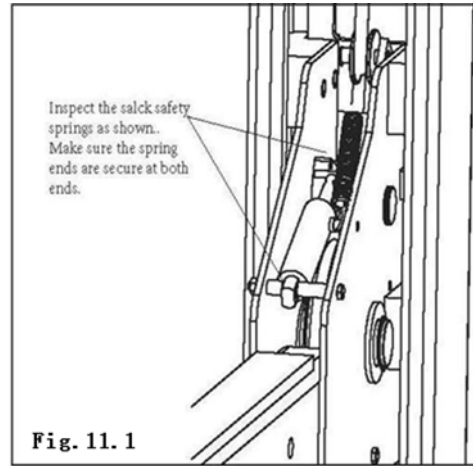

Inspect the slack safety springs as shown. Make sure the spring ends are secure at both ends.

Fig. 11.1

LEVELING THE RUNWAYS & ADJUSTING SAFETY CABLES

With the hoist still secured on the first safety locks, it is now time to level the runways.

Confirm that the concrete floor is level by using a tape measure to ensure that the four ends of the runways are at the same height. If they aren't, simply adjust the ladder heights until they match, making sure that the ladders don't end up resting on the bottom of the columns. (This should be minor adjustments only).

To lower the ladder, undo the top nut slowly till the desired height has been reached, then tighten up the lower nut (Jam nut) until it sits firmly against the top plate. If the ladder needs to rise, simply do this procedure in reverse.

If the floor is not level use a laser level across the runways or a very long spirit level instead. Once you have your runways sitting level with the hoist on the locks, raise the hoist a few centimeters further until the safety cables take the weight.

Now measure all four corners again and then adjust the cables this time to level out the runways. This should now have all four locks clicking in sync as you raise the hoist up.

BLEEDING THE AIR FROM THE HYDRAULIC SYSTEM

To begin the bleeding process, at the power unit make sure that the **emergency stop** is out. Power up the hoist until it reaches the maximum travel permitted.

Next release the safety locks by pressing the pneumatic switch, then using the lever, let the runways lower all the way back down.

This can be a slow process with no weight on the runways. The hoist operation will be jerky to begin with, this is due to air escaping from the lines. Repeat the process of cycling the hoist up and down two or three times until a smooth operation is achieved, which means the air has been bled correctly. Note, the safety locks should click at the same time going up if you have adjusted your cables correctly. If they are still slightly out of sync make some final adjustments to the cables until they align with each other.

INSTALLING THE RAMPS & WHEEL STOPS

Position the ramps on the end that you would like to use as the entry point.

To attach the ramp, slide the pin/s through the guides on the cross beams and through the ramps to attach them.

Insert a split pin on each end to keep them secured in place.

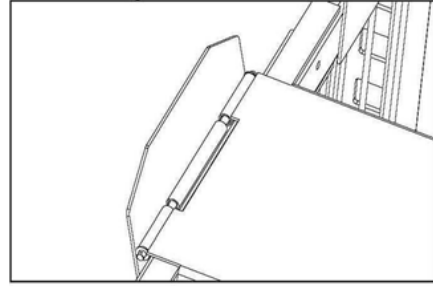

Repeat the same for the wheel stops on the other end, with the flat edge facing the top.

Any extras purchased for your 4 Post Hoist such as the [Optional Jacking Plate](#) or [Plastic Drip Trays](#) now is a good time to install them.

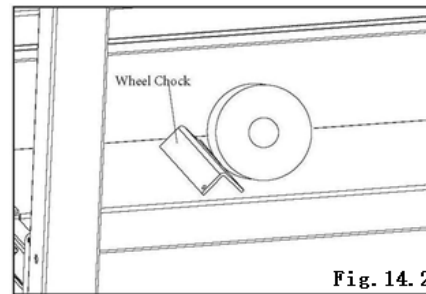

FINAL ADJUSTMENTS & LIFT START UP

Make sure the Power Unit reservoir is full, containing at least 12L of 32 or 46 grade hydraulic oil.

Before proceeding, double-check to make sure all cables are properly positioned within the grooves of **ALL Sheaves**. Make sure all cable Sheave retaining Pins and/or Clips are secure. Check to make sure that all **Slack Safety Locks** are clear and free from obstruction.

Now, test the Power Unit by pressing the push-button switch. Begin to raise the lift slowly, checking all the hydraulic hose connections for leaks. If the motor gets hot or sounds strained or peculiar, stop and check all electrical connections.

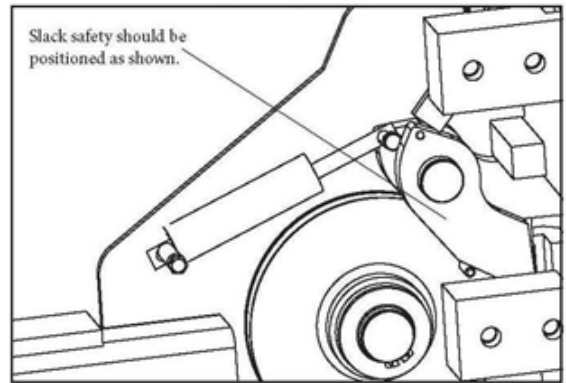

Continue to raise the hoist until the cables get taught and the lift starts to rise.

RAISE LIFT UNTIL THE CYLINDER REACHES ITS LIMIT (BOTTOMS OUT) AND THE LIFT STOPS. ADJUST EACH CABLE SO THAT EACH SAFETY LOCK RESTS AT ONE INCH ABOVE THE TOP SAFETY LOCK POSITION.

It may be necessary to tighten or loosen each cable to reach the proper height. The cable nuts **MUST** be tightened until there is at least **25mm** of thread protruding above the nut. With the air supply connected, press the **PUSH BUTTON AIR VALVE** and check that **all Safety Locks are functioning properly**. Lower the lift by pressing the push button air valve and power unit lowering valve simultaneously.

Do a final check on all **MAIN SAFETY LOCKS** to make sure they move freely and spring back to the lock position when released. Lubricate all SAFETY PIVOT points with WD-40 or equal.

Finally, run the lift up and down a few times to ensure that the Locks are engaging uniformly and that the safety release mechanisms are functioning. Re-adjust if necessary.

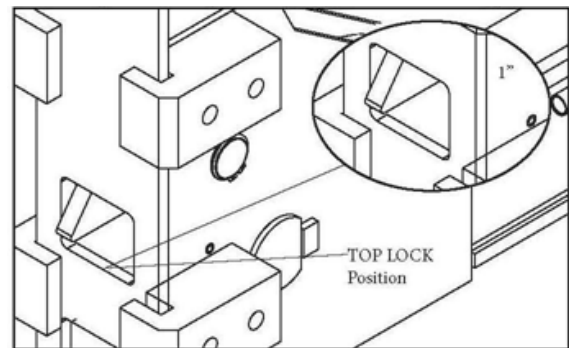

WARNING

NOTE: There will be initial stretching of the cables in the beginning and/or with increased loads. It is **vital for hoist safety** that the cables as outlined above are adjusted a week after first use, then every three to six months thereafter depending on usage and/or to compensate for stretching. **KEEP HANDS AND FEET CLEAR AT ALL TIMES!** Remove hands and feet from any moving part and any pinch points. Keep feet away when lowering lift.

ANCHORING THE COLUMNS

The Hoist is now completely assembled and unlikely to move so it is time to secure the columns to the concrete.

Before drilling any holes, double check the measurements and position of all columns are correct and that the bases of each column are square and aligned with the layout lines.

Begin by drilling the four 16mm holes to the correct depth (120mm) on each column and then use compressed air to clear out the concrete dust before driving in your anchors with a large hammer.

Once completed, tighten all the anchor bolts down until they are firmly secured.

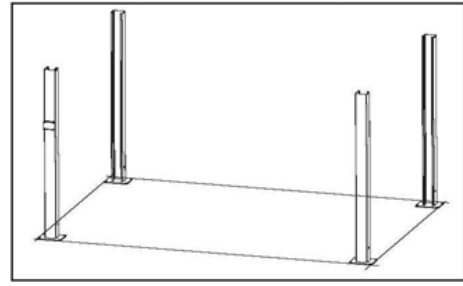

Using the Base plate on each column as a guide, drill each anchor hole approximately 120mm deep using a rotary hammer drill and 16mm concrete bit

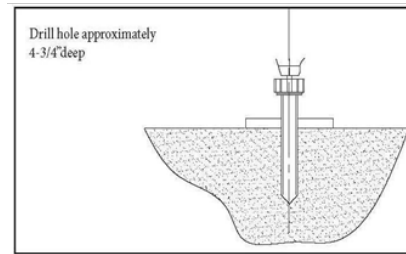

After drilling, remove the dust thoroughly from each hole using compressed air. Make certain that the columns remain aligned with the layout lines.

Assemble the washers and nuts on the anchors then tap each hole with a hammer until the washer rests against base plate. Be sure that if shimming is required, enough threads are left exposed.

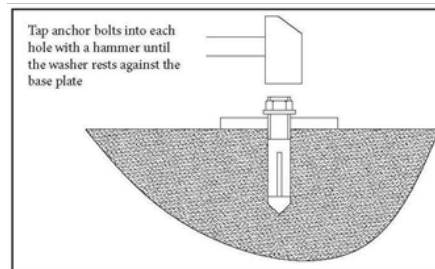

If shimming is required, insert the shims as necessary to the base plate so when the anchor bolts are tightened, the columns will be plumb.

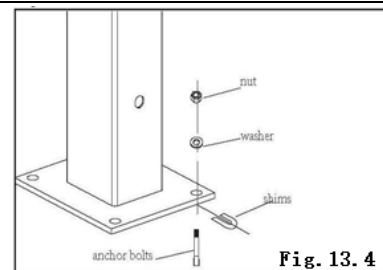
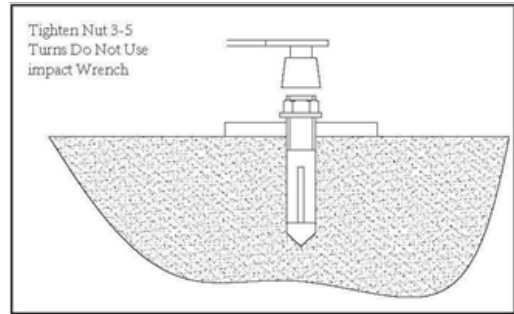

Fig. 13.4

Following shims installation tighten each nut 3-5 turns past hand tight.

IMPORTANT-if anchor bolts do not hold when torque to required amount the concrete is sub-standard for this specific purpose and **must be** replaced.

Saw cut and remove a 1m x 1m square area below the effected column base then re-pour with reinforced SL62 mesh and 32Mpa concrete to a depth of 125mm minimum, keying new concrete under existing floor.



DRILLING NOTES FOR EXPANSION ANCHORS.

CAUTION: Anchors must be at least 200mm from the any edge of the slab or any seam.

- Use only the recommended bit size (16mm) and type - masonry.
- Keep the drill in a perpendicular line while drilling.
- Let the drill do the work. Do not apply excessive pressure. Lift the drill up and down occasionally to remove residue to reduce binding.
- After drilling blow the dust from the hole.

INSTALLING EXPANSION ANCHORS AND LEVELING THE COLUMNS

- Using a spirit level, check the columns are plumb. If the column is not plumb, using the horseshoe shims provided, shim the column base as required until each column is plumb. If one column must be elevated to match the plane of the other column, add shim plates. Shim thickness **MUST NOT** exceed 5mm when using the 120mm long anchors provided with the lift.
- Once the columns are both straight and in position, complete the installation of the remaining anchor bolts by drilling the remaining holes on the sub floor base. Use the subbase anchor points as a template for drilling the holes.
- When installing the expansion anchors, like previously instructed, place a flat washer and hex nut over the threaded end of 16mm x 120mm anchor, leaving approximately 2mm of thread exposed carefully tap anchor (use a hammer and a block of wood). Do not damage threads. Tap anchor into the concrete until nut and flat washer are against base plate.
- Tighten the nuts on each bolt two or three turns. Check each anchor bolt with a torque wrench set to 100-foot pounds' torque. Re tighten the expansion anchors several hours after the initial installation. The anchors should be checked weekly to make sure they are properly affixed.
- **ATTENTION:** Mechanical anchors require a specific installation torque: Failure to apply the recommended installation torque can result in excessive displacement of the anchor under load or premature failure of the anchor. These anchors will lose pre-tension after setting due to pre-load relaxation.
- If anchors **do not tighten to 135Nm**. installation torque, replace the concrete under each column base with a **1m x 1m x 125mm thick 32MPa minimum concrete pad** keyed under and flush with the top of existing floor. Allow concrete to cure before installing lifts and anchors (typically 28 days).

POST INSTALLATION PROCEDURE:

✓ Check boxes to verify work has been completed.

	Verify columns are properly shimmed and plumb
	Check that expansion anchors are tightened to 135Nm torque
	Roll pins / sheave pins / hardware / fasteners properly attached and torqued
	Wire ropes in pulley grooves
	Electrically wired by a professional technician
	Equalizing cables and safety latches in synchronization
	Safety latches functioning properly
	Check for "no" hydraulic leaks
	Oil level full
	All components functioning properly
	All integral moving parts lubricated
	Check for overhead obstructions
	All hardware secure (nuts, bolts, pins)
	Working area clean
	Operation, maintenance and safety manuals in designated location



OPERATION MANUAL

JGG-4PSTSTD

STANDARD 4000KG

4 POST CLEAR FLOOR HOIST

OPERATOR TRAINING AND SAFE PRACTICES.

Keep a copy of these instructions close by and stored in a protected dry location readily available for operators. Each operator must read and carefully follow all safety instructions. Ensure all operators understand how to operate the product safely and correctly before use. Failure to operate this product as intended may cause injury or death.

Prior to each use, on a regular basis, carefully inspect the product and perform all maintenance as required. Service and maintain the product only with authorized or approved replacement parts; negligence will make the product unsafe for use and may void the warranty.

Keep and maintain that all decals on the product remain clean and visible. Do not modify and/or use this product for any application other than that for which this product was designed. If you have any questions related to a particular application contrary to the product's specific functions, **DO NOT** use the product until you have first contacted **Joel's Garage Gear** to determine if it can be performed using the product.

GENERAL SAFETY RULES



WARNING: Read and understand all instructions. Failure to follow all instructions listed below may result in serious injury or death.



WARNING: The warnings, cautions, and instructions discussed in this instruction manual cannot cover all possible conditions or situations that could occur. It is understood and agreed by the operator that common sense and caution are factors that cannot be built into this product. It is the operator's responsibility to adhere to the instructions and operating procedures described in this manual to successfully operate this product.

IMPORTANT SAFETY CONSIDERATIONS

To maintain the product and user safety, you must: -.

- Always check for damaged or worn-out parts before using the hoist. Broken parts will affect the equipment operation. Replace or repair damaged or worn parts immediately.
- Not modify the product in any way. Unauthorized modification may impair the function and/or safety and could affect the life of the equipment.
- Keep instructions readily available for equipment operators.
- Make certain all operators understand how to operate the unit safely and correctly.
- Allow unit operation only with all parts in place and operating properly.
- Use only genuine replacement parts.
- Service and maintain the unit only with authorized or approved replacement parts; negligence will make the product unsafe for use and void the warranty.
- Carefully inspect the unit on a regular basis and perform all maintenance as required.
- Keep all decals on the unit clean and visible.

HAZARD DESCRIPTIONS

Identify the hazard levels used in this manual with the following definitions and signal words:

 **DANGER:**

Immediate hazards which will result in severe liability or exposure to personal injury or death.

 **WARNING:**

Hazards or unsafe practices which could result in severe personal injury or death.

 **CAUTION:**

Hazards or unsafe practices which may result in personal injury, product or property damage

SAFETY MARKINGS

Pay close attention and follow all the safety markings.

- Do not exceed rated capacity.
- Do not move or dolly the vehicle while on the hoist.
- No alterations shall be made to this product.
- Only attachments and/or adapters supplied by the manufacturer shall be used.
- Do not get under or allow anyone under the vehicle until it has been supported with an auxiliary jack stands on both the front and rear of the vehicle.
- Center load on lifting arms and saddles prior to lifting.
- Secure vehicle to ensure no shifting, movement, or tipping will occur when performing maintenance on any vehicle.
- Verify that safety locks are engaged before performing any work.
- Do not use this product for any use other than the manufacturer specified usage. Failure to heed these warnings may result in personal injury and/or property damage.



WARNING:

DO NOT USE wooden blocks or any other non-approved load sustaining devices or any other non-approved lifting devices for a means of lifting a vehicle or load being raised. The manufacturer only warrants loads to be sustained by adapters or accessories validated by the manufacturer. Failure to heed these warnings may cause injury or death.



GENERAL OPERATOR SAFETY INSTRUCTIONS:

TRAINING

Do not allow anyone who has not read this operating manual, and/or does not understand the requirements to use the product.

BYSTANDERS

Keep all bystanders away from hoist when in use. Do not allow bystanders under the load supported. Do not allow anyone within a vehicle while the hoist is in use or is supporting a load.

OPERATORS

Not for use by children or people with reduced mental capacity. Do not use under the influence of any drugs or alcohol.

INSPECTION

Inspect the product carefully before each use. Ensure the product is not damaged, excessively worn, or missing parts. Do not use the hoist unless it is properly lubricated. Using a hoist that is not in good clean working condition or properly lubricated may cause serious injury.

INTENDED USE

This four-post car hoist is designed to lift and raise light duty vehicles up to 4000kgs.

GENERAL OPERATION

USE THE HOIST CORRECTLY AND IN A PROPER MANNER. Never use lifting adapters other than what has been supplied by the manufacturer.

- Positioning the vehicle is very important. Only people trained in operating the hoist should position the vehicle on the hoist. Never allow anyone to stand in the path of the vehicle as it is being positioned.
- Some vehicle maintenance and repair activities may cause the vehicle to shift. Follow the manufacturer's guidelines when performing these operations.
- The use of jack stands, or alternate lifting points may be required when completing some repairs for additional security. Special care must be used when lifting light duty trucks.
- Always use these lifting points – (see lifting point guidelines). Running boards and other installed accessories may also require optional adapters.
- Ensure vehicle is balanced, failure to do so can cause injury and/or death.
- Removal or installation of heavier parts can change the vehicle's center of gravity on the hoist resulting in a critical load shift. The vehicle may then be unstable. Plan for this possibility to ensure continued safety and **always** refer to the vehicle manufacturers' service manual for recommended procedures.
- Do not allow customers/friends/children or unauthorized personnel to operate the hoist or remain in the surrounding area during use.
- **DO NOT** remove any heavy component from vehicle that may cause excessive weight shift.
- **ALWAYS** keep the hoist area free of obstructions and debris.
- **NEVER** raise a vehicle with passengers inside.
- Before **lowering a vehicle**, check the hoist and surrounding area and remove all obstructions.

- **ALWAYS** Make sure the vehicle's center of gravity is always safe before raising the vehicle. All points of contact on vehicles should always be double checked. Always make sure the vehicle is secure before lifting using vehicle manufacturers' recommended lifting points.
- Large vehicles, such as limousines, RVs, and long wheelbase vehicles, may not be suitable for lifting on this equipment. Check with the vehicle manufacturer.
- **DO NOT** rock or shake the vehicle while working on or around the hoist.
- **VERIFY** that all safety latches are engaged and lowered on to the safety latch ladders before any attempt is made to work on or near vehicle.
- **NEVER** override self-operating hoist controls.
- **NEVER** remove any safety related components, parts or safety stickers from the hoist. Do not use the hoist if any safety related component or part is damaged or missing.
- **DO NOT** block open or override self-closing hoist controls; they are designed to return to the "Off" or Neutral position when released.
- **DO NOT** remove or disable arm restraints.
- **DO NOT** hit or run over the hoist arms or adapters. This could damage the hoist or vehicle. Before driving the vehicle into hoist bay, position arms and adapters to provide unobstructed entrance onto the hoist.
- **USE THE HOIST ONLY AS DESCRIBED IN THIS MANUAL.**
- Use only manufacturer's recommended attachments.
- The troubleshooting and maintenance procedures described in this manual can be done by the hoist's owner. Any other procedure should only be performed by trained hoist service personnel. These restricted procedures include, but are not limited to, the following: **cylinder replacement, safety latch replacement, or electrical troubleshooting/repair.**
- **PAY ATTENTION** when walking under a vehicle that is raised on the vehicle hoist.



DANGERS:

- To reduce the risk of personal injury, keep hair, loose clothing, fingers, and all body parts away from moving parts.
- This equipment has internal arcing or sparking parts. To reduce the risk of electric shock the motor and hoist should not be exposed to moisture or water.
- To reduce the risk of fire, do not operate equipment in the proximity of open containers containing flammable liquids (example: Gasoline, flammable solvents).
- Anyone who will be in the vicinity of the hoist when it is in use should familiarize themselves with all the **Caution, Warning, and Safety** related decals supplied with this hoist and replace them if they are illegible or missing.

SAFETY STICKER IDENTIFICATION

Below are the Safety Sticker identifications and markings that are on the hoist. These identifications are put in place to help with your safety and the safety of others. Always use caution when working around the vehicle hoist.

Please maintain these Safety Marking so safe operating practices can be maintained by each operator.

**IMPORTANT
OPERATION / MAINTENANCE
INSTRUCTIONS FOR 4-POST
AUTOMOBILE LIFT PLEASE READ**

OPERATION

- Adjust ramp width as necessary so that vehicle tires are in center of each ramp.
- Set parking brake or use a wheel chock to hold vehicle in position.
- Before raising vehicle, be sure all personnel are clear of the lift. Pay careful attention to the overhead so as not to raise the vehicle into an obstruction.
- Raise vehicle to the desired working height.
- Lower lift on nearest safety ladder to support load.
- Do not permit the chains to go slack.

TO LOWER THE LIFT

- First, raise the lift to clear the safety ladder.
- Depress air safety release button and HOLD.
(If not so equipped, manually raise the 4 safety catches.)
- Pull the lowering handle and hold until the lift has descended completely.
- If the lift is shaking, vibrating or swaying, reduce the descending speed. Consult your manual or call the factory.
(Lift should descend at the same speed as raising.)

WEEKLY MAINTENANCE

- Lubricate chains with SAE 30 oil.
- Check all chain connections, bolts, and pins to insure proper mounting.
- Lubricate primary safety pivot pin with general purpose lubricating oil.
- Lubricate the 4 air cylinders by placing approximately 2 drops of general purpose oil down the piston shaft hole.
- Lubricate all rollers with 90 wt. gear oil or equivalent.

MONTHLY MAINTENANCE

- Check safeties making sure they are in good operating condition.
- Inspect all anchor bolts and retighten if necessary.
- Check post for straightness according to manufacturers specifications.
- For lift with ramp options: Follow procedure as outlined above for normal lubrication of pivot points and safety inspection.

WARNING

1. **WARNING:** If cement anchor bolts are loose, or any component of the lift is found to be defective, DO NOT USE LIFT!
2. Never operate the lift with any person or equipment below.
3. Always stand clear of lift when lowering or raising.
4. Never exceed the rated capacity.
5. Always insure safeties are engaged before any attempt is made to work on or near vehicle.
6. Never leave lift in an elevated position unless the safeties are engaged.

**ALL ROLLERS MUST BE
LUBRICATED WEEKLY WITH
90 WT. GEAR OIL OR EQUIVALENT.
COVER MOTOR IF OUTSIDE DAMAGE TO
MOTOR CAUSED BY DAMP CONDITIONS IS
NOT COVERED UNDER WARRANTY.**

DANGER

SAFETY LOCKS
ENGAGED
OK TO PROCEED

SAFETY LOCKS
NOT ENGAGED
REMAIN CLEAR

VISUALLY CONFIRM
THAT ALL PRIMARY SAFETY
LOCKS ARE ENGAGED BEFORE
ENTERING WORK AREA.

Suspension components used on this lift are intended to raise and lower lift only and are not meant to be load holding devices. Remain clear of elevated lift unless visual confirmation is made that all primary safety locks are fully engaged and the lift is LOWERED onto the safety locks. Refer to installation/operation manual for proper safety lock procedures and/or further instruction.

<p>⚠ CAUTION</p>  <p>Lift to be used by trained operator ONLY.</p>	<p>⚠ CAUTION</p>  <p>Authorized personnel only in lift area.</p>	<p>⚠ WARNING</p>  <p>Chock wheel to prevent vehicle movement.</p>	<p>⚠ WARNING</p>  <p>Do not override self-closing lift controls.</p>
<p>⚠ WARNING</p>  <p>Remain clear of lift when raising or lowering vehicle.</p>	<p>⚠ WARNING</p>  <p>Clear area if vehicle is in danger of falling.</p>	<p>SAFETY INSTRUCTIONS</p>  <p>Read operating and safety manuals before using lift.</p>	<p>SAFETY INSTRUCTIONS</p>  <p>Proper maintenance and inspection is necessary for safe operation.</p>
<p>⚠ WARNING</p>  <p>Keep feet clear of lift while lowering.</p>	<p>⚠ WARNING</p>  <p>Keep clear of pinch points when lift is moving.</p>	<p>SAFETY INSTRUCTIONS</p>  <p>Do not operate a damaged lift.</p>	<p>The messages and pictographs shown are generic in nature and are meant to generally represent hazards common to all automotive lifts regardless of specific style.</p> <p>Replacement labels sets may be obtained from the original lift manufacturer.</p>

WARNING

WIRE ROPE INSPECTION AND MAINTENANCE

- Lifting cables should be replaced every three years or when visible signs of damage are apparent. **DO NOT USE LIFT WITH DEFECTIVE/WORN CABLES.**
- Wire rope should be maintained in a well-lubricated condition at all times. Wire rope is only fully protected when each wire strand is lubricated both internal and external. Excessive wear will shorten the life of the wire rope. The factory suggested wire rope lubricant that penetrates to the core of the rope and provides long-term lubrication between each individual strand is AMSOIL Synthetic Open Gear and Wire Rope Compound. In order to make sure that the inner layers of the rope remain well lubricated, lubrication should be carried out at intervals not exceeding three months during operation.
- All sheaves and guide rollers in contact with the moving rope should be given regular visual checks for surface wear and lubricated to make sure that they run freely. This operation should be carried out at appropriate intervals generally not exceeding three months during operation. For all sheave axles, the factory recommends standard wheel bearing grease. For all sheaves and/or guide rollers, the factory recommends 90-WT gear oil or similar heavy lubricant applied by any method including pump/spray dispensing, brush, hand and/or swabbing.

**Failure to read, understand, and follow these instructions may cause death or serious injury.
Read and understand these instructions before using lift.**

HOW TO OPERATE THE HOIST

- **ONLY AUTHORIZED PERSONNEL** should operate the hoist.
- Make sure all operators have been trained and have reviewed the **OPERATOR AND SAFE PRACTICES** of this manual before using the hoist.
- Familiarize yourself with the **Safety Precautions** to be followed when operating this hoist.
- Always allow a minimum 2-second delay between motor starts. Failure to comply may cause the switch and/or motor to burn out. This could cause serious damage to the equipment and/or personal property.
- Use only recommended **ISO AW32 or AW46** hydraulic oils. Oil must be changed after the first week of operation and once every 12 months or as needed. Add extra oil as needed.
- Have a complete understanding of the carriage safety lock mechanisms.
 - The **“LOCKED position”** will be used when raising the hoist. This function should always work automatically.
 - The **“UN-LOCKED position”** will be used when lowering the hoist to the ground.
- **Note: DO NOT** remove or tamper with the design of the locking assembly.

- *Failure to use locks as designed or forcing a lock to stay in the open position during use will be grounds for immediate termination of any warranty.*
- **ALWAYS** ensure the safety is engaged before any attempt is made to work under, on or near the vehicle.
- **NEVER** leave the hoist in elevated position unless the safeties are engaged.
- **NEVER** operate the hoist (up or down) with any person or equipment below the vehicle.
- **NEVER** exceed the rated lifting capacity.
- **DO NOT ALLOW THE ELECTRIC MOTOR TO GET WET!** Motor damage caused by dampness is not covered under warranty.
- After positioning the vehicle, set the emergency brake (Hand Brake), make sure the ignition is off, the doors are closed, and overhead obstructions are cleared.
- Make sure the vehicle is not front or rear heavy. The center of balance should be in the middle of the columns.

 **DANGER:**

DO NOT RAISE OR LOWER ANY VEHICLE UNLESS TOOLS, MATERIALS AND PEOPLE ARE CLEAR.

CLEAN UP GREASE AND OIL SPILLS IMMEDIATELY. When the hoist is being lowered, make sure everyone is standing at least six feet away. Always lower the vehicle down when the area is safe and clear.

DESCRIPTION OF LIFT CONTROLS

Description:	Purpose:
Safety Release Button (air valve)	Used to release safety latches when lowering vehicle.
Power "ON" Button	Controls electrical power to the hydraulic power unit. Push to turn-on.
Lowering Handle	Used to relieve hydraulic pressure when pressed to lower lifting carriages.
Fill Cap	Power unit fill Cap for the power unit fluid reservoir. Remove to add fluid.
Tank	Used to store hydraulic fluid.

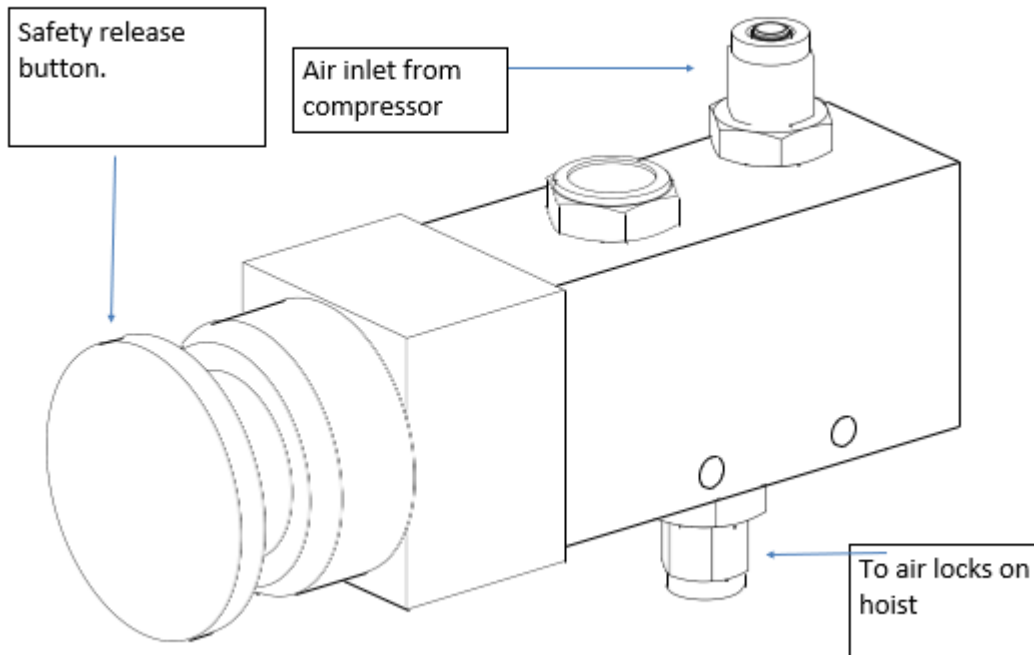
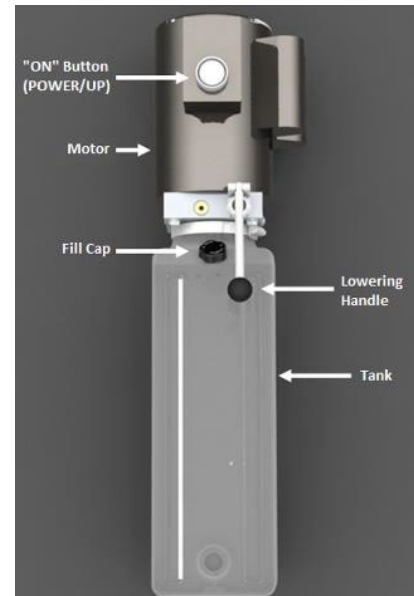

LOADING A VEHICLE ON THE HOIST

PRIOR TO LIFTING: The hoist must be fully lowered, and the service bay clean of all personnel and equipment before the vehicle is brought on the lift.

LOADING: With the hoist runways at the lowest position drive the car slowly onto the runway ramps continuing along the runway till the wheel stops engage. Do not travel over 5KM per hour.

Once the vehicle is securely parked, it is safe to lift, raise the vehicle to the desired height, keeping in mind any height restrictions. As the vehicle raises the safety locks will click as the hoist rises.

When the desired height is reached make sure the lever is used to lower the hoist down onto the primary safety locks before working under it!

When it's time to lower the hoist, the hoists primary safety locks will still engaged, and you will not be able to lower it without first raising it slightly (30mm). To lower your vehicle, first press the button to raise the hoist off the safety locks a few centimetres. Then press and hold the pneumatic switch whilst at the same time pushing the lever down.

RAISING THE HOIST WITH VEHICLE LOAD,

- Prior to raising any vehicle, ensure the vehicle's is positioned evenly along the platforms.
- Press the power "on" button.
- As the hoist rises a clicking sound will be heard. These are the carriage ladder locks that securely hold a vehicle.
- Once the desired height has been achieved slightly raise the carriage a little more, so the runways are just above the last latch position, (confirmed by the clicking sound) then slowly lower the load on the safety locks.
- **NEVER** attempt to raise or 'creep' the hoist by continually pressing the 'on' button in short bursts. This will cause critical damage to the hydraulic system, that could cause hydraulic failure.
- Verify that both Safety Carriage locks have been engaged before beginning work.

LOWERING THE HOIST WITH VEHICLE LOAD

- Prior to lowering the hoist
 - Always remove tool trays, stands and any other equipment that may cause obstruction.
 - Always release safety locks before attempting to lower the hoist.
- To lower the hoist, first raise the hoist to clear the safety latches, press the power "on" button, then the pneumatic lock release valve button. The locks should now be UN-LOCKED.
- Simultaneously hold the Safety Locks in the UN-LOCKED Position and press the lowering control valve on the power unit.
- Lower the hoist slowly until reach the lowest retracted position and the platform ramps are on the ground.

WHEN LOWERING THE LIFT PAY CAREFUL ATENTION THAT ALL PERSONNEL AND OBJECTS ARE KEPT CLEAR.

ALWAYS KEEP A VISUAL LINE OF SITE ON THE LIFT AT ALL TIMES. ALWAYS MAKE SURE THAT ALL LOCKS ARE DISENGAGED. IF ONE OF THE LOCKS INADVERTENTLY LOCKS ON DESCENT THE LIFT AND/OR VEHICLE MAY DISRUPT CAUSING PERSONAL INJURY OR DEATH

WEEKLY MAINTENANCE INSPECTION RECORD

DATE: _

Mark OK for all Items in good working order.

	Lubricate posts with grease. Lubricate the four inside corners of the columns with heavy-duty bearing grease as needed.
	Check that all posts are square and plumb.
	Check equalizer cable tension, and adjust if necessary, see manual instructions. Lubricate Cable Sheaves.
	Check all cable connections, bolts, and pins to ensure proper mounting and torque.
	Check safety latch synchronization: Safety latches should click at the same time. If necessary, adjust equalizing cables as described in the Installation Instruction section of this manual.
	Check the tightness of all bolts and hardware. Re-tighten as needed. See installation manual torque specific ratings.
	Inspect all anchor bolts and retighten if necessary. Re-torque as needed. See the installation manual for instructions.
	Make a visual inspection of all moving parts and check for excessive signs of wear.
	With the hoist in the lowered position, check the hydraulic fluid level. If needed, add oil as described in the Installation Instruction section of this manual.
	Check all warning labels and power unit safety stickers are in good condition. Replace all caution, warning or safety related decals on the lift if unable to read or missing. Reorder labels from manufacturer.

DANGER: If anchor bolts are loose or any component of the lift is found to be defective, **DO NOT USE THE LIFT.**

- **ALWAYS** keep lift components clean.
- **ALWAYS** if oil leakage is observed, place lift out of service and contact Customer Service.
- **ALWAYS** contact a local service representative if electrical problems develop.
- **ALWAYS** keep bolts tight.
- **ALWAYS** replace ALL FAULTY PARTS before lift is put back into operation.
- Refer to ANSI/ALI ALOIM booklet for periodic inspection checklist and maintenance log sheet.



NOTES: _____

PRINT COPY PAGES FOR DAILY RECORDS

WIRE ROPE INSPECTION MAINTENANCE



Know when to replace your cables! The pictures below will help you assess when you will need to replace wire rope. For Additional Information see "Wire Rope User's Manual 4th Ed."

All wire rope, sheaves and guide rollers in continuous service should be observed during normal operation and visually as per the scheduled maintenance. A complete and thorough inspection of all ropes in use must be made as below and all rope which has been idle for a period of a month or more should be given a thorough inspection before it is put back into service. Factors such as abrasion, wear, fatigue, corrosion, improper winding and kinking are often of greater significance in determining if a wire rope is usable. Use the pictures as shown as guide for determining when to replace your wire rope.

Recommended Lubrication Product:

A high grade penetrating lubricant for wire rope, chain and cable that contain a petroleum solvent that carry the lubricant into the core of the wire rope, then evaporates, leaving behind a heavy lubricating film to protect and lubricate each strand. A penetrating lubricant is essential in any lubrication program as most wire rope fails from the inside out.

Check all guide rollers, sheaves and hardware that are in operational contact are visually checked for wear and lubrication

HOW TO INSPECT WIRE ROPE?

- I. Relax the rope to a stationary position and move the pick-up points off the sheaves. Clean the surface of the rope with a cloth this will allow you to see breaks. (Use a stiff wire brush, if necessary.)
- II. Flex the rope to expose any broken wires hidden in the channels between the strands.
- III. Visually check for any broken wires. One way to check for crown breaks is to run a cloth along the rope to check for possible snags.
- IV. With an awl tool, probe between wires and strands and lift any wires that appear loose. Evidence of internal broken wires may require a more extensive rope examination. **(IF IN DOUBT REPLACE CABLES)**
- V. Check for layer to layer crushing or individual wires that may have been displaced from their normal position.
- VI. Check Sheaves for deeply corrugated sheaves that may also be causing damage to wire ropes. Replace sheaves if needed.

- VII. Replace wire rope if any failing condition is found.
 - ✓ Equalizing and Lifting Cables should be replaced every three years when visible signs of damage are apparent. **DO NOT USE THE HOIST WITH DAMAGED OR WORN CABLES.**
 - ✓ A lubricant suited to the conditions under which the rope is operating should then be applied. Several methods are suggested, and the one most suited to the installation and lubricant being used may be chosen. It is better to lubricate lightly and frequently than heavily and infrequently. For best results lubricate to core of cables.
 - ✓ **Improve rope performance and overall effectiveness**
 - ✓ **Check all guide rollers, sheaves and hardware that are in operational contact are visually checked for wear and lubrication.**
 - ✓ **Visually Inspect and Apply lubricants to all contact points using a heavy weight lubricant using the methods as described: spray, pump, brush or hand lubrication.**

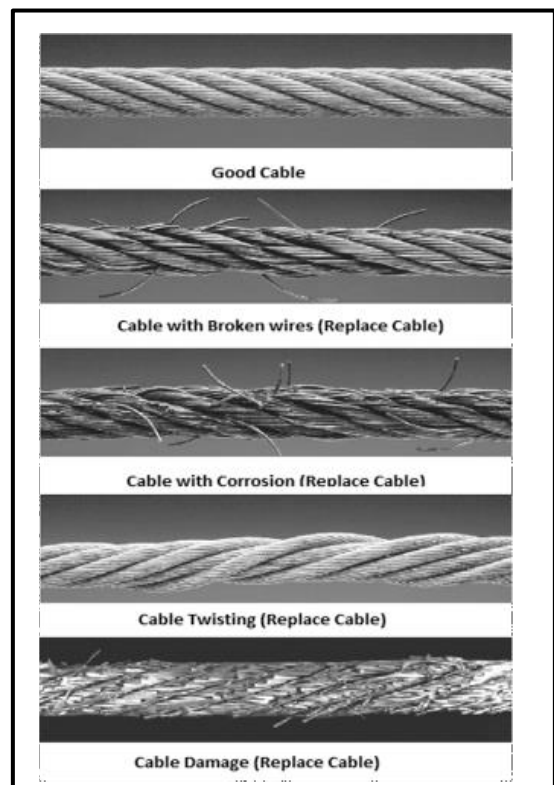

TROUBLESHOOTING

HOIST WILL NOT RAISE

Air is in the oil	<ul style="list-style-type: none"> • Check for proper oil level. The oil level should be up to the dip stick in the reservoir with the hoist all the way down. • Bleed cylinders. See Installation Manual • Oil seal damaged or cocked. Replace oil seal around pump shaft. • Inlet screen clogged. Clean inlet screen or replace
Cylinder is binding	<ul style="list-style-type: none"> • Contact Customer Service.
Cylinder leaks internally	<ul style="list-style-type: none"> • Contact Customer Service
Hoist does not raise and lower smoothly	<ul style="list-style-type: none"> • Reposition vehicle for a more even weight distribution. • Check the four inside corners of the four columns for roughness. Any rust or burrs must be removed with emery cloth. • Lubricate the four corners with heavy duty bearing grease. • Use a level to check the columns for vertical alignment both side to side and front to back. Shim the columns as necessary per the Installation Instruction section of this manual. • Check the oil level. • Inspect that there is no air in the hydraulic lines. Bleed the hydraulic system as described in the Installation Instruction section of this manual.
Lowering valve is leaking	<ul style="list-style-type: none"> • Contact Customer Service
Motor runs backwards	<ul style="list-style-type: none"> • Check if the motor is wired correctly. Compare wiring of motor to electrical diagram on drawing. • Check wall outlet voltage and wiring. Make sure the unit and wall outlet are wired properly. • Contact Customer Service
Motor run backward under pressure	<ul style="list-style-type: none"> • Contact Customer Service
Power Unit will not stop running	<ul style="list-style-type: none"> • The switch is damaged. Turn off power to the hoist and replace switch
Pump is damaged	<ul style="list-style-type: none"> • Contact Customer Service
Pump will not prime	<ul style="list-style-type: none"> • Check for proper oil level. The oil level should be up to the dip stick in the reservoir with the hoist all the way down. • Flush release valve in case it is jammed open. Hold release handle down and start unit allowing possible contamination to be flushed out, run for 15 seconds. • Oil seal damaged or cocked. Replace oil seal around pump shaft. • Replace with new part. • Check pump-mounting bolts. Bolts should be 20Nm. • Inlet screen clogged. Clean inlet screen or replace. • Check wall outlet voltages and wiring. Make sure the unit and wall outlet are wired properly. • Contact Customer Service
Relief valve leaks	<ul style="list-style-type: none"> • Contact Customer Service
Voltage to the motor is incorrect	<ul style="list-style-type: none"> • Check if the motor is wired correctly. Compare wiring of motor to electrical diagram on drawing. • Check wall outlet voltages and wiring. Make sure the unit and wall outlet are wired properly. • Contact Customer Service.
The power unit does not run	<ul style="list-style-type: none"> • Check electrical supply breaker or fuse. • Check micro-switch and connections in motor control box. • Check voltage to the motor.
The power unit runs but does not raise the hoist	<ul style="list-style-type: none"> • Check the oil level. • Check that the lowering valve is not stuck open. • Check the connections and components on the suction side of the pump.
The power unit raises the hoist empty but will not lift a vehicle	<ul style="list-style-type: none"> • Make sure the vehicle is not above the rated capacity of the hoist. • Make sure the vehicle is positioned properly. • Clean the lowering valve by running the power unit for 15 seconds while holding the lowering valve open. • Check the motor voltage.

TROUBLESHOOTING

MOTOR WILL NOT RUN

	Fuse is blown	<ul style="list-style-type: none"> • Check for correct voltage. Compare supply voltage with voltage on motor name tag. Check that the wire is sized correctly. Requires 2.5mm² for 20 Amps. • Check the motor is wired correctly. Compare wiring of motor to electrical diagram on drawing. • Don't use extension cords. The size of the conductors should be such that the voltage drop would not exceed 3% to the farthest outlet for power. • Reset circuit breaker/fuse. Reset circuit breaker/fuse. • Contact Customer Service.
	Switch is burnt out	<ul style="list-style-type: none"> • Check for correct voltage. Compare supply voltage with voltage on motor name tag. Check that the wire is sized correctly. Requires 2.5mm² for 20 Amps. • Check the motor is wired correctly. Compare wiring of motor to electrical diagram on drawing. • Don't use extension cords. The size of the conductors should be such that the voltage drop would not exceed 3% to the farthest outlet for power. • Contact Customer Service.
	Motor is burnt out	<ul style="list-style-type: none"> • Check for correct voltage. Compare supply voltage with voltage on motor name tag. Check that the wire is sized correctly. Requires 2.5mm² for 20 Amps. • Check the motor is wired correctly. Compare wiring of motor to electrical diagram on drawing. • Don't use extension cords. The size of the conductors should be such that the voltage drop would not exceed 3% to the farthest outlet for power. • Replace with a new part. • Contact Customer Service
	Voltage to the motor is not correct	<ul style="list-style-type: none"> • Check for correct voltage. Compare supply voltage with voltage on motor name tag. Check that the wire is sized correctly. Requires 2.5mm² for 20 Amps. • Check motor is wired correctly. Compare wiring of motor to electrical diagram on drawing. • Check wall outlet voltage and wiring. Make sure unit and wall outlet is wired properly. Motor must run at 220-240 VAC.

 **DANGER:**

IF A VEHICLE BECOMES STUCK ON THE HOIST IN THE AIR, FOLLOW ALL OPERATION INSTRUCTIONS AS SHOWN IN THE OPERATING INSTRUCTIONS AND TROUBLESHOOTING SECTION OF THIS MANUAL. IF AFTER OBSERVING THAT ALL MECHANICAL LOCKS ARE RELEASED AND THE HOIST STILL FAILS TO MOVE FOLLOWING ALL STANDARD OPERATING PROCEDURES, IMMEDIATELY STOP USING THE HOIST AND CONTACT CUSTOMER SERVICE FOR FURTHER INSTRUCTIONS.

GENERAL ASSEMBLY DIAGRAM

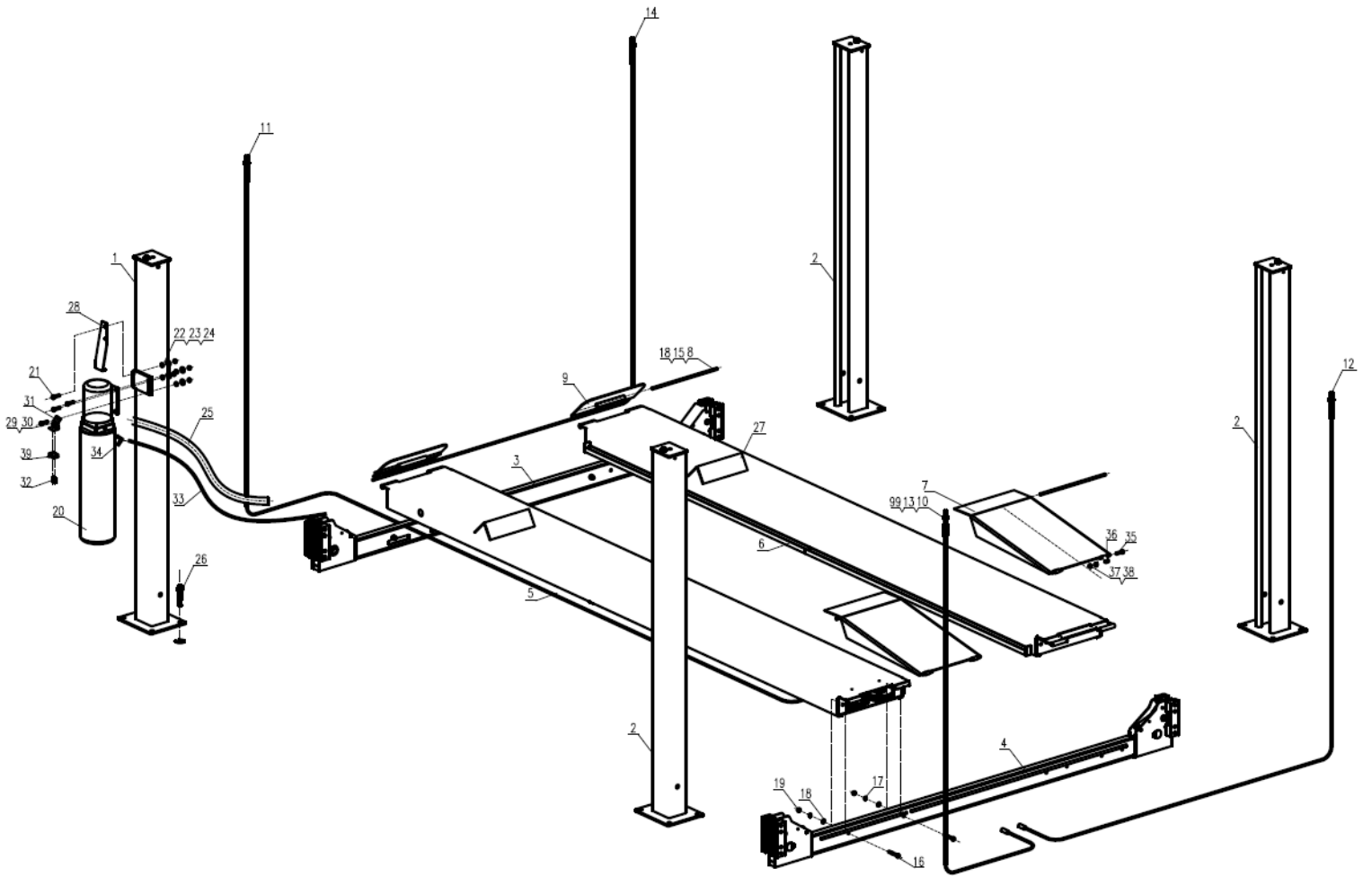

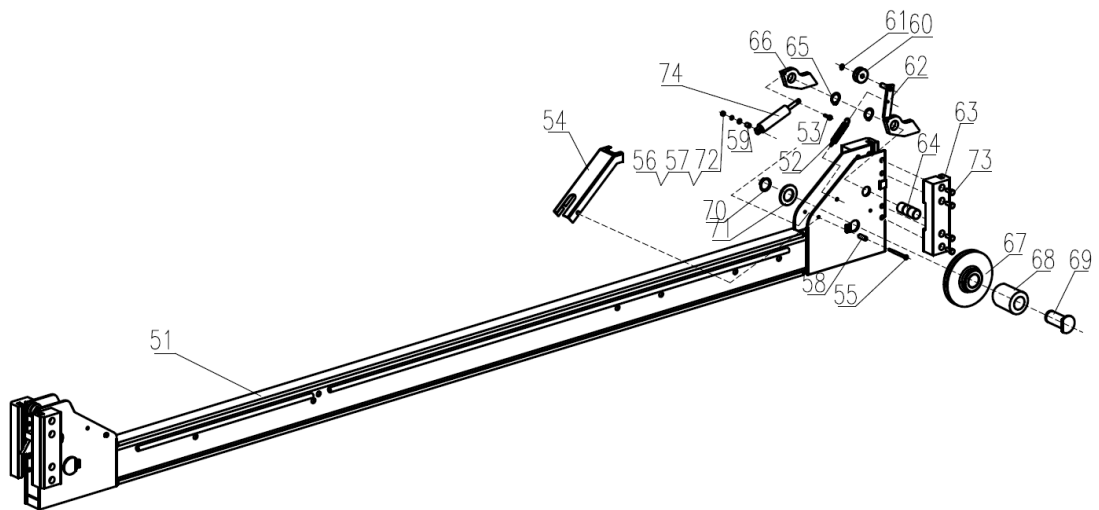
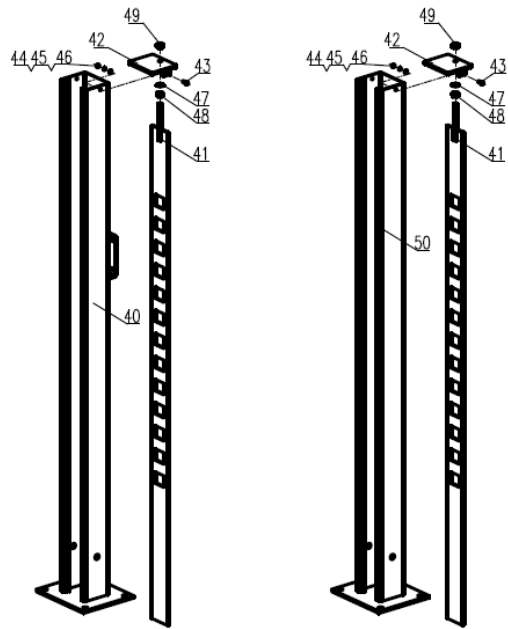

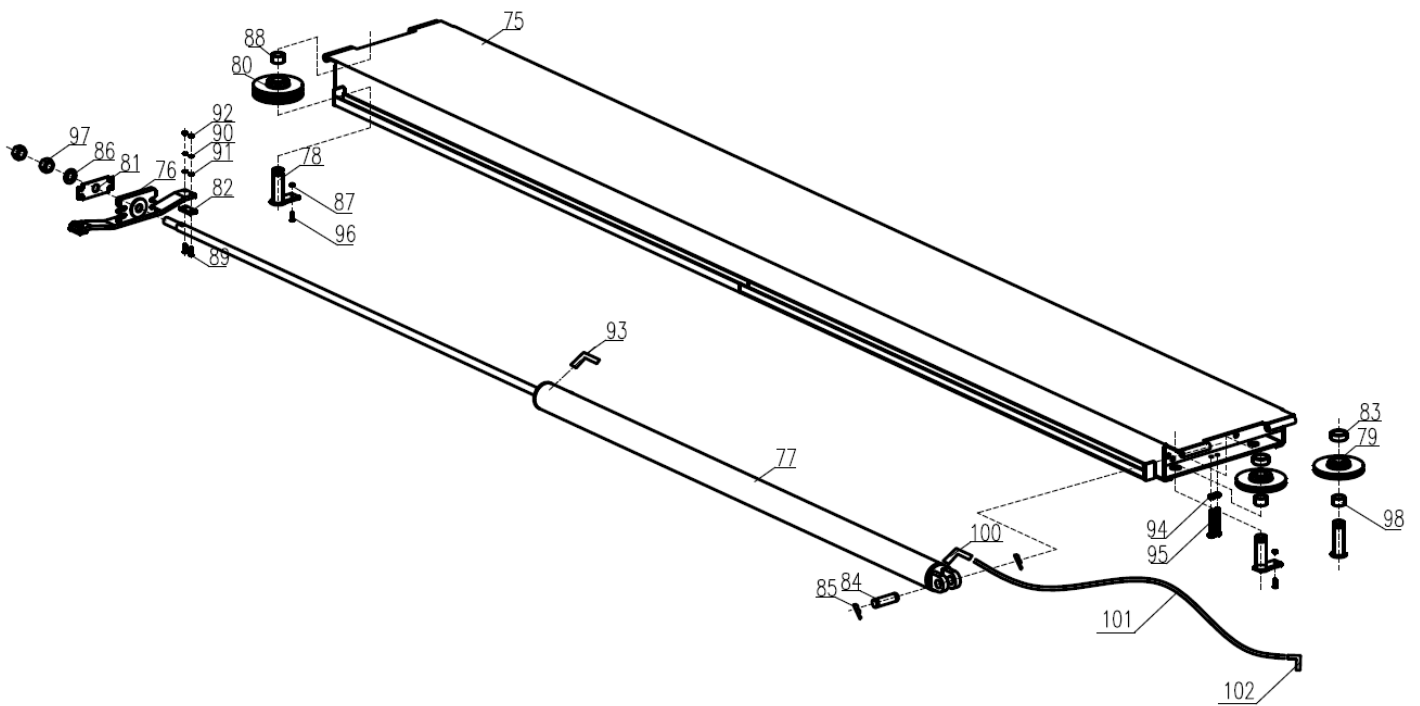

NO.	PART NO.	DESCRIPTION	QTY
1	QJY4030.1	MAIN-COLUMN ASSEMBLY	1
2	QJY4030.2	SECONDARY-COLUMN ASSEMBLY	3
3	QJY4040.3a	BEAM ASSEMBLY 1	1
4	QJY4040.4a	BEAM ASSEMBLY 2	1
5	QJY4040.5a	POWERSIDE RUNWAY	1
6	QJY4040.6	OFFSIDE RUNWAY	1
7	QJY4040.7.1	EXTENSION PART	2
8	QJY245DS.9-06	COTTER PIN	8
9	QJY4040.9	THE FRONT PART	2
10	GB889.1	NUT M18	4
11	QJY4040-01	CABLE1	1
12	QJY4040-02	CABLE2	1
13	QJY4040-03	CABLE3	1
14	QJY4040-04	CABLE4	1
15	QJY4040-05	LONG PIN	4
16	GB5782	BOLT M12X80	8
17	GB93	SPRING WASHER12	19
18	GB97.1	FLAT WASHER12	27
19	GB6170	NUT M12	19
20		POWER UNIT	1
21	GB5781	BOLT M8X22	5
22	GB93	SPRING WASHER8	5

23	GB97.1	FLAT WASHER 8	5
24	GB6170	NUT M8	5
25	QJY4040-17	SHEATH	1
26	QRKZ01-1999	EXPANSION SCREWS M16X140	16
27	QJY4040-09	STOP PLATE	2
28	QJY4040-06	SHEATH FIXING PLATE	1
29	GB6170	NUT M4	2
30	GB97.1	FLAT WASHER 4	2
31	QJY4040-08A	FIXING PLATE	1
32	GB818	BOLT M4X35	2
33	QJY4040.5-07	TUBING	1
34	QJY4040.5-01	PUMP STATION JOINT	1
35	GB5780	BOLT M6X80	4
36	QJY4040.7-04	ROLLER	4
37	GB6170	NUT M6	4
38	GB93	SPRING WASHER 6	4
39		VALVE	1
40	QJY4040.1.1	MAIN-COLUMN PART	1
41	QJY4040.1.2	INSURANCE POLICY COMPONENTS	4
42	QJY4040.1.3	COVER COMPONENTS	4
43	GB5783	BOLT M8X22	8
44	GB97.1	FLAT WASHER 8	8
45	GB93	SPRING WASHER 8	8
46	GB6170	NUT M8	8
47	GB97.1	FLAT WASHER 16	4
48	GB6170	NUT M16	4
49	GB889.1	NUT M16	4
50	QJY4040.2.1	SECONDARY-COLUMN ASSEMBLY	3
51	QJY4040.3a.1/QJY4040.4a.1	BEAM PART1/ BEAM PART2	1/1
52	QJY4040.3-01	SPRING	1
53	GB819	BOLT M6X25	2
54	QJY4040.3-09	BEAM COVER PLATE	2
55	GB5782	BOLT M6X70	2
56	GB97.1	FLAT WASHER6	2
57	GB93	SPRING WASHER6	2
58	QJY4040.3-02	LONG SPACER SLEEVE	2
59	QJY4040.3-03	SHORT SPACER SLEEVE	2
60	TLT440E-20-02	SAFETY ROLLER	2
61	GB894	RING10	2
62	QJY4040.3.2	INSURANCE COMPONENTS	2
63	QJY4040.3-05a	SLIDER	4
64	QJY4040.3-07	INSURANCE PIN	2
65	GB894	RING26	8
66	QJY4040.3-08	INSURANCE	2
67	QJY4040.3.4	STEEL CABLE PULLEY1	2
68	SF-2	BUSH3248	2
69	QJY4040.3.3	AXLE PART	2
70	GB894	RING32	2

71	GB95	FLAT WASHER30	2
72	GB6170	NUT M6	2
73	GB70.1	BOLT M10X30	8
74		AIR CYLINDER	2
75	QJY4040.5.1	MAIN BEAM COMPONENTS	1
76	QJY4040.5.2	CONNECTING BLOCK COMPONENTS	1
77	QJY4040.5.3	CYLINDER COMPONENTS	1
78	QJY4040.5.4	STEEL WHEEL AXLE COMPONENTS	4
79	QJY4040.3.4	CABLE PULLEY COMPONENTS1	2
80	QJY4040.5.5	CABLE PULLEY COMPONENTS2	2
81	QJY4040.5-02	CABLE FIXING PLATE	1
82	QJY4040.5-03	SLIDER	2
83	QJY4040.5-04	SPACER SLEEVE	2
84	QJY4040.5-05	CYLINDER FIXING PLATE	1
85	QJY245DS.9-06	LATCH	2
86	GB95	FLAT WASHER24	1
87	GB889	NUT M6	4
88	SF-2	BUSH 3266	2
89	GB819	BOLT M6X25	4
90	GB93	SPRING WASHER6	4
91	GB97.1	FLAT WASHER 6	4
92	GB6170	NUT M6	4
93	QJY4040-XW.5-06	OIL CYLINDER JOINT	1
94	GB6170	NUT M10	4
95	GB5783	BOLT M10X60	4
96	GB818	BOLT M6X20	4
97	GB889	NUT M24	2
98	SF-2	BUSH 3248	2
99	GB97.1	FLAT WASHER 18	4
100	EPL6-03	AIR TUBE JOINT	1
101		AIR TUBE	1
102	EPL6-02	AIR TUBE JOINT	1

Joel's GARAGE GEAR

www.joelsgaragegear.com.au